

®

**Rheometer Calibration Fixture
Instruction Manual
Model 280 & 286**

For more information, please contact us:

[ExpotechUSA](#)
[10700 Rockley Road](#)
[Houston, Texas 77099](#)
[USA](#)

[281-496-0900 \[voice\]](#)

[281-496-0400 \[fax\]](#)

E-mail: sales@expotechusa.com

Website: www.ExpotechUSA.com

TABLE OF CONTENTS

		Section	Page
1	Description	1	
2	Calibration Check Procedure Rheometer.....	3	
3	Spring Calibration Procedure Model 280 Rheometer	7	
4	Spring Calibration Procedure Model 286 Rheometer	11	
5	Parts List.....	15	
Table			
1	Calibration Weight vs Dial Reading	4	
Figure			
1	Typical Torsion Shaft Assembly	5	
2	Model 280 Set Up	6	
3	Model 286 Set Up	10	

SECTION 1 DESCRIPTION

The Rheometer Calibration Fixture is designed for calibration verification and calibration adjustment of the torsion spring in either the Model 280 or the Model 286 Rheometers. This instruction describes checking and adjusting the strength of the torsion spring such that a known torque will produce a known deflection, (dial reading). In this calibration known weights will be used to produce a known amount of angular rotation of the bob shaft, or dial reading. The Newton-cm of torque/degree of dial deflection is known as the K_1 factor. The K_1 (spring factor) is adjusted by adjusting the active length of the spring.

The Calibration Fixture may be used for:

- ✍ Calibration of a replacement spring when it is being installed.
- ✍ Verification of the calibration of the spring already in the instrument.
- ✍ Re-calibration of the spring already in the instrument.

Check the following parts of the Rheometer for runout or damage. If any of these parts are bent or otherwise damaged, repairs must be made before a successful calibration can be performed. Check the following:

- ✍ Bob Shaft and Bob for runout -- Straighten or replace.
Maximum total runout allowed is 0.005 in. (0.127 mm)
- ✍ Sleeve for runout -- Straighten or replace.
Maximum total runout allowed is 0.005 in. (0.127 mm)
- ✍ Deformed or damaged spring -- Replace.
- ✍ Mis-aligned dial "0" -- Readjust zero, (Refer to Sections 3-F7 or 4-F9)
- ✍ Torsion Shaft bearings defective --Replace

SECTION 2 CALIBRATION CHECK PROCEDURE

The Pulley Support, Pulley, and Calibration Spool are removed from the Calibration fixture and mounted on the Rheometer base and bob shaft to check its calibration. Dis-assembly of the Rheometer Sleeve, Bob, and Dust Shield is required.

If a Calibration of the spring is required, it will be necessary to remove the Torsion Shaft Assembly. A typical assembly is shown in Fig. 1. Dis-assembly, spring re-calibration, and re-assembly procedures are described in Section 3 for the Model 280 Rheometer and Section 4 for the Model 286 Rheometer.

A. Rheometer Set Up for Dead Weight Calibration

1. Unscrew and remove the Sleeve, Bob, and Dust Shield from the Rheometer.
2. Remove the Pulley Support [8] from the Fixture by removing the two 6-32 x 1/2 long screws holding the Pulley Support to the Calibration Stand Base.
3. Slide the Pulley Support over the center of the front edge of the Rheometer Base. Secure the pulley support by installing one of the screws just removed. This screw is installed from under the Rheometer Base into the hole in the Pulley Support closest to the pulley for the Model 280 Rheometer and away from the pulley for the Model 286 Rheometer.
4. Screw Calibration spool [5] onto bob shaft, threads down, until it tight. Wind two to three turns of thread around the drum clockwise as viewed from the top of the spool. (Refer to Fig. 2 for Model 280 and Fig. 3 for Model 286) Route the thread over the sheave, and allow it to hang. Make sure the thread does not lap over itself on the spool.
5. Adjust the height of the Rheometer head up or down such that the thread [6] coming off the spool and going to the pulley is horizontal.
6. Verify the hairline on the Rheometer jewel is aligned with "0" on the dial to an accuracy of +/- 1/2 division. If not the Rheometer should be zeroed. Refer to Section 3-F7 for the Model 280 Rheometer or Section 4-F9 for the Model 286 Rheometer.
7. Operate the Rheometer at 300 RPM and observe that there is less than +/- 1 division of dial movement. Excessive dial movement probably indicates dirty, corroded, or defective bob shaft bearings. This defect must be corrected before running the calibration check.
8. Attach weights to loop in thread. Make sure that thread does not roll over itself as it spools of and onto the drum.
9. Take readings as shown in the table 1.

B. Take readings as shown in the Table 1.

TABLE 1

WEIGHT	DIAL READING
25 GRAMS	103-104
50 GRAMS	204-206
75 GRAMS	309-312

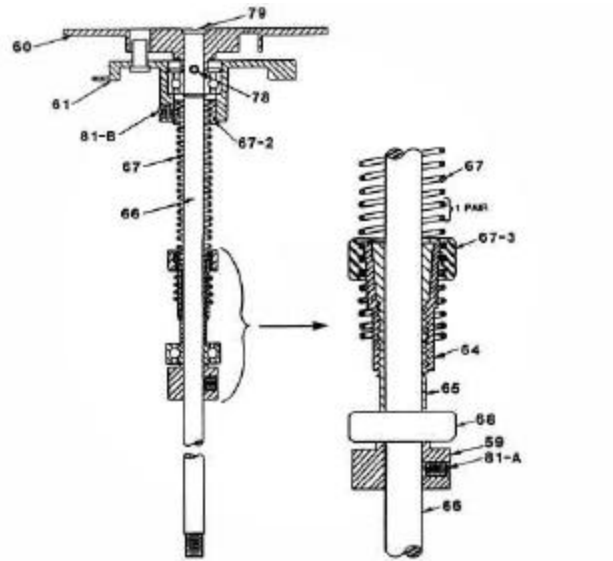

Fig. 1
Typical Torsion Shaft Assembly

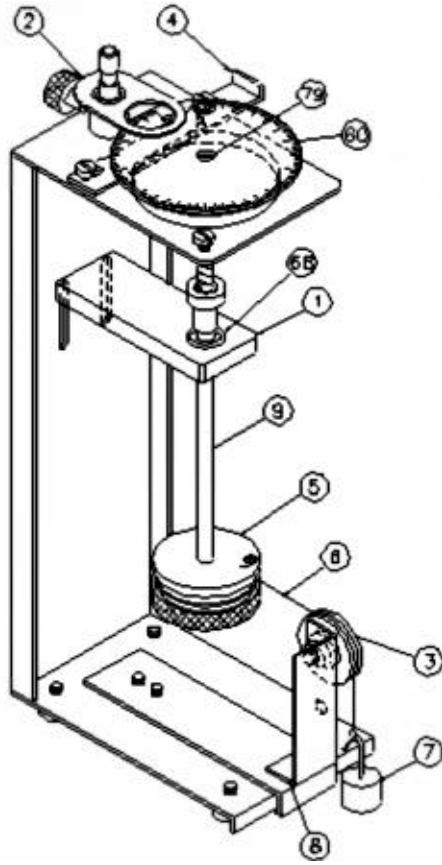

Fig. 2
Model 280 Set Up

SECTION 3 SPRING CALIBRATION PROCEDURE MODEL 280 RHEOMETER

This procedure requires the removal of the Torsion Shaft Assembly, shown in Fig.1, from the Rheometer, and mounting it in the Calibration Fixture.

A. Torsion Shaft Assembly Removal

1. Unscrew and remove the Sleeve, Bob, and Dust Shield from the Rheometer.
2. Place Rheometer speed shift lever in 300 RPM speed setting.
3. Remove flat head screw from center of Gel Knob.
4. Holding Gel Knob loosen hex set screw 1/4 turn using a hex key wrench and, then unscrew and remove Gel Knob.
5. Move Speed shift lever to the STIR position and pull shift arm, cam, and bearing off shift rod.
6. While holding rotor from turning, turn crank backward thereby unscrewing and removing it.
7. Remove four 6-32 x 1/4 long screws holding cover to frame, then pull cover up and off Rheometer.
8. Remove flat head screw [79] from top center of dial, then carefully lift dial straight up and remove.
9. Loosen two Zeroing screws that act as set screws against the flat on the Torsion Body, sufficiently to clear and allow removal of the torsion body.
10. Remove the large retainer ring on top of the Torsion Body.
11. Lift the torsion shaft assembly up and out of the Rheometer frame.
12. Re-assemble the Dial [60] onto the top of the Bob Shaft and secure it with screw [79].

B. Preliminary Spring Setting

A preliminary setting of the torsion spring should be made prior to mounting it in the fixture. Make this setting as follows:

1. Set the torsion spring assembly for approximately 9-1/4 to 9-1/2 pair turns by rotating the outer collet [67-3]. (Refer to Fig. 1) on spring [67] to the proper point.
2. Grasp the flats on lock collet [64] with needle nose pliers between lower spring coils. Holding the dial [60] turn it, torsion shaft, and collet [65] clockwise to loosen the thin notched portion of lock collet [64] from the spring [67]. and collet 67-3].
3. Slide the spring, with the outer collet [67-3] on it, over lock collet [64] until top of collet [67-3] is approximately even with top of lock bushing [65].

4. Grasp the flats on lock collet [64] with needle nose pliers between lower spring coils. Holding the dial [60] turn it, torsion shaft, and collet [65] counterclockwise to tighten the thin notched portion of lock collet [64] against spring [67]. and collet 67-3].

C. Mounting Torsion Shaft Assembly in the Calibration Fixture.

Re-assemble the Calibration Fixture and set it up for the Model 280 torsion shaft assembly. (Refer to Fig. 2).

1. Install the pulley [3] into the top hole of the Pulley Support Bracket.
2. Loosen the two screws holding the lower bearing support bar, [1] and position it at the top of the slots for the 280 Rheometer and re-tighten the screws.
3. Slide torsion shaft assembly into fixture from the top. Position torsion body hub into the hole in the top of the fixture and bearing [68] in the hole in the lower bearing support bar [1]. Rotate the torsion body to align the flat of the torsion body cross wise of the fixture. Secure the torsion assembly into the fixture by locking the lock bar [4] over the flat of the torsion body.
4. Remount the Dial [60] onto the top of the torsion shaft [66] with screw [79].
5. Position the hairline/magnifier [2] in the lower groove of its support. Rotate the hairline/magnifier [2] so the hairline aligns with the divisions on the dial and lock in place. Loosen set screw [81-B] to loosen collet [67-2] in the torsion body [61], then rotate the dial and bob shaft to align Zero with the hairline. Lock collet [67-2] in this position with set screw [81-B].
6. Screw Calibration spool [5] onto bob shaft, threads down, until it is tight. Wind two to three turns of thread around the drum clockwise as viewed from the top of the spool. (Refer to Fig. 2.) Route the thread over the sheave, and allow it to hang.

D. Taking the Readings

Hang the 25, 50 and 75 Gram weights each in turn on the loop in the end of the thread and note the dial readings obtained. (Refer to Table 1). If the dial readings are higher than shown in Table 1 - shorten the active part of the spring. If the dial readings are lower than shown in Table 1 - lengthen the active part of the spring.

E. Adjusting Torsion Spring:

1. Loosen hex set screw [81-B] holding upper spring collet [67-2] in torsion assembly body [61].
2. Loosen torsion spring adjusting collet as described in Section 3B-2. If the readings were too high, screw the threaded outer collet [67-3] up the spring pairs (1/4 turn will drop 3-5 dial units). If the readings were too low, screw the threaded outer collet [67-3] down the spring pairs (1/4 turn will change reading 3-5 dial units).
3. Align top of outer collet [67] slightly above top of widest section of lock bushing [65]. Tighten torsion spring adjusting collet as described in Section 3B-4.
4. Push upper spring collet [67-2] into torsion assembly body [61] and lock it with hex set screw [81-B] in a position so that dial zero aligns with the hairline.

5. Check calibration as described in Section 3D above. If still incorrect, repeat this section.

F. Re-assembly of the Torsion Shaft Assembly into the Rheometer.

1. Loosen and rotate the hairline/magnifier out of the way of removing the Torsion Shaft Assembly.
2. Unscrew the Calibration spool [5] and the thread [6] and remove them.
3. Remove screw [79], then remove dial [60].
4. Loosen and remove the lock bar [4] holding the Torsion Body, then lift the Torsion Body out of the Calibration Fixture.
5. Place the Torsion Shaft Assembly in the Rheometer with the flat on the Torsion Body toward the crank end of the rheometer, then install the retainer on top of the Torsion Body.
6. Assemble the dial [60] and secure with screw [79].
7. Temporally place the cover, with the hairline jewel in it, in place and observe the position of the hairline with relation to the "0" on the dial, then remove the cover and adjust the two zeroing screws against the flat on the torsion body to slightly rotate the torsion body as needed to align the "0" with the hairline. Recheck using the cover and repeat if necessary. Both zero adjust screws should be tight against the torsion body.
8. Place cover in place and install the four 6-32 x 1/4 long cover to frame screws.
9. Position shift arm in the STIR position, then install the shift arm, cam, and bearing onto the shift rod. Move shift arm to the 300 RPM position.
10. Turn crank forward while holding rotor from turning, screwing it into place and tighten.
11. Screw Gel Knob onto speed shaft as far as the hex set screw will allow. Use hex key wrench and holding Gel Knob tighten the hex set screw. Test the operation of the rheometer at 600 RPM and adjust the speed to 600 +/-3 RPM. If the rheometer is running too slow loosen the set screw 1/4 turn, then screw the Gel knob 1/4 turn further on. Re-tighten the set screw and retest. If the Rheometer is running too fast, loosen the Gel knob using the above procedure.
12. When the 600 RPM speed is properly set, install the flat head cover screw.
13. Assemble the Dust Shield and the Bob onto the Bob Shaft, then screw the Sleeve onto the Rotor.

NOTE: This spring calibration should be verified after assembly of unit in silicone calibration fluid.

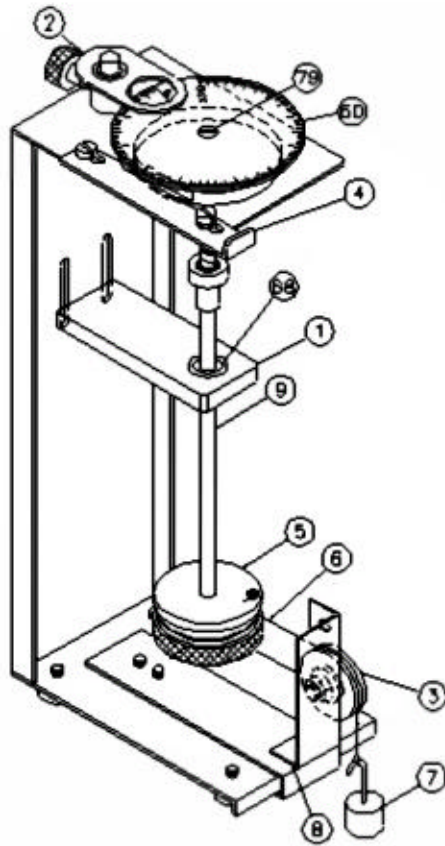

Fig. 3
Model 286 Set Up

SECTION 4 SPRING CALIBRATION PROCEDURE MODEL 286 RHEOMETER

This procedure requires the removal of the Torsion Shaft Assembly, shown in Fig.1, from the Rheometer, and mounting it in the Calibration Fixture.

A. Torsion Shaft Assembly Removal

1. Disconnect the Rheometer from the power source.
 2. Unscrew and remove the Sleeve, Bob, and Dust shield from the Rheometer.
 3. Use hex key wrenches loosen the set screws holding the power ON/OFF switch, the speed selector switch, and the knob for the variable speed control, then remove these three knobs.
 5. Remove the speed selector switch nut and the variable speed potentiometer nut holding these parts to the stainless steel cover. Use socket wrenches or nut drivers.
 6. Remove two 6-32 x 1/4 long cover to frame screws on the sides near the front of the Rheometer.
 7. Remove two 6-32 x 1/4 long cover to power supply bracket screws in the back of the Rheometer.
 8. Carefully lift the cover up and off Rheometer.
 9. Remove flat head screw [79] from top center of dial [60], then carefully lift dial straight up and remove.
 10. Remove printed circuit board by removing screws as follows:
 - ✍ Two 4-40 screws mounting the printed circuit board to the frame. These two screws go through the circuit board from the top. One is near each side of the board about 5 inches, (12.7 cm), from the square end.
 - ✍ One 1/4 inch long screw that attaches the power transistor to the frame on the right side as viewed from the curved front of the Rheometer frame.
 - One 3/8 inch long screw that attaches the voltage regulator to frame on the left side as viewed from the curved front of the Rheometer frame.
 11. If the heat sink sealer has the power transistor or the voltage regulator stuck to the frame, pry them loose.
 12. Lift the printed circuit board upward and allow it to swing out of the way hanging near the front left side of the instrument.
- Loosen two Zeroing screws that act as set screws against the flat on the Torsion Body, [item 6, Fig 1] (right hand side of frame) sufficiently to clear and allow

removal of the torsion body.

13. Remove the large retainer ring on top of the Torsion Body.
14. Lift the torsion shaft assembly up and out of the Rheometer frame.

B. Preliminary Spring Setting

A preliminary setting of the torsion spring should be made prior to mounting it in the fixture. Make this setting as follows:

1. Set the torsion spring assembly for approximately 9-1/4 to 9-1/2 active pair turns by rotating the outer collet [67-3] on spring [67] to the proper point. (Refer to Fig. 1)
2. Grasp the flats on lock collet [64] with needle nose pliers between lower spring coils. Holding the dial [60] turn it, torsion shaft, and collet [65] clockwise to loosen the thin notched portion of lock collet [64] from the spring [67]. and collet 67-3].
3. Slide the spring, with the outer collet [67-3] on it, over lock collet [64] until top of collet [67-3] is approximately even with top of lock bushing [65].
4. Grasp the flats on lock collet [64] with needle nose pliers between lower spring coils. Holding the dial [60] turn it, torsion shaft, and collet [65] counterclockwise to tighten the thin notched portion of lock collet [64] against spring [67]. and collet 67-3

C. Mounting Torsion Shaft Assembly in the Calibration Fixture.

Re-assemble the Calibration Fixture and set it up for the Model 286 torsion shaft assembly. (Refer to Fig. 3).

1. Install the pulley [3] into the bottom hole of the pulley holder bracket.
2. Loosen the two screws holding the lower bearing support bar, [1] and position it at the bottom of the slots and re-tighten the screws.
3. Slide torsion shaft assembly into fixture from the top. Position torsion body hub into the hole in the top of the fixture and bearing [68] in the hole in the lower bearing support bar [1]. Rotate the torsion body to align the flat of the torsion body parallel with the fixture. Secure the torsion assembly into the fixture by locking the lock bar [4] over the flat of the torsion body. For the Model 286 the bar [4] is parallel with the fixture with its notched side holding the torsion body. (Refer to Fig. 3).
4. Remount the Dial [60] onto the top of the torsion shaft [9] with screw [79].
5. Position the hairline/magnifier [2] in its upper groove of the support. Rotate the hairline/magnifier [2] so the hairline aligns with the divisions of the dial and lock in place. Loosen set screw [81-B] to loosen collet [67-2] in the torsion body [61], then rotate the dial and bob shaft to align 0 on dial with hairline/magnifier. Lock collet [67-2] in this position with set screw [81-B].
6. Screw Calibration spool [5] onto bob shaft, threads down, until it is tight. Wind two to three turns of thread around the drum clockwise as viewed from the top of the spool. (Refer to Fig. 3.) Route the thread over the sheave, and allow it to hang.

D. Taking the Readings

Hang the 25, 50 and 75 Gram weights each in turn on the loop in the end of the thread and note the dial readings obtained. (Refer to Table 1). If the dial readings are higher than shown in Table 1 - shorten the active part of the spring. If the dial readings are lower than shown in Table 1 - lengthen the active part of the spring.

E. Adjusting Torsion Spring:

1. Loosen hex set screw [81-B] holding upper spring collet [67-2] in torsion assembly body [61].
2. Loosen torsion spring adjusting collet as described in Section 3B-2. If the readings were too high, screw the threaded outer collet [67-3] up the spring pairs (1/4 turn will drop 3-5 dial units). If the readings were too low, screw the threaded outer collet [67-3] down the spring pairs (1/4 turn will change reading 3-5 dial units).
3. Align top of outer collet [67] slightly above top of widest section of lock bushing [65]. Tighten torsion spring adjusting collet as described in Section 3B-4.
4. Push upper spring collet [67-2] into torsion assembly body [61] and lock it with hex set screw [81-B] in a position so that dial zero aligns with the hairline.
5. Check calibration as described in Section 3D above. If still incorrect, repeat this section.

F. Re-assembly of the Torsion Shaft Assembly into the Rheometer.

1. Loosen and rotate the hairline/magnifier out of the way of removing the Torsion Shaft Assembly.
2. Unscrew the Calibration spool [5] and the thread [6] and remove them.
3. Remove screw [79], then remove dial [60].
4. Loosen and remove the lock bar [4] holding the Torsion Body, then lift the Torsion Body out of the Calibration Fixture.
5. Place the Torsion Shaft Assembly in the Rheometer with the flat on the Torsion Body toward the right side of the Rheometer, then install the retainer on top of the Torsion Body.
6. Reposition the printed circuit board on the top of the Rheometer. Be especially careful to make sure the following are not damaged.

✍ Make sure the encoder disc on the motor flywheel fits into the groove of the photo transistor sensor assembly. **DO NOT BEND THIS DISC.**

✍ Make sure the heat sink surfaces on the power transistor and the voltage regulator and the corresponding surfaces of the frame have been cleaned and new heat sink compound has been applied.

✍ Make sure all holes in the circuit board are in line and nothing is binding the circuit board as it is assembled into place.

✍ Make sure the two top mounting holes are in line and the holes for the

power transistor and voltage regulator are in line.

7. Mount the circuit board by installing the following screws:
 - ✍ Two screws from the top of the PC board into the frame
 - ✍ One screw holding the power transistor to the frame
 - ✍ One screw holding the voltage regulator to the frame
8. Assemble the dial [60] and secure with screw [79].
9. Temporally place the cover, with the hairline jewel in it, in place and observe the position of the hairline with relation to the "0" on the dial.

Remove the cover and adjust the two zeroing screws on the right side of the frame and against the flat on the Torsion Body. Loosen one and tighten the other to slightly rotate the torsion body as needed to align the "0" with the hairline.

Recheck using the cover and repeat if necessary. Both zero adjust screws should be tight against the torsion body when adjustment is complete.
10. Install Cover by installing the following fasteners:
 - ✍ Two 6-32 x 1/4 long cover to frame screws
 - ✍ Two 6-32 x 1/4 long cover to power supply bracket screws.
 - ✍ Nut cover to speed selector switch
 - ✍ Nut cover to variable speed potentiometer. (Use socket wrenches or nut drivers).
11. Install switches. Use hex key wrenches to tighten their set screws. Make sure these set screws are seated on the flats on the switch shafts.
 - ✍ Power ON/OFF switch
 - ✍ Speed selector switch knob
 - ✍ Variable speed control
12. Assemble the Dust Shield and the Bob onto the Bob Shaft, then screw the Sleeve onto the Rotor.
13. Connect the Model 286 Rheometer to the power source and test its performance.

NOTE: This spring calibration should be verified after assembly of Rheometer by the silicone oil calibration method. Refer to Model 286 Instructions.

SECTION 5 PARTS LIST

A. Calibration Stand Parts List

Part No.	Description
28635	Weights, 25 grams & 50 grams
31509	Thread
E1007	Instructions
L4903	Bearing, bob shaft

B. Optional Calibration Fluids

PART NO.	DESCRIPTION
28696	Calibration Fluid 10 cP
28691	Calibration Fluid 20 cP
28692	Calibration Fluid 50 cP
28693	Calibration Fluid 100 cP
28694	Calibration Fluid 200 cP
28695	Calibration Fluid 500 cP

For more information, please contact us:

ExpotechUSA

10700 Rockley Road
Houston, Texas 77099
USA

281-496-0900 [voice]

281-496-0400 [fax]

E-mail: sales@expotechusa.com

Website: www.ExpotechUSA.com