

**Model 21150 Differential Sticking Tester
Instruction Manual**

®

For more information, please contact us:

[ExpotechUSA](#)
[10700 Rockley Road](#)
[Houston, Texas 77099](#)
[USA](#)

[281-496-0900 \[voice\]](#)

[281-496-0400 \[fax\]](#)

E-mail: sales@expotechusa.com

Website: www.ExpotechUSA.com

TABLE OF CONTENTS

1	General Information	1
2	Safety Considerations	3
3	Timed Filtration Test Procedure	7
4	Fixed Cake Thickness Test Procedure	13
5	Calculations and Theory of Measurements	15
6	Cleaning and Maintenance	23
7	Parts List	27

FIGURES

1	Cell Assembly	5
2	Cell Section	6
3	Closing and Opening Cell (Opening shown)	9
4	Sticking The Torque Plate	10
5	Measuring Sticking	10
6	Work Sheet	20
7	Exploded View Pressure Regulator	21
8	Exploded View Differential Sticking Tester	26

SECTION 1 GENERAL INFORMATION

The Differential Sticking Tester Apparatus was designed to determine how likely a given drilling fluid will be to produce a "stuck pipe" situation and how effective a given drilling fluid treatment or application of spotting fluid in any given drilling fluid would be in reducing this tendency. This measurement is called the "Stuck Tendency Coefficient". It takes into account both the stickiness and the cake building capability of the drilling fluid. The "Stuck Tendency Coefficient" is determined by the Timed Filtrate Test.

The use of the optional yoke attachment along with the radius'd torque plate allows a measurement called "Bulk Sticking Coefficient" to be obtained. By measuring the area of caking using a controlled cake thickness during the test, the "Bulk Sticking Coefficient" is obtained. The Bulk Sticking Coefficient is determined by the Fixed Cake Thickness Test.

The unit can be pressurized by the CO₂ regulator assembly or from any nitrogen source. If Nitrogen is to be used, the Differential Sticking Tester must be fitted with a suitable Nitrogen regulator, gauges, relief valve, hose and fittings. The tests use 477.5 psi (3292 kph) differential pressure applied to a stainless steel vessel of approximately 200 ml capacity. The measurement can be made using either the flat-faced torque plate or the 12-1/2" (31.75 cm) spherical radius¹ plate which approximates pipe in casing or collars in borehole contact geometry. (Both are provided.) In the event of a "sticky" sample that tends to adhere more to the torque plate than to the filter paper, stainless steel micro-corrugation disks are provided, along with extra-strength paper (within 2% of standard paper filtration speed) to ensure success of the test.

SECTION 2 SAFETY CONSIDERATIONS

Safe operation of the Differential Sticking Tester requires that the operator understand and practice the correct assembly and operation of the equipment. Improper assembly, operation, or the use of defective parts poses the possibility of cell leakage or failure which could result in serious injury and damage.

Following is a list of suggestions that should be observed to assure safe operation and maintenance of the Differential Sticking Tester.

A. Safe Pressurization

1. Always use either Carbon Dioxide or Nitrogen. Never connect the Differential Sticking Tester to Compressed Air, Oxygen or other non-recommended gas. If Nitrogen is used it must be supplied in an approved Nitrogen gas cylinder or the nitrogen supply system must be built into the laboratory. Nitrogen Cylinders must be secured to meet safety standards. Carbon Dioxide is normally supplied in small cartridges which contain about 900 psi (6206 kPa) pressure. They are primarily used for field operations. Do not allow these cartridges to be heated or exposed to fire. They can explode if overheated.
2. Maintain pressure regulators in good condition. Never use oil on pressure regulators. Leaking pressurization systems should be repaired or replaced. Gauges, fittings and hoses should be kept in good condition and leaks should be found and corrected. If Nitrogen is being used, periodically test the safety relief valve to verify they will relieve if excessive pressure should occur. Never plug or bypass the safety valve.
3. Before pressurizing the Differential Sticking Tester always check to be sure the regulator tee screw is backed out until free turning thereby putting the regulator in the closed position. Insert and puncture the CO₂ cartridge or open the nitrogen gas supply valve, then adjust the regulator. Do not attempt to pressurize higher than the equipment is rated. When de-pressurizing, shut off the supply pressure, bleed the system of pressure, then back out the regulator Tee screw.

B. Safe Test Cell Maintenance

The Differential Sticking Tester Cell Assembly constitutes a PRESSURE VESSEL. The Safety Precautions listed should be followed to assure safe operation.

1. Cell material should be compatible with the test sample.
2. Cells that show signs of stress cracking, severe pitting, or have damaged threads must not be used.

C. Safe Operation

The Differential Sticking Tester is a relatively small and light weight instrument. Observe the following cautions in its operation to prevent injury and damage due to the instrument slipping on the work bench or accidentally being knocked off the bench.

1. Before attempting to tighten Cell Cap onto Cell Body, Refer to Fig. 3, make sure Bolt [26], Fig. 2 is installed and tightened. This will insure the Cell does not slip off the Stage.

2. Make sure the instrument is setting flat on the bench and not close to the edge and that the groove in the lever is fit under the top leg support before pressing down and holding the lever to stick the torque plate. Refer to Fig. 4. Use caution that the lever does not slip and cause an accident.

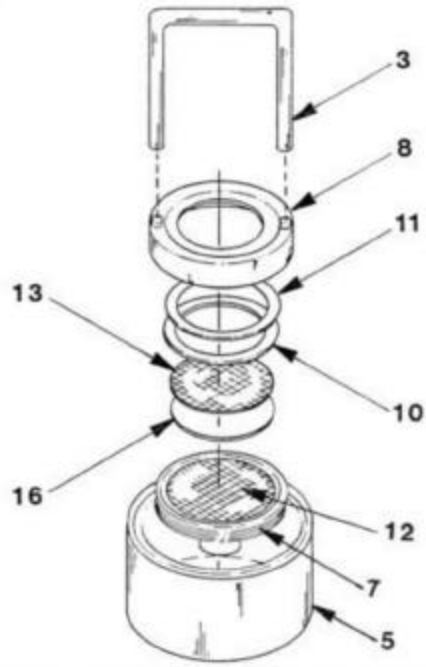

Fig. 1 - CELL ASSEMBLY
(Refer to Section 7 for Identification of Numbered Items)

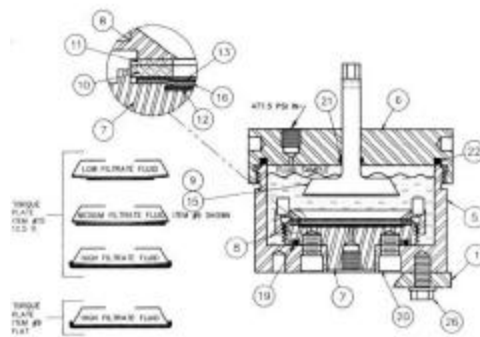

Fig. 2 - CELL SECTION
(Refer to Section 7 for Identification of Numbered Items)

SECTION 3 TIMED FILTRATION STICKING TEST PROCEDURE (Numbers in [] refer to Fig. 1 thru 5)

The general procedure for assembling and operating the instrument is basically the same whether the test described in Section 3 or Section 4 is being run. Ensure that the apparatus is clean. Refer to Section 6.

The timed filtration sticking test uses a predetermined sticking time to determine the sticking coefficient. In this test the stuck tendency coefficient K_{st} is determined. If the flat plate [9] is used $R = 1$ with edge effects considered. Refer to Step B-3 below. If the radius'd plate [15] is used, the stuck surface may be less than $R = 1$, $R = 1$, or $R = 1$ with edge effects depending on the cake building characteristics of the drilling fluid. Refer to Step B - 3 below. In this test the bulk sticking coefficient K_{sc} is determined.

A. Cell Assembly

1. Place a sheet of heavy-duty filter paper, Part #N8805 [16], locking mesh (if used) [13]), rubber gasket [10], and plastic ring [11] inside the cell.

NOTE: The locking mesh will lock the drilling fluid cake to the paper so that it cannot invalidate the test results by sticking to the torque plate face and breaking loose from the filter paper.
2. Holding the gaskets centered, screw the hold-down retainer ring [8] over the gaskets. Use the ring wrench [3], and tighten securely.
3. Insert the threaded end of one valve stem [17] into the bottom center hole of the cell and screw in as far as possible hand tight. .
4. Fill the cell to the scribe line with the drilling fluid sample to be tested. This is 1/4 in. (6.3 mm) from the top.
5. Set the cell on its stand [1], mating two of its holes into the stand tips. If the valve stem in the lid is in line with the stand columns, this will interfere with the lever [4]. Rotate the cell 90°.
6. Select either the flat bottom torque plate [9], or the radius'd torque plate [15]. Refer to Section 5-B "PLATE SELECTION" for effects of each type of torque plate. Insert the stem of torque plate [9] or [15] through the lid as far as possible with the polished surface facing down from the inside of the lid. Be careful not to cut the "O" Ring [21].
7. Assemble the cell cap [6] and torque plate onto the cell, making sure the "O" ring [22] is properly seated in the lid.
8. Secure the cell to the stand using screws [26]. This will facilitate tightening of the cell cap and torque wrench usage by one person.
9. Tighten the cell cap, Refer to Fig. 3.
10. Insert the second valve stem [17] into cell cap. Close the valve hand-tight.
11. Set the CO₂ assembly [2] over the top end of the top valve stem [17] and insert the locking pin [27].
12. Close the bleed valve on the CO₂ assembly.

13. Turn the regulator handle counterclockwise until the diaphragm pressure is relieved.
14. Insert the CO₂ cartridge [25] into the knurled CO₂ holder. Tighten the holder onto the head, puncturing the cartridge.
15. Place graduated cylinder [29] under the cell and turn the lower valve stem valve 1/4 turn counterclockwise from hand-tight.
16. Adjust the regulator to 477.5 PSI (3292 kPa).

B. Running The Sticking Test

1. Verify the torque plate stem is up as far as possible by turning and pulling upward at the same time.

NOTE: If the torque plate placement "yoke" option [14] is used, refer to Section 4.

2. Open the top valve-stem by turning it counterclockwise 1/2 to 3/4 turn using a small adjustable wrench, then record the time as the start of the test.
3. Allow the drilling fluid to filter for 10 minutes (or to the desired cake thickness if the "yoke" option is being used), or until the desired filtrate volume is collected.

NOTE: If the yoke option is being used, step 4 is not required. The torque plate will stick when the cake builds to it.

4. Catch the groove in the lever (4) under the column top cross support and press the plate down. Refer to Fig. 4. Continue to hold the torque plate all the way down against the screen until pressures equalize sufficiently to allow the plate to stick. This is usually about two minutes and will require 50 to 80 pounds (23 to 36 kg) of force on the end of the lever.
5. Record the filtrate volume at this time.
6. Allow the plate to stick for 10 minutes.
7. Assemble the socket [30] on the torque wrench [24]. Place the torque wrench and socket on the hex top of the torque plate stem. Position the lever [4] wedged between the columns above the cell platform to be used as a backup. Refer to Fig. 5.

CAUTION

SHOULD THE FILTER PAPER TEAR WHEN THE TORQUE PLATE IS ROTATED, CELL PRESSURE WILL BE EXHAUSTED OUT THE FILTRATE VALVE. A STANDARD HPHT BACK PRESSURE RECEIVER CAN BE SUBSTITUTED FOR THE GRADUATE WHILE THE TORQUE READINGS ARE TAKEN, OR A LENGTH OF RUBBER OR TYGON TUBING CAN BE ATTACHED TO THE VALVE STEM WITH THE OTHER END RESTRAINED IN A CONTAINER

8. Measure the torque by rotating the torque plate in either direction with the torque wrench and observing its dial.
9. Repeat the torque measurement three to six times, allowing 30 seconds between checks.

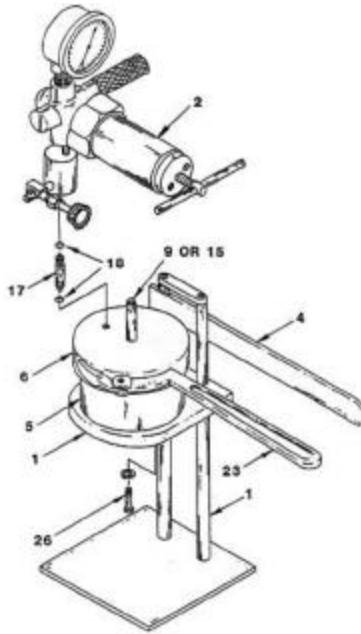

**Fig. 3 - CLOSING AND OPENING CELL
(OPENING SHOWN)**
(Refer to Section 7 for Identification of Numbered Items)

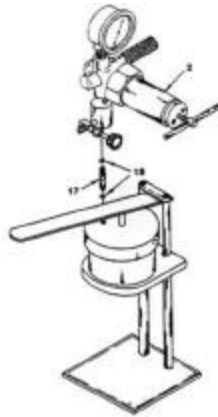

Fig. 4 - STICKING THE TORQUE PLATE



Fig. 5 – MEASURIN STICKING
(Refer to Section 7 for Identification of Numbered Items)

10. Record each of these readings, then calculate the average torque reading. Record the plate sticking time.
11. Turn the regulator handle counterclockwise until the diaphragm pressure is not felt. Then open the bleed-off valve.

C. Dis-assembly and Cleaning

1. Remove the empty CO₂ cartridge (if spent.)
2. Remove the torque wrench and socket.
3. Pull pin [26] and remove the CO₂ assembly [2].
4. Remove the top valve stem [17].
5. If yoke assembly was used, remove the locking pins, then remove the yoke.
6. Loosen the cell cap [6], then unscrew and remove it. If the torque plate remains stationary while loosening and unscrewing the cell cap, carefully push it through the lid by its stem. Refer to Fig. 3.
7. Tip the Sticking Tester with the cell attached to empty the sample.
8. Gently wash the sample from the edge of the torque plate.
9. TWIST the torque plate off the cake. Note the diameter of the depression from the torque plate if this is less than 2 inches or if any cake is adhering to the edge of the torque plate, estimate the edge height from the filter paper.

NOTE: If the cake is stuck to the torque plate rather than to the filter paper, the test is invalid. Repeat the test using the locking mesh in Step A-1. above.

10. If not already removed in Step 6 above, remove the torque plate from the cell cap, being careful not to scratch the polished surface.
11. Using the special wrench [3], unscrew the hold down ring, then remove the slip ring, and gasket. Remove the lock mesh, filter paper, and filter cake together. Examine the cake as desired.
12. Remove screw [26] then remove the Cell from the stage.
13. Clean all parts thoroughly. Polish surfaces whenever any corrosion is noted.
14. Lubricate threads, and examine all "O" rings and replace as needed. Lubricate all "O" rings with Lubriseal or a similar lubricant.

SECTION 4 FIXED CAKE THICKNESS TEST

A modification of the timed filtration sticking test may be used to obtain a predetermined cake thickness test. In this test the bulk sticking coefficient K_{sc} is determined. If the flat plate [9] is used $R = 1$ with no edge effects. Refer to Step B-3 below. If the radius'd plate [15] is used, enough time after sticking of the plate must be allowed for the cake to build before the $R = 1$ condition exists. Refer to Step B - 4 below. To run this test an accessory "yoke" mechanism (Part 21154) must be used. This "yoke" attaches onto the cell cap and is used to set the torque plate at a given distance from the filter surface. This distance is the desired cake thickness usually $2/32"$ (1.6 mm).

A. Cell Assembly

1. Assemble the Cell as described in Section 3, Steps 1 through 10.
2. Install the yoke assembly onto the cell cap by fitting the two set screws on the sides of the yoke into the holes in the cell cap. Tighten these screws hand tight.
3. Connect the stem of the torque plate to the Tee screw of the yoke assembly by fitting the stem of the tee screw over the torque plate stem then aligning the lock pin hole with the groove in the torque plate stem and inserting the lock pin.
4. Turn the Tee screw down until the torque plate face touches paper (or locking mesh), then turn it back the thickness the cake desired (such as $2/32"$ (1.6 mm)). One turn equals $1/32"$ (0.8 mm), therefore turn it the number of turns required to set the cake thickness desired, one turn for $1/32"$ (0.8 mm), 1-1/2 turns for $3/64"$ (1.2 mm), 2 turns for $2/32"$ (1.6 mm) etc.
5. Complete the Cell Assembly Section 3 Steps 11 through 16.

B. Running The Sticking Test

1. Open the top valve-stem and record the time as the start of the test.
2. Allow the cell to filter until the plate is stuck. This can be recognized by a "click" heard when the lock pin is bound by the plate's sticking. Check the lock pin for binding. The time required will vary according to the cake building properties of the drilling fluid sample. It will be helpful to have a history of similar samples to estimate about when the predetermined cake thickness will occur.
3. If the flat torque plate is being used, take the torque readings as described in Section 3-B Steps 7 through 11 immediately after the plate is stuck. This gives a condition such that $R = 1$ with no edge effects.
4. If the radius'd torque plate is being used, the time for additional cake to build sufficient to achieve $R = 1$ with no edge effects will have to be determined by trial and error. The cake must build up to, but not around the edge.
5. Wait the time determined in Step 4 above, then take the torque readings as described in Section 3-B Steps 7 through 11.
6. If preferred, a finite time, 10 minutes for example, can be used and the stuck cake area on the radius'd torque plate can be measured. The domed area diameter measured when R is less than 1", or the average edge height measured when $R = 1$ ", and edge effects will be used in the calculations. (Refer to Section 3-C Step 9 Disassembly and Cleaning)

SECTION 5 CALCULATIONS AND THEORY OF MEASUREMENT

A. **Stuck Tendency Coefficient**

Using the standard test described in Section 3 "Standard Test Procedure" and the 12.5" (31.75 cm) radius'd plate and 477.5 psi (3292 kPa), the average of 6 "break" readings taken within 30 seconds of one another divided by 1000 is known as the **STUCK TENDENCY COEFFICIENT** (K_{st}) of a drilling fluid. This coefficient takes into account both the bulk sticking coefficient and the cake-building character of the sample (Refer to Fig. 2).

The physical basis for the Stuck Tendency Coefficient is that it takes into account both the static coefficient of friction of the cake (the bulk sticking coefficient) per unit area of cake and also the amount of caking that would occur to stick the pipe in the hole. A low caking drilling fluid will not build up as much around the collars as a high caking drilling fluid. There is a higher bond area for a higher caking drilling fluid. A very sticky drilling fluid which builds very little cake is safer downhole than a high cake building drilling fluid with high permeability that sticks a much greater area at even a factor of one half the bulk coefficient, resulting in a higher Stuck Tendency Coefficient.

B. **Selection of Plates--Radius'd or Flat**

Generally for direct K_{st} readings, use the radius'd plate, since only in the case of high caking drilling fluids will the flat plate provide comparative readings to the radius'd plate. The flat plate does not take into account collar-to-well bore or drill stem-to-casing geometry for the caking area component of the K_{st} coefficient. The difference between the flat plate and radius'd plate in the K_{sc} measurements is that the radius'd plate requires measuring stuck area dome diameters less than 2" (5.08 cm), as well as getting average edge height readings, as is done with both. The same is true when using the yoke accessory for finding K_{sc} of a given cake thickness. The thickness of the cake and the type of plate used determine the parameters for calculation of K_{st} and K_{sc} .

C. **Conditions for type of torque plate and drilling fluid cake types are listed below:**

1. Radius'd Plate 12.5 inch (31.75 cm) Spherical Radius
 - Sample Contact less than 1 inch (2.54 cm) radius
 - Sample contact equal to 1 inch (2.54 cm) radius, edge effects ignored
 - Sample contact equal to 1 inch (2.54 cm) radius, edge effects considered
2. Flat Plate
 - Sample contact always equal to 1 inch (2.54 cm), edge effects considered

NOTE: The flat plate will always have a 1 inch (2.54 cm), stuck radius and will always have at least some edge effects.

In taking into account the edge effects on either plate, the assumption is made that the full pressure of 477.5 psi (3292 kPa) is not achieved on the full height (h) of the cake, but on 2/3 of (h). This is assumed because the cake is permeable and the pressure drop is a gradient throughout the thickness of the cake (h) on the vertical edge.

D. Derivation-Bulk Sticking Coefficient

The bulk sticking coefficient (K_{sc}) is the ratio of the *force necessary to initiate sliding* (F_s) of the plate to *the normal force* (F_n) on the plate.

Let T_u = average of reading from torque wrench (inch-pounds)

- R = radius of plate (inches)
- h = height above flat surface of cake around edge of plate (inches)
- P = cell pressure, (psi) differential (inlet to outlet)
- r = variable radius
- dr = incremental radius
- t_y = shear on incremental area
- F_s = sliding force
- F_n = normal force on plate
- K_{sc} = bulk sticking coefficient
- K_{st} = stuck tendency coefficient
- A = stuck area, radius'd plate
- A_e = stuck area, edge

1. **The Sliding Force (F_s)**

- a. Calculation for use when neglecting edge effects is derived from the measured torque T_u as follows:

$$T_u = \int_0^R 2\pi r t_y dr$$

$$= \int_0^R 2\pi r (\mu P) dr$$

$$= 2\pi \mu P \int_0^R r dr$$

$$= \pi \mu P R^2$$

$$T_u = \pi \mu P R^2$$

$$F_s = \pi \mu P R^2$$

NOTE: $R = 1$ assumes cake sticking up to, but not around, the edge of the plate.

b. Calculation for use when taking into account the edge effects is derived from the measured torque as follows:

$$T_u = \text{click here to view equation.} \quad 8$$

$$= \text{click here to view equation.} \quad 9$$

$$\frac{3}{2} T_u = \text{click here to view equation.} \quad 10$$

$$= \text{click here to view equation.} \quad 11$$

$$= \text{click here to view equation.} \quad 12$$

$R = 1$ inch, and assuming that the 477.5 psi (3292 kPa) on the average is achieved only $\frac{2}{3}$ the distance of the cake deposition up the edge:

$$F_s = \text{click here to view equation.} \quad 13$$

2. The normal force (F_n)

The differential or normal force (F_n) on the plate is derived by multiplying the area by the differential pressure:

$$F_n = \text{click here to view equation.} \quad 14$$

Considering edge effects:

$$F_n = \text{click here to view equation.} \quad 15$$

With edge effects $R = 1$ inch

$$= \text{click here to view equation.} \quad 16$$

Then, assuming the recommended pressure of 477.5 psi (3292 kPa)

$$F_n = \text{click here to view equation.} \quad 17$$

$$= \text{click here to view equation.} \quad 18$$

E. The Bulk Sticking Coefficient (K_{sc})

The bulk sticking coefficient K_{sc} is the ratio of the sliding force to the normal force:

$$K_{sc} = \text{click here to view equation.} \quad 19$$

1. Ignoring edge effects:

- Install Equation Editor and double -
= click here to view equation. 20
Install Equation Editor and double -
= click here to view equation. 21

For a standard pressure of 477.5 psi (3292 kPa):

- Install Equation Editor and double -
 K_{sc} = click here to view equation. 22

(And for R = 1 inch):

- Install Equation Editor and double -
 K_{sc} = click here to view equation. 23

2. Taking into account edge effects:

- Install Equation Editor and double -
 K_{sc} = click here to view equation. 24
Install Equation Editor and double -
= click here to view equation. 25

For a standard pressure of 477.5 psi (3292 kPa) and R = 1 inch

- Install Equation Editor and double -
 K_{sc} = click here to view equation. 26
Install Equation Editor and double -
 K_{sc} = click here to view equation. 27

The Stuck Tendency Coefficient (K_{st}) is:

- Install Equation Editor and double -
 K_{st} = click here to view equation. 28

NOTE: K_{st} is not valid for the flat plate because the stuck area is either 0 or 3.14 in² (R = 1) and not a variable.

F. Example 1.

The drilling fluid sample is mixed and loaded into the cell, then pressurized at 477.5 psi (3292 kPa) for 10 minutes. The torque plate is seated using the lever and holding for two minutes. Eight minutes are allowed to pass, then breaking torque is measured in four breaks, 30 seconds apart, at 36 inch pounds (41.47 kg-cm), 39 inch pounds (44.93 kg-cm), 40 inch pounds (46.08 kg-cm), and 41 inch-pounds (47.23 kg-cm). The drilling fluid sample has an average .039 Stuck Tendency Coefficient. The pressure is removed and the cell is opened carefully, leaving the torque plate set in the cake. The cake-torque plate assembly is washed and the torque plate is turned (not lifted) loose. The diameter of the imprint of the torque plate impression (smooth domed area) is measured. The diameter is 1.57 inches (3.95 cm) giving a radius of 0.785 inches (1.98 cm).

Therefore, (using inch dimension) So $R = .785$; so $K_{sc} =$ Install Equation Editor and double-click here to view equation. 29

Example 2

The "yoke" is attached and it is found that 1/2 hour is required for cake buildup to occur to full face at 3/64 in (2.0 mm) thickness. Knowing this, the extra sample is tested and torque is measured at 85 inch-pounds, giving a .085 K_{sc} of 3/64" (2.0 mm) thickness.

WORK SHEET

1. Using Radius'd Plate and inch dimensions

Install Equation Editor and double -
click here to view equation. 30
 $K_{st} =$
Install Equation Editor and double -
click here to view equation. 31
 $=$

for a standard pressure of 477.5 (3292 kPa):

Install Equation Editor and double -
click here to view equation. 32
 $K_{st} =$
Install Equation Editor and double -
click here to view equation. 33
 $=$

2. Using radius'd plate and 477.5 psi (3292 kPa) and inch dimensions:

a. For cake with less than 1 inch stuck radius:

Install Equation Editor and double -
click here to view equation. 34
 $K_{sc} =$
Install Equation Editor and double -
click here to view equation. 35
 $=$

b. Using either radius'd or flat plate and 477.5 psi (3292 kPa) and inch dimensions:

For cake with 1" radius, edge effects considered and a pressure 477.5 psi (3292 kPa):

Install Equation Editor and double -
click here to view equation. 36
 $K_{sc} =$
Install Equation Editor and double -
click here to view equation. 37
 $=$

3. For tests using the yoke attachment, the cake thickness before sticking should be recorded, and the data in 1, 2a, and 2b above apply.

1. Using Radius" d Plate and inch dimensions

$$K_{st} = (\text{Average Torque Wrench Reading})(\text{Pressure}) \times (.001) / (477.5)$$

$$= (() \times (.001)) / (477.5) =$$

for a standard pressure of 477.5 (3292 kPa):

$$K_{st} = (\text{Average Torque Wrench Reading}) \times .001$$

$$= () \times (.001) =$$

2. Using radius" d plate and 477.5 psi (3292 kPa) and inch dimensions:

- a. For cake with less than 1 inch stuck radius:

$$K_{sc} = (() \times (.001)) / (\text{Measure Stuck Cake Radius})^3$$

$$= (() \times (.001)) / ()^3$$

- b. Using either radius" d or flat plate and 477.5 psi (3292 kPa) and inch dimensions:

For cake with 1" radius, edge effects considered and a pressure 477.5 psi (3292 kPa):

$$K_{sc} = ((\text{Average Torque Wrench Reading}) \times (.001)) / (1 + 1.33(\text{Cake Height on Edges}) \text{ Inches})$$

$$= (() \times (.001)) / (1 + 1.33()) =$$

3. For tests using the yoke attachment, the cake thickness before sticking should be recorded, and the data in 1, 2a, and 2b above apply.

Fig. 6
Sample Work Sheet

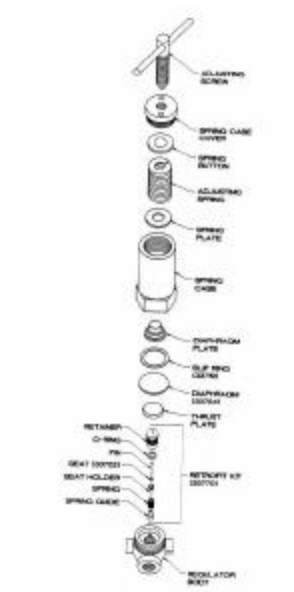

Fig. 7
Exploded View Pressure Regulator

SECTION 6 CLEANING AND MAINTENANCE

Standard laboratory procedures apply to the cleaning of the Differential Sticking Tester. After each test, the cell should be dis-assembled completely and thoroughly cleaned and dried of all sample and other contaminants, with particular attention to "O" rings and "O" ring grooves.

Wash and dry the support screen and locking mesh disc.

Wipe spilled sample or other debris from the stand. Some sample materials may damage the finish of these parts if allowed to remain on them for a long period of time.

A. Cell Maintenance

1. Cell Corrosion

CAUTION

CORROSION PITTING AND CRACKING CAN CAUSE RUPTURE OF CELLS

Sample fluids used in this instrument can, at times, cause corrosion of the test cell and cell cap. The standard cell is made of Type 303 Stainless Steel. Cells are available in other materials for use where the stainless steel is not suitable because of corrosion problems. An inspection of the inside of the cell for evidence of corrosion should be made periodically. Light corrosion may be removed using 320 or finer wet or dry sand paper. Deeper corrosion pitting may be removed by sand blasting the area of the corrosion. More severe corrosion will require re-machining or re-surfacing the inside of the cell. If severe corrosion is evident, the cell should be replaced.

2. "O" Rings

Inspect all "O" rings as they are being cleaned for cuts or nicks. Replace any damaged "O" rings. Lubricate "O" rings before they are installed. For most applications, laboratory stop cock grease is satisfactory; however, since some "O" rings come into contact with the sample, care should be taken that the lubricant is compatible with the sample.

3. Valve Stems

A metal to metal pressure tight seal is made between the valve stem and its seat. Leaks can occur if either the valve stem or seat is damaged. The cone point of the valve stem may be inspected for damage by removing the valve stem from the cap or body. If the point is damaged, replace the valve stem. If the point appears to be in good condition, the seat in the cell or cap may be rough. A 5/16 inch drill bit can be used to resurface the seat, or a special tool (38717) may be used. Valve stems should be inspected for possible plugging of the passages by dried sample. A small drill or wire can be used to insure that both the cross bore and the main passage openings are clear.

B. Safety Considerations of Pressure Systems

Safe operation of pressurized equipment requires the pressurizing system be properly maintained. Specific procedures for the safe use of pressure regulators are listed below:

1. Never subject a regulator to inlet pressure greater than its rated inlet pressure, as shown on the regulator body.
2. Never use the regulator for gases other than those for which it is intended.
3. All connections to the regulator must be clean. Remove oil, grease, or other contaminants from external surfaces of the regulator and metal connecting parts.
4. Before attaching regulator to the cylinder, remove any dirt or foreign matter that may be in the cylinder valve outlet by wiping with a clean, lint free cloth.

CAUTION

THE VALVE ON THE CYLINDER MAY BE OPENED MOMENTARILY TO BLOW THE OUTLET CLEAN. MAKE SURE THE CYLINDER OPENING IS POINTED AWAY.

5. Never pressurize a regulator that has loose or damaged parts or is in questionable condition. Never loosen or attempt to tighten a connection or a part until the gas pressure has been relieved. Under pressure, gas can dangerously propel a loose part.
6. Before transporting gas cylinders, remove regulator and recap cylinder.
7. Keep cylinder hand wheel or wrench on open cylinder valve at all times, for prompt emergency cutoff.
8. Check regulator and all connections for leaks after installation, periodically thereafter, and after any service in which parts or connections were disconnected and reconnected, using a soap solution around fittings to find small leaks. Bubbles will indicate a leak.

C Regulator Troubleshooting

The primary causes of regulator problems are leaking fittings or faulty pins and seats. Rarely does a diaphragm rupture. If a regulator will not hold pressure:

1. Check for leakage around fittings.

Pressure the system and look for escaping gas in the form of bubbles. This can be done by applying soap suds to the possible leak area, or the regulator assembly, except for the gauge, may be submerged in water. Repair by dis-assembling and applying tape thread sealant.

2. A faulty pin and seat will usually be evidenced by leakage through the regulator to the down stream side as opposed to external leakage. Check for bubbles coming out of the regulator when it is supposed to be shut off.
3. Dirt or sample contamination in regulator

Some of the more common symptoms of a possibly faulty regulator are listed below:

1. Gas leaking at the regulator outlet when the adjusting screw is completely released
2. With no flow through the system (downstream valves closed and adjusting screw in), working pressure increasing steadily above set pressure.
3. Gas leakage from spring case (adjusting screw end of regulator)
4. Gas leakage from any point
5. Excessive drop in working pressure with regulator flow open
6. Gas leakage from relief valve

D. Regulator Repair

If it is determined a regulator is faulty, it must be disassembled, cleaned, and repaired as determined from the above symptoms.

Disassembly and reassembly is as shown in Fig. 7.

Using a wrench on the hex of the spring cap, unscrew the spring case. All parts down to and including the diaphragm will remain in the spring case.

Remove the thrust plate, then unscrew the retainer and remove the seat with the pin.

Inspect the regulator as follows:

1. Thorough cleaning of all parts is essential. Make sure that small orifices are open.
2. Make sure all diaphragm, gaskets, "O" rings and other non-metal parts are not brittle, cracked or misshaped.
3. Do not use any oil on the internal parts of the regulator.
4. Use pipe thread compound (pipe dope) on all pipe threaded fittings as they are assembled.

Replace the seat and pin by installing the retrofit kit, then reassemble the regulator. Always pressure test a regulator that has just been repaired. Use the list of symptoms above as a check list.



**Fig. 8 - DIFFERENTIAL STICKING TESTER
(EXPLODED VIEW)**
(Refer to Section 7 for Identification of Numbered Items)

SECTION 7 PARTS LIST

(Item Numbers Refers to Fig. 8)

ITEM NO.	PART NO.	DESCRIPTION
1		STAGE, LEGS & BASE
2	38412	CO ₂ PRESSURIZED ASSEMBLY
3	H5002	RETAINER WRENCH
4	21158	LEVER
5	21161	CELL BODY
6	21162	CELL CAP
7	21163	CELL SCREEN HOLDER
8	21164	FILTER RETAINER RING
9	21157	FLAT BOTTOMED TORQUE PLATE
10	21152	RUBBER RING
11	21153	PLASTIC RING
12	30209	SUPPORT SCREEN
13	21154	LOCKING MESH DISC
14	21155	* POSITION YOKE ASSEMBLY
15	21159	SPHERICAL TORQUE PLATE
16	N8805	HEAVY FILTER PAPER
17	38713	VALVE STEM
18	L4503	"O" RING 3/16 X 5-1/16 X 1/16
19	L4606	"O" RING 2-1/4 X 2-1/2 X 1/8
20	A5002	5/16-18 X 3/8 S.S. ALLEN CAP SCREW
21	L4507	"O" RING 1/2 X 3/8 X 1/16
22	L4638	"O" RING 3-3/4 X 3-1/2 X 1/8
23	L4330	SPANNER WRENCH
24	L4325	TORQUE WRENCH
25	33601	BOX OF CO ₂ CARTRIDGES
26	A5004	5/16-18 X 3/4 SS BOLT
27	38734	LOCK PIN
28	P8001	LOCK WASHER, 5/16
29	N3000	GRADUATED CYLINDER, 25 ml TC
30	L4301	SOCKET, 5/16

For more information, please contact us:

[ExpotechUSA](#)
[10700 Rockley Road](#)
[Houston, Texas 77099](#)
[USA](#)

[281-496-0900 \[voice\]](#)

[281-496-0400 \[fax\]](#)

E-mail: sales@expotechusa.com

Website: www.ExpotechUSA.com