

# **RAPID DIGESTORS**

Model 23012 Rapid Digestor-25 without digestion tubes

Model 23080 Rapid Digestor - 4 without digestion tubes

## **INSTRUCTION MANUAL**

Product designs are subject to change without notice

Form 23058 REV H / ECO A652

For more information, please contact us:

[ExpotechUSA](#)  
[10700 Rockley Road](#)  
[Houston, Texas 77099](#)  
[USA](#)

[281-496-0900 \[voice\]](#)

[281-496-0400 \[fax\]](#)

E-mail: [sales@expotechusa.com](mailto:sales@expotechusa.com)

Website: [www.ExpotechUSA.com](http://www.ExpotechUSA.com)

## ***TABLE OF CONTENTS***

---

Preface	4
General Description	5
Detailed Operational Function	5
Digestion Unit	5
Control Unit	6
Digestion Tubes, Flask Rack, and Retainer Plate	6
End Plates	7
Fume Removal System (Optional Equipment)	7
Specifications Digester 25 - Place	8
Specifications Digester 4 – Place	9
Installation	10
Unpacking	10
Operation & General Kjeldah Digestion Procedure	11
General Digestion for Feed, Grain	11
Routine Maintenance	13
Calibration	13
Troubleshooting	14
Service	
Main Power Switch Replacement	15
Strip Heater Replacement	15
Indicator Lamp Replacement	15
Resistor Replacement	16
Ceramic Heater Replacement	16
Sensor Replacement	16
Parts and Service	17
References	18
Replacement Parts	19
Wiring Diagrams	21
Warranty	29
Shipping Claims	30

## ***PREFACE***

---

Thank you for displaying confidence in us by selecting a Labconco Rapid Digester. Our design engineers, assemblers and inspectors have utilized their skills and years of experience to ensure that the new Labconco Rapid Digestors meets our high standards of quality and performance.

### **IMPORTANT NOTICE**

This manual should be read carefully by all the end users in order to become familiar with the operation of the Rapid Digestors. Recommendations are made within the manual to help you obtain maximum performance and life from your product.

We have included sections on initial set up, operation, maintenance and troubleshooting to provide you with all the tools necessary to achieve maximum performance.

**WARNING: THE DISPOSAL OF SUBSTANCES USED IN CONNECTION WITH THIS EQUIPMENT MAY BE GOVERNED BY VARIOUS FEDERAL, STATE OR LOCAL REGULATIONS. ALL USERS OF THIS EQUIPMENT ARE URGED TO BECOME FAMILIAR WITH ANY REGULATIONS THAT APPLY IN THE USERS AREA CONCERNING THE DUMPING OF WASTE MATERIALS IN OR UPON WATER, LAND OR AIR AND TO COMPLY WITH SUCH REGULATIONS.**

### **General Description**

The Rapid Digestors are designed for wet digestions on material such as feeds, grains, soils, plant tissues, water effluent, organic wastes, and food products. These digestions are made prior to analysis for nitrogen, calcium, phosphorus, heavy metals, micro-nutrients, and other materials. The system consists of a control unit, a heating unit with digestion tubes, and a flask rack for transporting tubes. The flask rack is equipped with removable side panels providing increased heat transfer to the upper part of the digestion tubes.

The heating unit consists of individual heaters constructed of ceramic materials providing uniform and efficient heat transfer to the digestion tubes. The heaters are encased with an efficient insulating material on four sides and the bottom to prevent heat loss, assuring low energy consumption and safe casing temperatures. The close tolerance fit between the inner ceramic tube and the digestion solution provides for shorter digestion times and uniform digestion temperatures of the sample solution. The heating unit is enclosed in a chemically etched aluminum casing, assuring easily cleaned surfaces with no paint to flake off and providing a good appearance throughout the unit's lifetime.

The control unit is of solid state design and regulates the temperature of the individual heaters uniformly and accurately. The large temperature set point dial assures accurate and repeatable temperature settings. The unique light display located on the heating unit assures accurate temperature setting and allows for visual observation of the Digestor's operation.

The digestion tubes are thick-walled, rimmed, and made of borosilicate glass. Each tube is manufactured to close tolerances to assure efficient and uniform digestions. Digestion tubes are of the straight non-constricted type of approximately 250-ml capacity or with construction and an accurate volumetric mark placed at 250-ml volume.

### **Detailed Operational Function**

The Labconco Digestor consists of the digestion unit, the control unit, and accessories (digestion tubes, flask rack, end plates, and retainer plate). The digester can simultaneously handle up to 25 samples, each weighing up to 5 g for solid materials or approximately 25 ml for liquid samples.

### **Digestion Unit**

The digestion unit contains electrically heated ceramic cores retained in a pan insulated from the aluminum casing to reduce heat loss and to prevent the metal casing from becoming hot. The ceramic cores are precision molded to accommodate the digestion tubes and provide maximum direct contact with the tubes.

The center heating element with the 25-Place, or the rear left with the 4-Place, contains a RTD platinum sensor that is encased in ceramic to sense the temperature of the digester and signals the control unit providing uniform temperature control.

## ***INTRODUCTION***

---

**CAUTION:** The top surface of the digester is hot during operation and for a period of time after shutdown. To avoid the possibility of burns, do not touch the surface with bare hands.

The exposed surfaces of the unit are made of aluminum finished by a chemically etched process to withstand corrosion. The light(s) located on the front of the digester indicates when the digester has reached set-point temperature and any malfunction that could occur, along with providing over and under temperature set-point indications. Flashing of the light(s) indicates proper temperature control.

### **Control Unit**

The solid state proportional controller regulates the temperature of the digester unit. The Rapid Digester-25 control unit is factory set to accept 208/240 volts, 50/60 Hz requiring 20 amp fusing and the 4-Place set to accept 115 volts, 50/60 Hz requiring 15 amp fusing. Temperatures from a few degrees above ambient to 450° C can be set on the set point indicator dial. Each controller is factory calibrated for proper temperature setting before leaving the factory and should not require re-calibration. A calibration resistor is provided for a calibration check of the set-point temperature if required. (Refer to Maintenance Section of manual for procedure). A red indicator light on the front panel of the control unit is illuminated when unit is energized. Flashing of the light(s) located on the digester unit indicates the set-point temperature, when it has been reached, the temperature of the digester is proportionately controlled by the controller.

### **Digestion Tubes, Flask Rack, and Retainer Plate**

Digester Model 23006 is supplied with one set of thick-walled, heavy rimmed, heat resistant glass digestion tubes with volumetric calibration marks at 250-ml volume. Digester Model 23000 is supplied with tubes having the same features as with Model 23006 except without calibration markings. Models 23012 and 23080 are supplied without digestion tubes. The heavy rims allow the tubes to hang in the stand when the rack is lifted. The flask rack is constructed of aluminum alloy and holds the tubes during digestion as well as during cooling, dilution, washing, drying, and weighing of samples. Samples are weighed or volumetrically delivered into the tubes and the digestion mixture added. The tubes in the rack are then lowered into the digester unit. The samples are digested at the proper temperature for a predetermined amount of time. Digestion temperature and time is determined by the type of sample being digested. After digestion is complete, the flask rack containing digested samples must be removed from digester, cooled and diluted with water. The digestion is now complete and ready for appropriate determination. The retainer plate (Rapid Digester 25-Place only) is attached to the digester flask rack to lock the tubes in place, allowing the tubes to be emptied, washed, and dried as a unit, without removal from the rack. The retainer plate is not to be used during digestion, cooling or dilution of the samples.

### **End Plates**

The end plates are rectangular aluminum plates that attach to the open ends of the flask rack during digestion. Closing the open ends of the rack promotes proper refluxing to wash down the sides of the tubes for complete and efficient digestions. The end plates are removed during cooling, dilution and washing.

### **Fume Removal System (Optional equipment)**

An optional fume removal system is available to provide removal of the corrosive fumes expelled during a digestion. The use of this system is highly recommended to prevent damage to conventional fume removal hoods.

## ***SPECIFICATIONS***

---

### **Specifications (Rapid Digester, 25-Place)**

#### **1. Electrical**

Operating Voltage:	208-240V AC single phase
Current (Max.):	16 Amp at 230V AC
Fusing:	25 Amp fuses @208 or 240V AC operation
Frequency:	50 or 60 Hz

#### **2. Physical**

Weight:	Digestion Unit:	78 lbs.
	Control Unit:	10.8 lbs.
Size	Tubes:	9.2 lbs./set of 25
	Flask Rack:	3.6 lbs.
	End Plates:	1.4 lbs.
	Digestion Unit:	8" H x 19-1/4"W x 19" D
	Control Unit:	5-1/8"H x 8" W x 12-1/8"D
	Flask Rack:	6-1/2"H x 14-1/4"W x 14-1/4"D
	Flask Rack w/ handles	6-1/2"H x 17-3/4"W x 14-1/4"D
	End Plate:	6-1/2"H x 14-9/16"W x 1"D
	Tubes: Volumetric	11-15/16"L x 1.65 OD
	Straight	11-15/16"L x 1.65 OD
Sample Size:	Up to 5 grams	

#### **3. Features**

Digestion Tubes (Types)	250 ml straight 250 ml constricted with volumetric mark
Capacity (samples/digestion)	25
Temperature range	Ambient to 450°C
Heat-up time to 410°C	Approximately one hour
Temperature readout	Set point dial with indication lamps

**Specifications (Rapid Digester 4-Place)**

**1. Electrical**

Operating voltage:	115V AC
Current (Max.):	6 Amp @ 115V AC
Fusing:	8 Amp @ 115V AC
Frequency:	50 or 60 Hz

**2. Physical**

Weight (Shipping):	30 Lbs.
Size:	Digestion Unit: 6-3/8"H x 9"W x 11-1/4"D
	Control Unit 4-3/4"H x 6-3/4"W x 8-1/8"D
	Sample size: Up to 5 grams

**3. Features**

Digestion tube (types)	250 ml straight
	250 ml constricted with volumetric mark
Capacity (samples/digestion)	4
Temperature range	Ambient to 450°C
Heat-up time to 410°C	Approximately 45 minutes
Temperature readout	Set point dial with indication lamps

## ***INSTALLATION***

---

### **Unpacking**

Use caution when unpacking the digester and accessories to avoid damage. Remove the digester unit from the carton first and carefully inspect all packing material to insure that no accessories or small parts are discarded by accident. If damage from shipping has occurred, the customer must file a claim with the carrier IMMEDIATELY! Do not return any item to Labconco Corporation without written authorization from the factory. Your local laboratory apparatus dealer can assist you and should be contacted if problems occur.

### **Installation**

- Locate the digester unit under a suitable fume removal system to assure complete removal of fumes and vapors given off during the digestion.

<p><b>CAUTION:</b> Acid fumes given off during digestion are very corrosive. Digestion unit must be placed in venting system that is totally resistant to acid fumes or damage will result to the removal system. It is highly recommended that Labconco's fume removal system, designed for acid removal from digestors, be used in conjunction with a laboratory fume hood.</p>
-----------------------------------------------------------------------------------------------------------------------------------------------------------------------------------------------------------------------------------------------------------------------------------------------------------------------------------------------------------------------------------

- Locate control unit outside hood away from any vapors or fumes. Damage to control unit will result if subjected to corrosive vapors or fumes.
- Connect power cord from control unit to digester unit. Remove calibration resistor from 2-pin connector located on rear of control unit. Connect small diameter gray sensor cord to the 2-prong receptacle provided.
- Connect main power cord from control unit to suitable electrical outlet. (208-240V AC 3-wire installation fused at 25 amps for the 25-Place digester or 115V AC for the 4-Place. Refer to electrical specifications pages 5 & 6).
- Adjust temperature set-point dial to approximately 300°C. Turn switch to ON position. Red pilot light on controller panel will be illuminated along with the red light(s) on the Digester's front panel.
- Allow approximately 40 minutes for unit to reach temperature setting. When unit reaches temperature, the light(s) on the digester unit will flash. When light(s) are on, one half of the time the temperature indicated on the temperature dial has been reached.
- Place digestion tubes in flask rack. System is now ready for operation.

**Operation and General Kjeldah Digestion Procedure for Nitrate Free Samples 1 - 2**

**General Digestion for feed, grain, etc.**

1. Turn main power switch located on front of controller to ON position. Set temperature to 410°C using temperature set point dial on controller. Allow approximately one hour for unit to reach pre-set temperature (digestor at pre-set temperature when light(s) located on front of digestor is flashing).
2. Carefully insert the digestion tubes into the holes provided in the flask rack. The flask rack can be used for convenient handling and transportation of the digestion tubes.
3. Place weighed, well ground homogenous samples into digestion tubes and add 9g K<sub>2</sub>SO<sub>4</sub>, 0.42 g Hg<sub>0</sub>, and 15 ml H<sub>2</sub>SO<sub>4</sub>.
4. After completing sample and reagent addition to the digestion tubes, carefully elevate the rack by grasping the handles provided and place in position on the digestor unit. As the rack is lifted, each tube will rest on its top rim. Carefully lower rack so that each tube enters its respective hole and bottoms in the base of the unit.
5. If optional fume removal system has been purchased, place system on top of the digestion tubes. Alignment is accomplished by a side to side, front to back motion. Adjust water flow to aspirator to the point where all fumes are removed. (Refer to instruction manual for Fume Removal System).
6. Place end plates on flask rack. These plates completely close the ends of the flask rack and allow the temperature of the upper portion of the tube to elevate providing for proper refluxing and condensation of the H<sub>2</sub>SO<sub>4</sub> which washes the carbonized material back into the digestion solution. (A certain amount of roaming will occur at the beginning of the digestion. The refluxing of the acid washes any carbonized material back into the digestion solution. If foaming is uncontrollable, reduce digestion temperature and/or sample size).
7. Digest sample at 410° for 45 minutes for complete recovery of all types of nitrogen containing samples. (Digestion time may be less for those samples not containing refractory nitrogen. Refer to Labconco's extracts).

*Official Methods of Analysis of the Association of Official Analytical Chemists,*  
Thirteenth Edition, Washington, District of Columbia, 1980.

Methods utilizing copper as the catalyst and 20 minute digestions refer to reference section of this manual and request appropriate Labconco extracts.

8. After digestion is complete, remove flask rack containing tubes from digestor and place on heat resistant pad. Avoid having the hot tubes come into contact with a cool or wet surface. (As a safety precaution, wear asbestos gloves and goggles when removing the rack and tubes from the digestor).

## ***NORMAL OPERATION***

---

9. Allow tubes to cool for 5-8 minutes. Dilute digest with approximately 100-ml water when tubes are cool enough to handle. Dilution must be made before a cake is formed from precipitated salts, but not before the digest is cool enough to contain the exothermic reaction. (The cooling period is very important since, in the determination procedure, caking of the salts will cause low recoveries of the nitrogen contained in the cake.
10. After dilution of the digested sample, the nitrogen content can be determined by Labconco's Rapid Distillation Apparatus, normal Kjeldahl distillation, specific ion electrode, steam distillation, or by manual or automated colorimetric determinations. The general method presented for the digestion of total Kjeldahl nitrogen is a basic method being used in many laboratories doing feeds and grain digestions.

Periodic cleaning of the surface is necessary to avoid stains from acid spills. This is best accomplished with a detergent and water solution when the unit is cool. (Disconnect unit from electrical source).

It is necessary to keep the cores of the ceramic heaters clear of any foreign material to assure free insertion of the digestion tubes.

**Calibration:** The controller has been factory calibrated and should not require re-calibration. In the event re-calibration is required the following procedure should be followed:

1. Insert calibration resistor into the 2-pin sensor connector located on the rear of the control unit.
2. Place ON-OFF switch, located on the controller, to the ON position.
3. Adjust set-point indicator dial to a position where the indicator lights, located on front panel of digester, are illuminated 50% of the time.
4. Loosen setscrews on set-point indicator dial and align calibration mark on dial with pointer label. For calibration of Rapid Digester 4-Place, align 220°C mark on dial with pointer label. Retighten setscrews.
5. The digester is now calibrated to give digestion temperature indicated on set-point dial.

## ***TROUBLESHOOTING***

---

<b>Symptom</b>	<b>Probable Cause</b>	<b>Corrective Measure</b>
Main pilot light does not illuminate.	ON-OFF switch in off position	Turn switch to ON position
	Main power fuse blown or circuit breaker tripped	Replace fuse or reset circuit breaker
	25 Amp fuse on control unit blown (8 Amp on Rapid Digestor 4-Place)	Check continuity of fuse with ohmmeter. Replace fuse if blown. If fuse continues to blow, locate cause.
No heat applied to unit. Main pilot light illuminated	ON-OFF switch defective	Replace switch. Refer to Service Section for replacement procedure.
	Sensor defective	Check continuity of sensor by placing ohmmeter across pins 1 & 2 of female sensor receptacle. If resistance measurements show sensor to be open, replace sensor by following Service Section on Sensor Replacement.
Indicator lamp not illuminated.	Bulb defective	Check continuity of bulb with ohmmeter and replace if defective following Service Section-Indicator Lamp Replacement.
	Defective resistor	Check continuity of resistor for the row of heaters behind indicator lamp not illuminated using ohmmeter.
	Defective ceramic heater	Check continuity of each heater contained in the row behind indicator lamp that is not illuminated. Replace defective heater following Ceramic Heater Replacement section.
Uneven heat applied to unit (not applicable to Rapid Digestor 4-Place)	Strip heater defective	Check continuity of each strip heater and replace defective heater following Strip Heater Replacement section.

Refer to appropriate wiring diagrams or layout drawing for clarification.

**Main Power Switch Replacement**

- Disconnect main line cord from receptacle.
- Remove the #10-24 machine screws from sides of control unit and remove inner panel exposing switch.
- Remove wires from old switch and replace switch.
- Rewire new switch referring to wiring diagram located on page 21 of manual. (Refer to page 25 for Rapid Digester 4-Place wiring diagram).
- Reassemble control unit.
- Reconnect main power supply.

**Strip Heater Replacement (Not applicable to Rapid Digester 4-Place).**

- Disconnect main line cord from receptacle.
- Remove screws from sides of digester and raise inner panel forward exposing indicator lamp housings.
- Disconnect spade terminals to indicator lamp freeing the inner panel for complete removal.
- Remove the six screws from bottom of digester freeing heater containment pan.
- Tilt heater containment pan to expose wiring.
- Trace wiring to defective heater and disconnect heater wiring.
- Remove heater, replace and rewire.
- Reassemble in reverse order starting with number 3.
- Reconnect main power supply.

**Indicator Lamp Replacement**

- Disconnect main line cord from receptacle.
- Remove lens cap from defective bulb.
- Remove defective bulb from housing and replace.
- Reinstall lens cap.

## ***SERVICE***

---

- Reconnect main power supply.

### **Resistor Replacement**

- Follow steps 1-5 under “Strip Heater Replacement”.
- Remove defective resistor from buss bar and terminal strip.
- Install new resistor, retighten screws and reassemble in reverse order.
- Reconnect main power supply.

### **Ceramic Heater Replacement**

- Follow steps 1-5 under “Strip Heater Replacement”.
- Remove defective heater from heater containment pan.
- Install new heater by threading wires through hole in the bottom of the insulator board. Feed wires through hole and lower heater in place.

**CAUTION:** Do not bend wires or allow wires to fold up between bottom of heater casing and insulator board. Heater life will be greatly reduced if heater is not installed correctly.

- Reconnect heater wires and reassemble in reverse order.
- Reconnect main power supply.

### **Sensor Replacement**

- Follow steps 1-5 under “Strip Heater Replacement”.
- Disconnect sensor leads attached to 2-pin connector located on left side of digester. (2-pin connector located on rear of Rapid Digester 4-Place).
- Remove heater containing the sensor. (Refer to layout sketch on page 23 for 25-Place or to page 27 for 4-Place). Heater-sensor assembly containing defective sensor may be used as heater only by breaking sensor flush with bottom of heater.
- Install new heater sensor assembly by carefully threading wires through holes in the bottom of the insulator board. Feed wires through holes and lower heater in place.

**CAUTION:** Do not bend wires or allow wires to fold up between bottom of heater casing and insulator board. Heater and sensor life will be greatly reduced if heater is not installed correctly.

- Reconnect heater wires and solder sensor wires to the 2-pin connector.
- Reconnect main power supply.
- Recalibrate unit by following calibration procedure in Maintenance Section of this manual.

### **Parts and Service**

- If a problem should arise, please contact your local laboratory apparatus dealer through whom you purchased the Labconco products. Please include Labconco catalog and serial numbers on all phones or letter inquiries to obtain prompt action on your particular unit. Consult nameplates to obtain this information. If contacting Labconco directly, please furnish the name of the dealer from whom you purchased the equipment.

**WARNING: PERCHLORIC ACID IS A VERY RAPID OXIDIZER. IT COMES TO A BOIL AT RELATIVELY LOW TEMPERATURES, WITH THE LIQUID CONTENTS TOTALLY EVAPORATED IN A SHORT AMOUNT OF TIME. THE RESIDUE WHICH REMAINS AFTER THE LIQUID IS DRAWN OFF BECOMES ANHYDROUS AND VERY UNSTABLE.**

**FOR THIS REASON, LABCONCO WARNS AGAINST THE USE OF PERCHLORIC ACID WITH THIS EQUIPMENT AS A REACTION COULD RESULT.**

## ***REFERENCES***

---

*Official Methods of Analysis of the Association of Official Analytical Chemists*, Thirteenth Edition, Washington, D.C., 1980.

Hambleton, L.G. and Noel, R. J., *Journal of the Association of Analytical Chemists*, 58: 143-145, 1975.

Noel, R.J. , and Hambleton, L.G., *Journal of the Association of Analytical Chemists*, 59: 134-140, 1976.

*Semi-Automated Method for Total Protein Nitrogen in Feeds - Applications* Wall, L.L., Sr., Gehrke, C.W., and Smith, R.A., University of Missouri, Columbia, Experiment Station Chemical Laboratories, Columbia, Missouri.

“The Determination of Nitrogen Content from Predigested Samples with the Labconco Rapid Distillation Apparatus”, *Labconco Extracts 1:780*, Labconco Corporation, Kansas City, Missouri.

“Digestion Method for the Determination of Protein Nitrogen in Feeds, Grains, Cereals, and Grasses Utilizing the Labconco 4-Place Rapid Digester”, *Labconco Extracts 2:880*, Labconco Corporation, Kansas City, Missouri.

“Digestion Method for the Determination of Protein Nitrogen in Feeds, Foods, Grains, Cereals, and Grasses Utilizing the Labconco 25-Place Rapid Digester”, *Labconco Extracts 3:880*, Labconco Corporation, Kansas City, Missouri.

**Rapid Digestor 25-Place**

**DIGESTOR - \*1**

<b><u>Catalog No.</u></b>	<b><u>Description</u></b>
12761	Lens Cap, Red
12762	Indicator Lamp
23034	Heater Assembly with sensor cemented in place
13249	Resistor, 2 ohm 20 W
13459	Strip, Heater
23020	Assembly, Heater
23030-25	Tube Digestion, 250 ml volumetric (Pkg. of 25)
23040-25	Tube, Digestion with NO volumetric marking. (Pkg. of 25)
23051	Flask Rack

**CONTROLLER - \*2**

<b><u>Catalog No.</u></b>	<b><u>Description</u></b>
12707	Pilot Light, 230V
13240	Switch, DPST
23119	Control Assembly
23032	Calibration Resistor

\*1. Refer to page 24 for digestor parts identification.

\*2. Refer to page 23 for controller parts identification.

## ***REPLACEMENT PARTS***

---

### **Rapid Digestor 4-Place**

#### **DIGESTOR - \*1**

<b><u>Catalog No.</u></b>	<b><u>Description</u></b>
12767	Lens Cap, Red
12766	Indicator Lamp
13249	Resistor, 2 ohm 20 W
23084	Assembly, Heater
23030-05	Tube Digestion, 250 ml volumetric (Pkg. of 5)
23040-05	Tube, Digestion with <u>NO</u> volumetric marking. (Pkg. of 5)
23097	Flask Rack

#### **CONTROLLER - \*2**

<b><u>Catalog No.</u></b>	<b><u>Description</u></b>
12769	Pilot Light, 120V
13257	Switch, DPST
23124	Control Assembly
23032	Calibration Resistor

\*1. Refer to page 28 for digestor parts identification.

\*2. Refer to page 27 for controller parts identification.



# WIRING DIAGRAM

## Wiring Diagram - Digestor

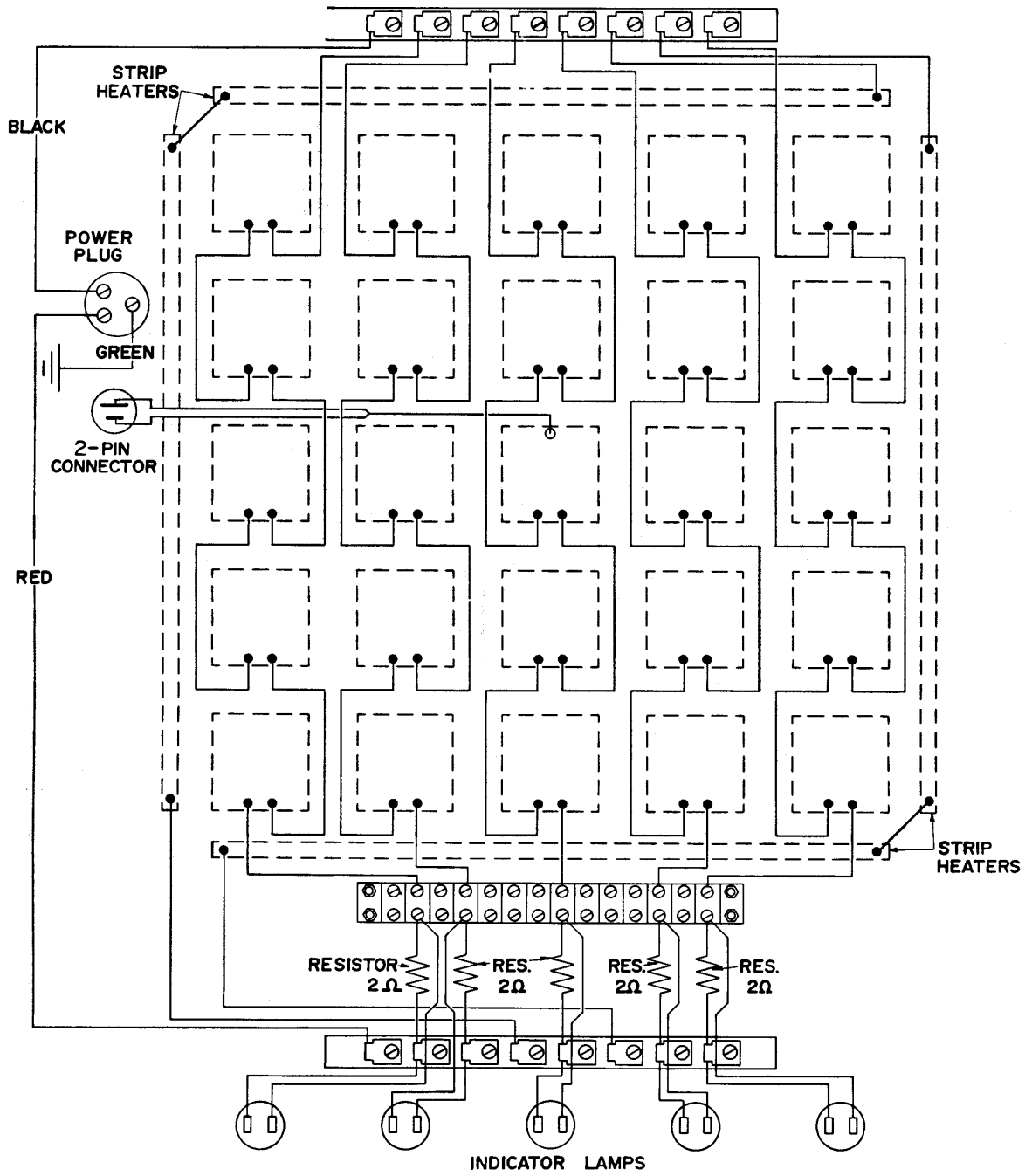

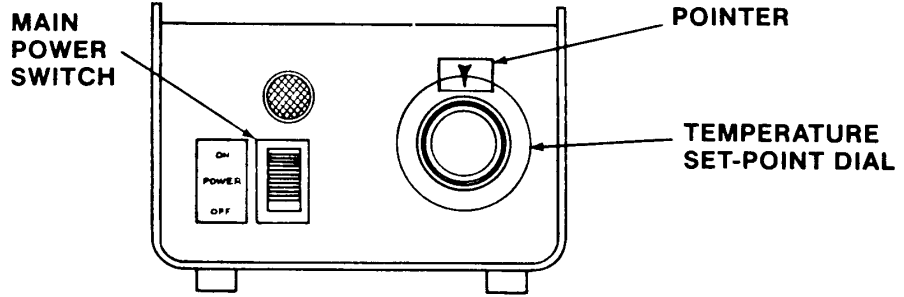

**CONTROLLER**  
FRONT VIEW OF UNIT

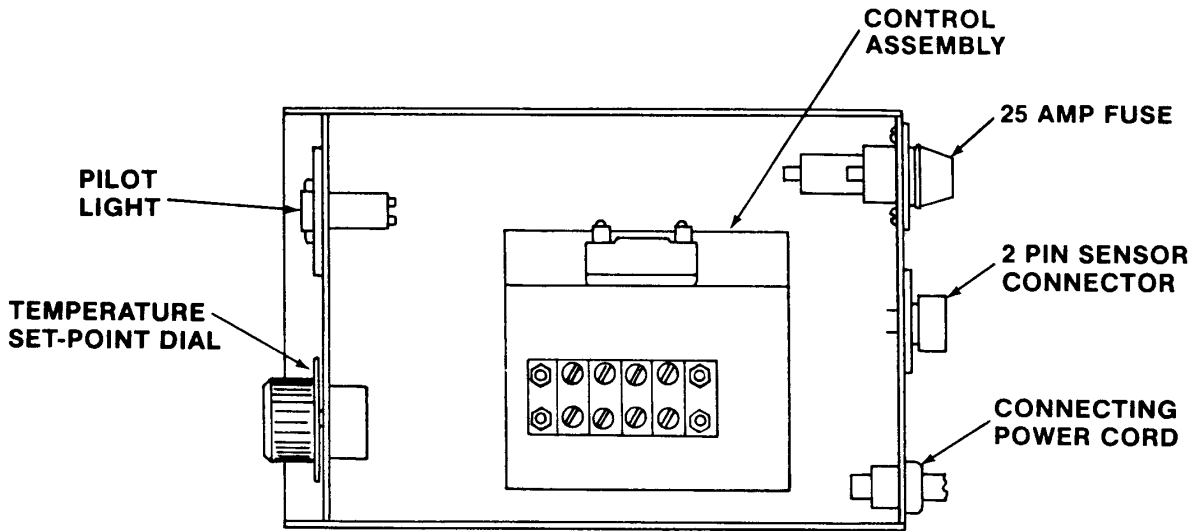

**CONTROLLER**  
TOP VIEW OF UNIT  
(TOP CUT-AWAY)

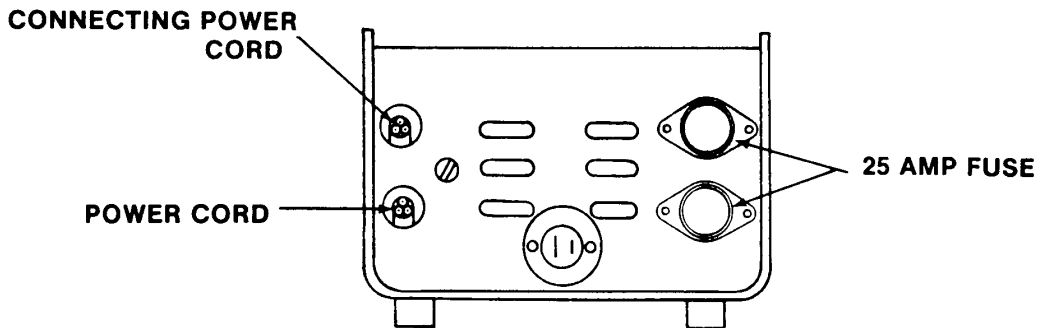

**CONTROLLER**  
BACK VIEW OF UNIT

# WIRING DIAGRAM

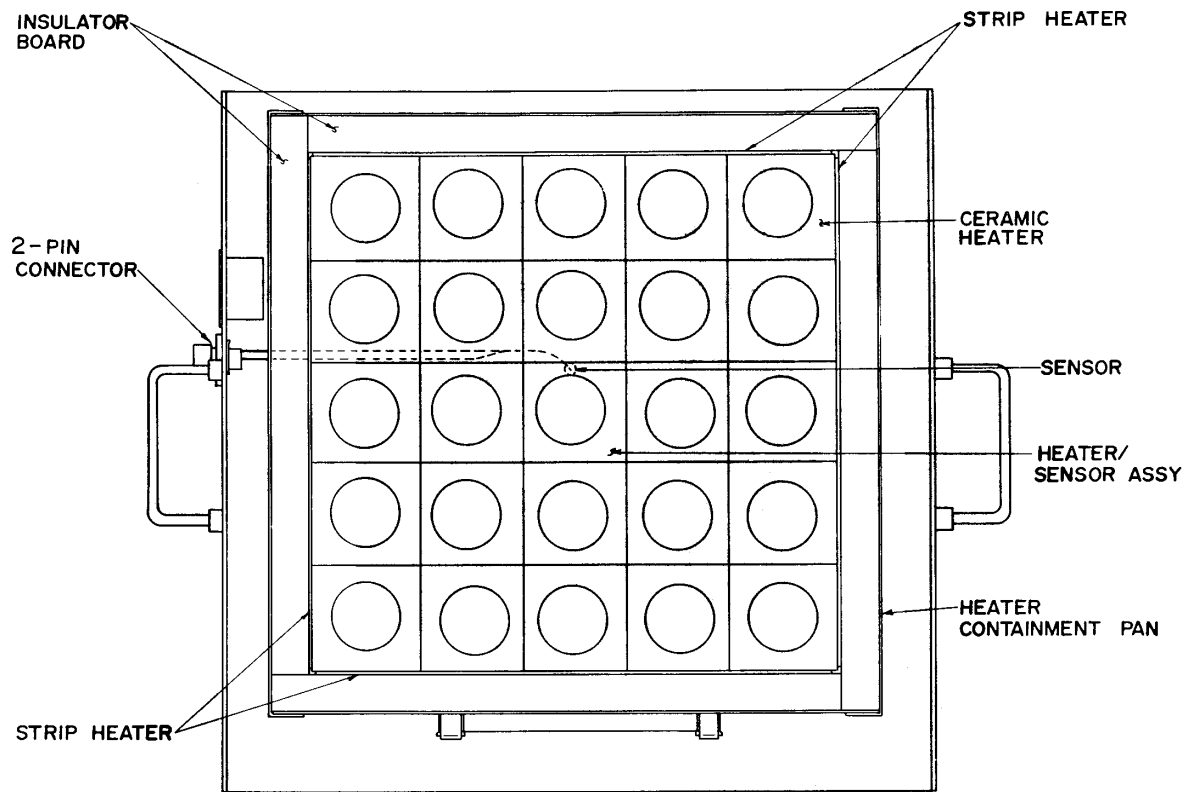

**DIGESTOR**  
TOP VIEW OF UNIT  
(TOP CUTAWAY)

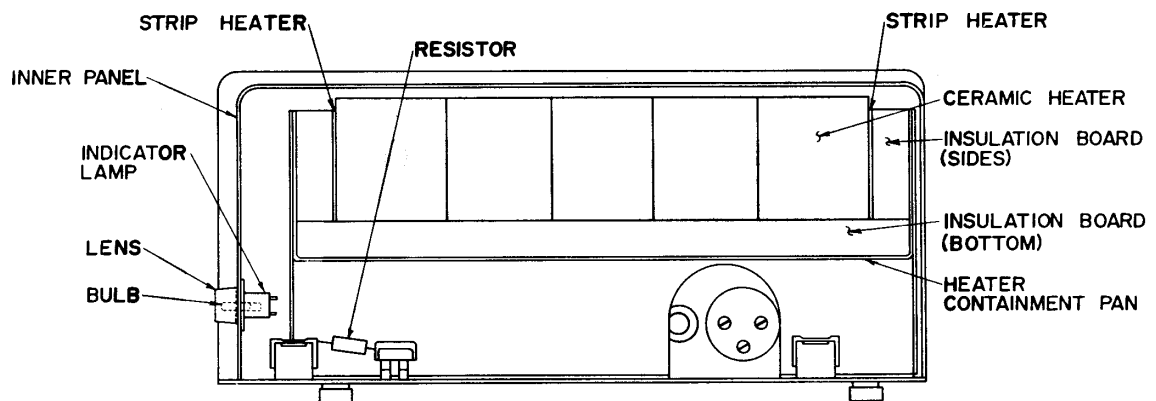

**DIGESTOR**  
SIDE SECTIONAL VIEW

# WIRING DIAGRAM

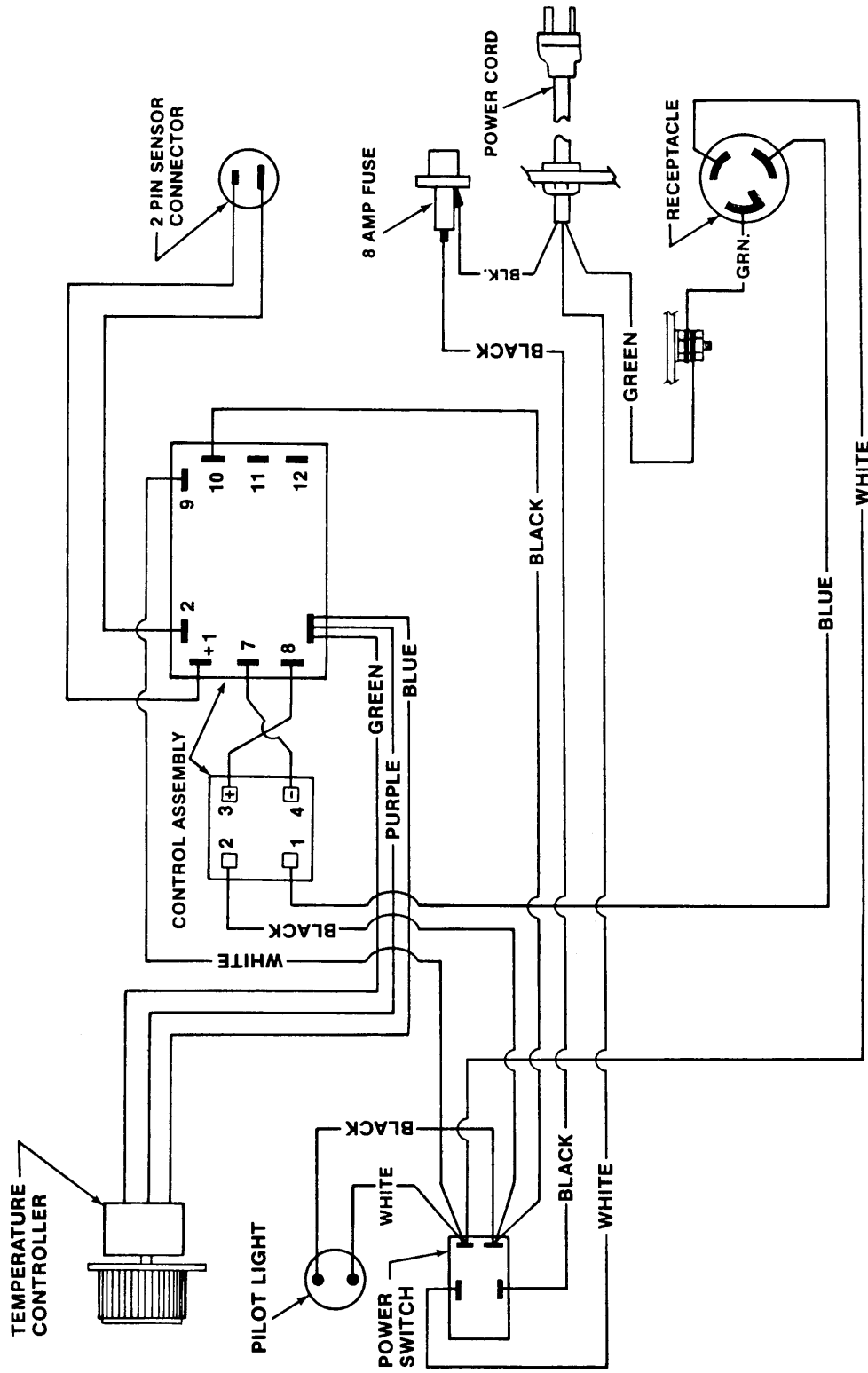

WIRING DIAGRAM — CONTROLLER

# WIRING DIAGRAM

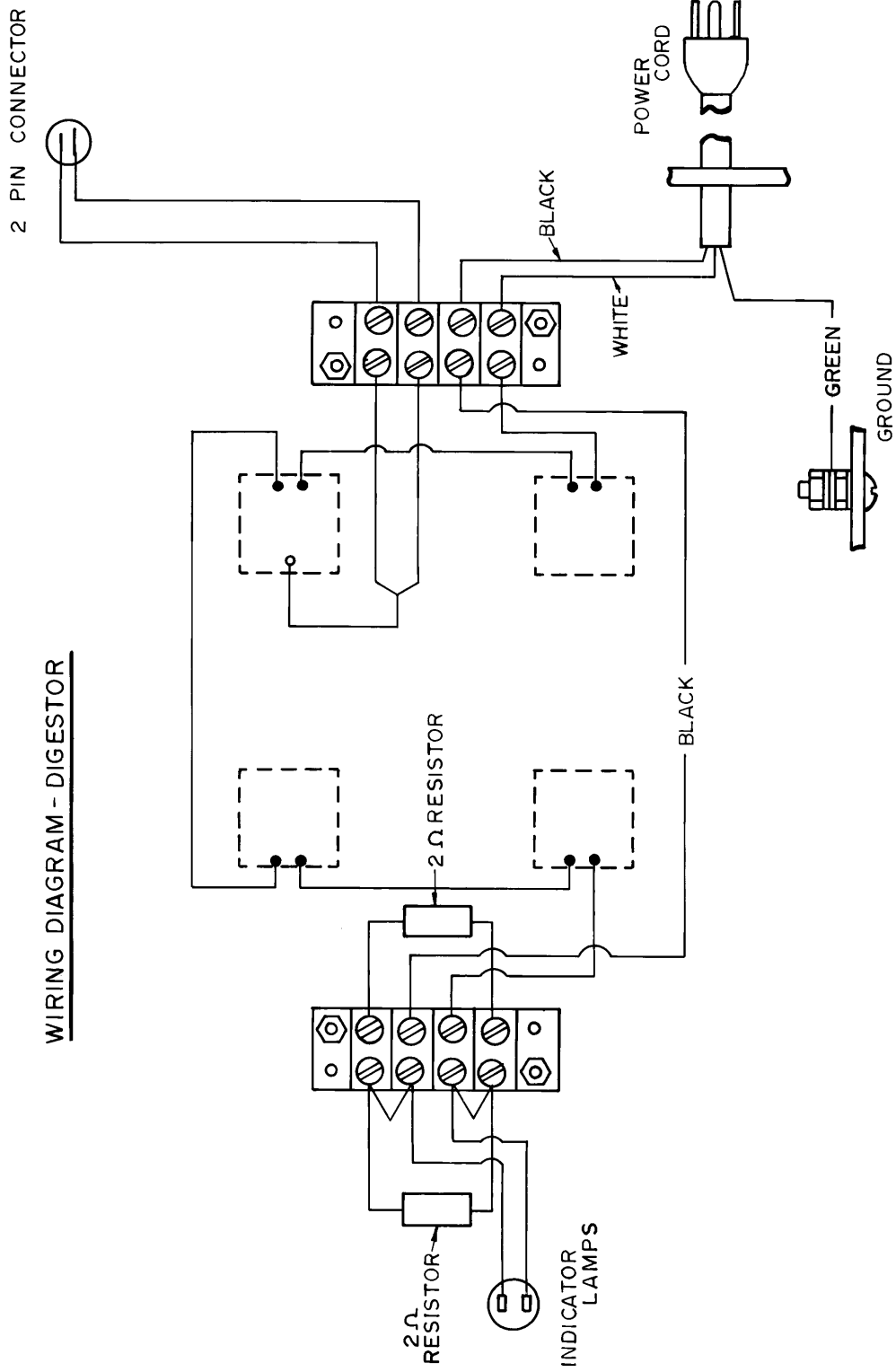

**WIRING DIAGRAM**

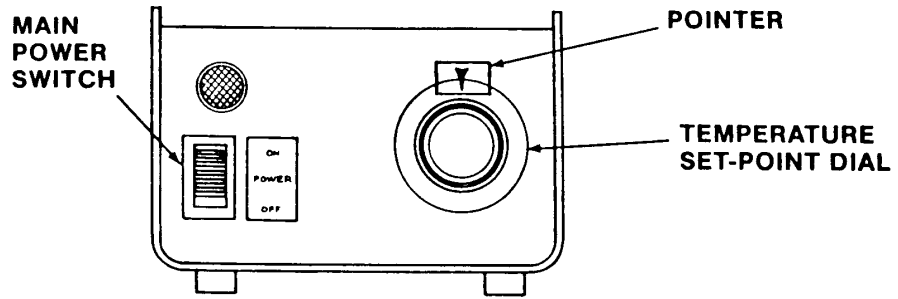

**CONTROLLER**  
FRONT VIEW OF UNIT

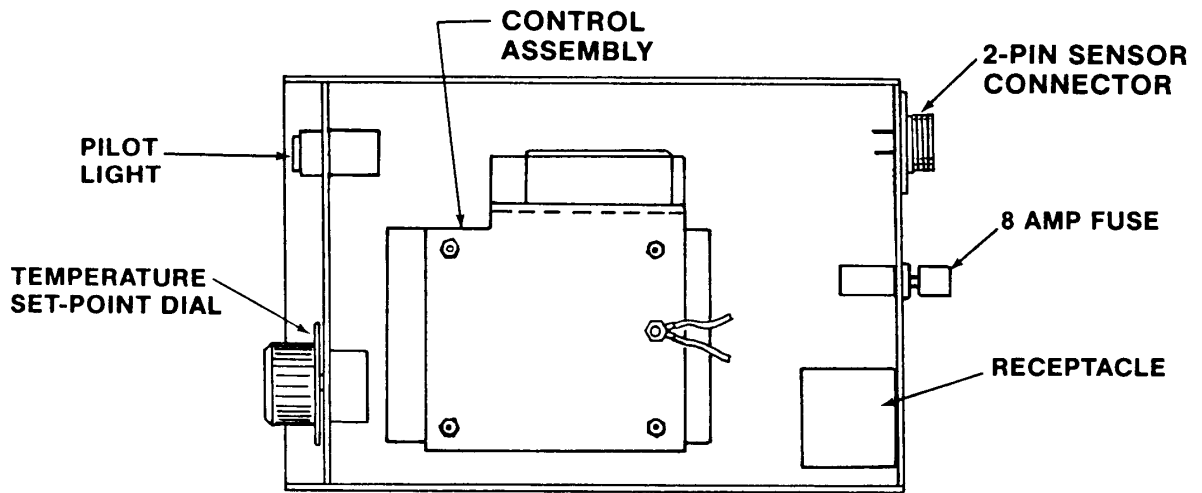

**CONTROLLER**  
TOP VIEW OF UNIT  
(TOP CUT-AWAY)

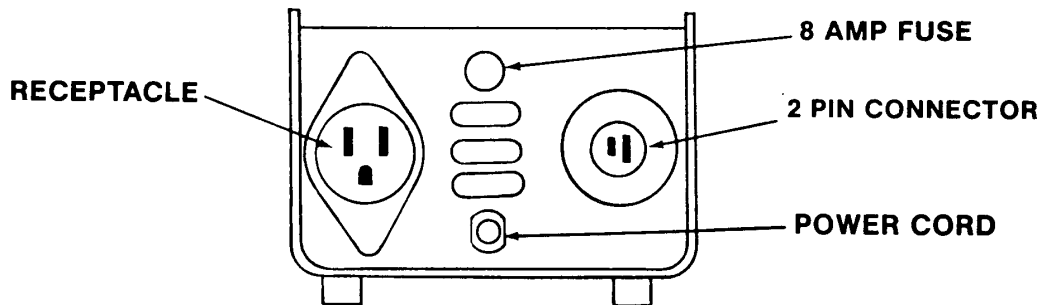

**CONTROLLER**  
BACK VIEW OF UNIT

# WIRING DIAGRAM

---

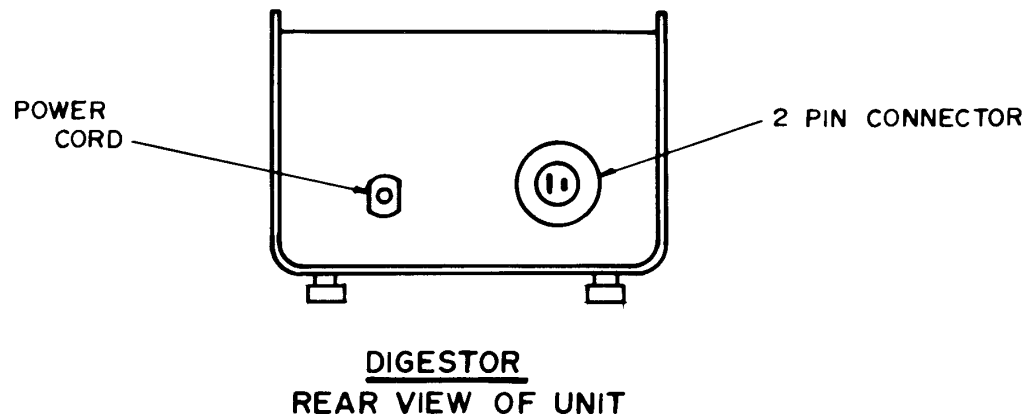
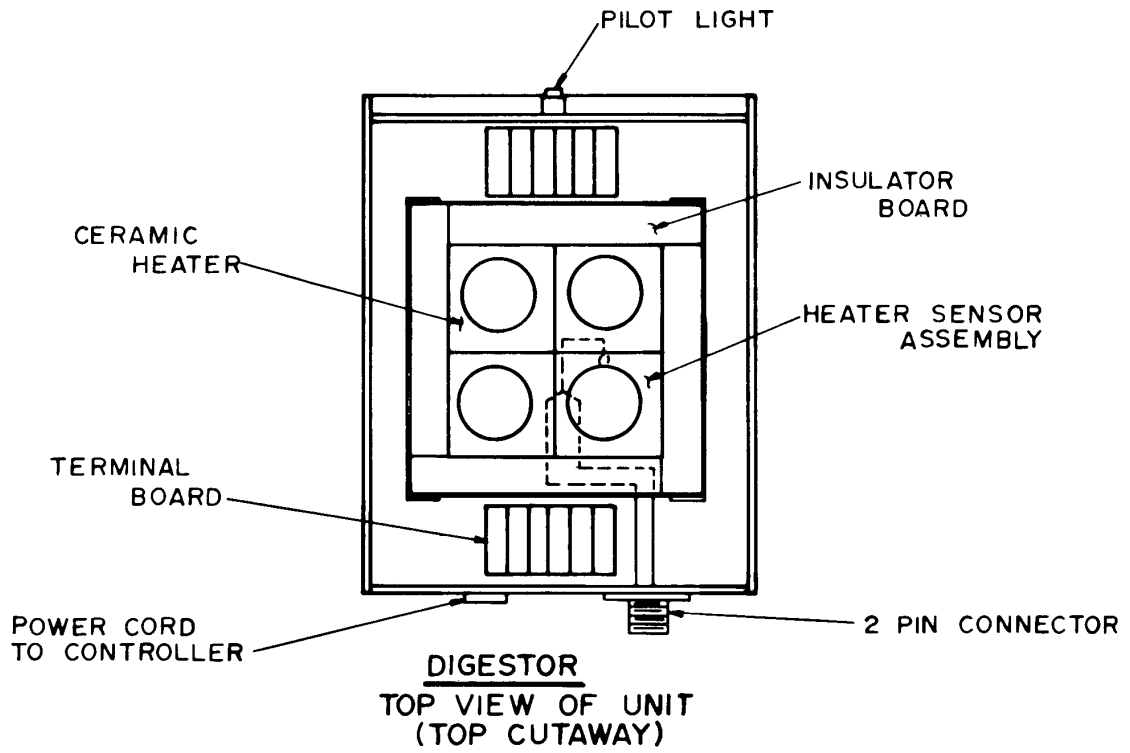

Labconco provides a warranty on all parts and factory workmanship. The warranty includes areas of defective material and workmanship, provided such defect results from normal and proper use of the equipment.

The warranty for all Labconco products will expire one year from date of installation or two years from date of shipment from Labconco, whichever is sooner, except the following:

- Purifier® Delta® Series Biological Safety Cabinets carry a three-year warranty from date of installation or four years from date of shipment from Labconco, whichever is sooner.
- Carts carry a lifetime warranty.
- Glassware is not warranted from breakage when dropped or mishandled.

This limited warranty covers parts and labor, but not transportation and insurance charges. In the event of a warranty claim, contact Labconco Corporation or the dealer who sold you the product. If the cause is determined to be a manufacturing fault, the dealer or Labconco Corporation will repair or replace all defective parts to restore the unit to operation. Under no circumstances shall Labconco Corporation be liable for indirect, consequential, or special damages of any kind. This statement may be altered by a specific published amendment. No individual has authorization to alter the provisions of this warranty policy or its amendments. Lamps and filters are not covered by this warranty. Damage due to corrosion or accidental breakage is also not covered.

## ***SHIPPING CLAIMS***

---

If a shipment is received in visibly damaged condition, be certain to make a notation on the delivering carrier's receipt and have their agent confirm the damage on your receipt. Otherwise, the damage claim may be refused.

If concealed damage or pilferage is discovered, notify the carrier immediately and retain the entire shipment intact for inspection. Interstate Commerce Commission rules require that the claim be filed with the carrier within 15 days after delivery.

**NOTE: Do not return goods.** Goods returned without prior authorization will not be accepted. Labconco Corporation and its dealers are not responsible for shipping damage. Claims must be filed directly with the freight carrier by the recipient. If authorization has been received to return this product, by accepting this approval, the user assumes all responsibility and liability for biological and chemical decontamination and cleansing. Labconco reserves the right to refuse delivery of any products, which do not appear to have been properly cleaned and/or decontaminated prior to return.

For more information, please contact us:

[ExpotechUSA](#)  
[10700 Rockley Road](#)  
[Houston, Texas 77099](#)  
[USA](#)

[281-496-0900 \[voice\]](#)

[281-496-0400 \[fax\]](#)

E-mail: [sales@expotechusa.com](mailto:sales@expotechusa.com)

Website: [www.ExpotechUSA.com](http://www.ExpotechUSA.com)