



# PURIFIER

HEPA-FILTERED SAFETY CABINETS, ENCLOSURES & CLEAN BENCHES



Protecting your  
laboratory environment

**LABCONCO**

For more information, please contact us:

[ExpotechUSA](#)  
[10700 Rockley Road](#)  
[Houston, Texas 77099](#)  
[USA](#)

[281-496-0900 \[voice\]](#)

[281-496-0400 \[fax\]](#)

E-mail: [sales@expotechusa.com](mailto:sales@expotechusa.com)

Website: [www.ExpotechUSA.com](http://www.ExpotechUSA.com)

# Biological Safety Cabinets, Enclosures & Clean Benches

## TABLE OF CONTENTS

Overview . . . . .	1
Selection Guide . . . . .	8
Purifier® Delta® Series Class II Biological Safety Cabinets Overview . . . . .	12
<b>Purifier® Delta® Series Class II, Type A2 Safety Cabinets</b>	
Introduction & Airflow Drawing . . . . .	19
Features & Benefits . . . . .	20
Ordering Information . . . . .	22
Installation Requirements . . . . .	23
Accessories . . . . .	24
Purifier® Delta® Series Class II, Type A2 & B2 Safety Cabinets Ductwork . . . . .	25
<b>Purifier® Delta® Series Total Exhaust Safety Cabinets</b>	
Introduction & Airflow Drawing . . . . .	27
Features & Benefits . . . . .	28
Ordering Information . . . . .	30
Accessories . . . . .	31
<b>Purifier® Class I &amp; HEPA Filtered Safety Enclosures</b>	
Introduction & Airflow Drawing . . . . .	33
Features & Benefits . . . . .	34
Purifier Class I Safety Enclosures Ordering Information . . . . .	35
Purifier HEPA Filtered Enclosures Ordering Information . . . . .	36
Accessories & Ductwork . . . . .	36
<b>PVC Total Exhaust Clean Benches: Purifier® Trace Metals Work Station, Purifier® Forensic Enclosure &amp; Purifier® Class 100 Chemical Station</b>	
Introduction & Airflow Drawing . . . . .	39
Features & Benefits . . . . .	41
Ordering Information . . . . .	42
Accessories & Ductwork . . . . .	42
<b>Purifier® PCR Enclosures</b>	
Introduction & Airflow Drawing . . . . .	45
Features & Benefits . . . . .	46
Ordering Information . . . . .	47
Accessories . . . . .	47
<b>Purifier® Vertical Clean Benches</b>	
Introduction & Airflow Drawing . . . . .	49
Features & Benefits . . . . .	50
Ordering Information . . . . .	51
Accessories . . . . .	51
<b>Purifier® Horizontal Clean Benches</b>	
Introduction & Airflow Drawing . . . . .	53
Features & Benefits . . . . .	54
Ordering Information . . . . .	55
Accessories . . . . .	56
Delta® Cart . . . . .	57
Telescoping Base Stands . . . . .	58
Electric & Manual Hydraulic Lift Base Stands . . . . .	60
Seismic Base Stands . . . . .	62
<b>Accessories for Purifier® Delta® Series Class II, Type A2 Safety Cabinets</b>	
Remote Blowers . . . . .	63
Canopy Connection Kits . . . . .	63
Air-Tight Damper . . . . .	63
Remote Blower for Purifier® Delta® Series Total Exhaust Safety Cabinets . . . . .	64
Remote Blowers for Purifier® Class I & HEPA Filtered Enclosures & PVC Total Exhaust Clean Benches . . . . .	65
<b>Dimensions</b>	
Purifier® Delta® Series Class II, Type A2 Safety Cabinets . . . . .	66
Purifier® Delta® Series Total Exhaust Safety Cabinets . . . . .	67
Purifier® Class I Safety Enclosures, Purifier® HEPA Filtered Enclosures . . . . .	68
Purifier® Trace Metals Work Station, Purifier® Forensic Enclosure, Purifier® Class 100 Chemical Station . . . . .	68
Purifier® PCR Enclosures, Purifier® Vertical Clean Benches . . . . .	69
Purifier® Horizontal Clean Benches . . . . .	69
Glossary . . . . .	70
References . . . . .	71
Index . . . . .	72

# Biological Safety Cabinets, Enclosures & Clean Benches

## OVERVIEW

### Laminar Airflow

The phrase “laminar flow” often is used to describe a type of equipment when it, in fact, refers to a specific airflow pattern. Laminar flow is defined as airflow in which the entire body of air within a defined space moves with uniform velocity in one direction along parallel flow lines.

### HEPA Filters—The Heart of Laminar Airflow Systems

The HEPA (High Efficiency Particulate Air) filter is a disposable dry-type filter, constructed of boron silicate microfibers cast into a thin sheet, much like a piece of paper. The filter media is folded, to maximize its surface area exposed to the air stream. Often aluminum separators are placed between the folds, to strengthen the filter, and allow the air to penetrate the deepest part of the fold. (Figure 1). The HEPA filter retains airborne particles and microorganisms, however, gases pass freely through the filter.

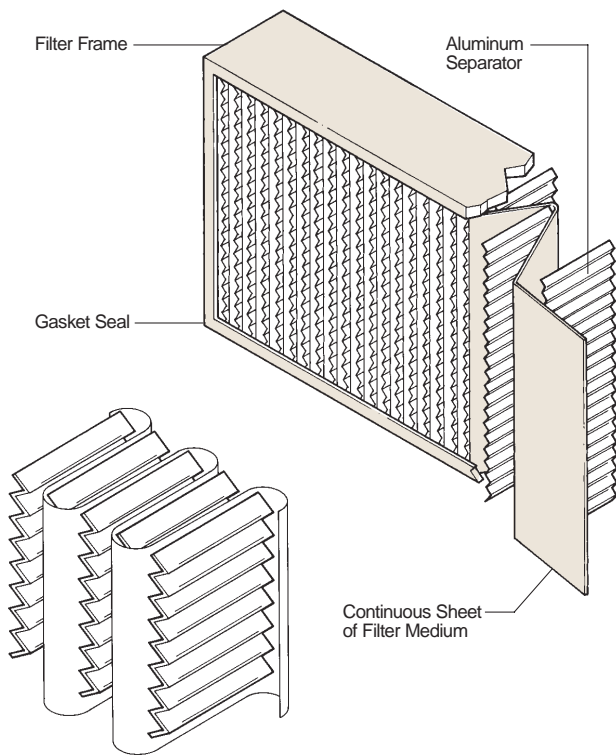

Figure 1. HEPA Details

HEPA filters retain particles by: sedimentation, electrostatic attraction, interception, inertial impaction and diffusion. Sedimentation occurs when particulate matter settles on the filter fiber because of gravity. Electrostatic attraction is the attraction of the particle to the filter fiber due to opposite electrical charges. Sedimentation and electrostatic attraction are the least efficient mechanisms of particle removal by HEPA filtration. Interception is dependent on particle size and occurs when a particle follows the air stream through the filter fibers, and is retained. Inertial impaction occurs when a large particle leaves the air stream to be impacted directly on the filter fiber. Diffusion occurs with very small particles, and is aided by the Brownian motion of the particle (Figure 2 and 3).

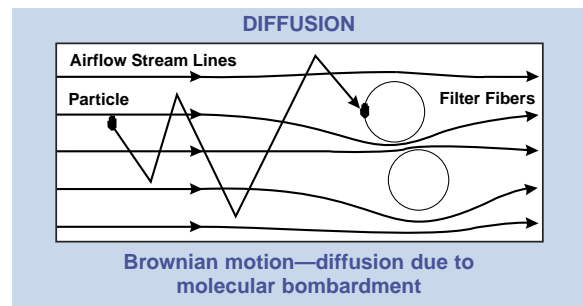
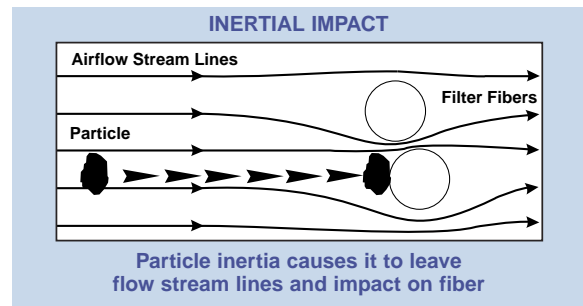
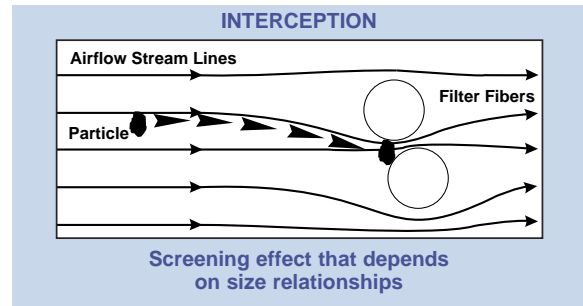

Figure 2. Air Filtration Theory: Particle Collection Mechanisms

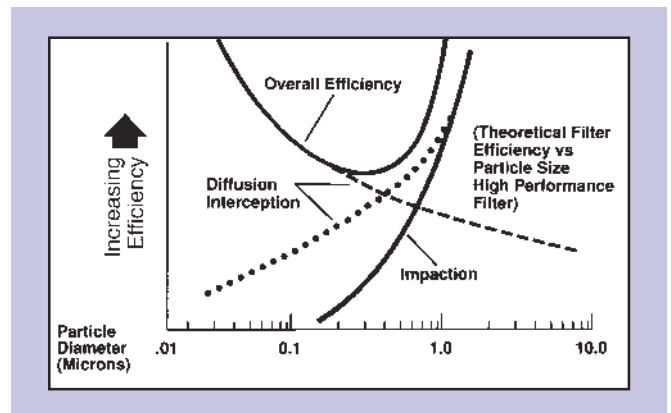

Figure 3. Relative Effect of Particle Collection Mechanisms

HEPA filters are rated on their ability to retain particles 0.3 micron ( $\mu\text{m}$ ) in size. The filters are commonly tested by injecting an aerosol of Dioctyl Phthalate (DOP) or similar liquid, which has a large number of 0.3  $\mu\text{m}$  droplets, into the upstream side of the filter during operation.

# Biological Safety Cabinets, Enclosures & Clean Benches

## OVERVIEW

Readings are taken on the opposite side of the filter to quantify the number of droplets that penetrate. Thus, if a filter allows one or fewer droplets to penetrate the filter with an initial concentration of 10,000, the filter is rated at 99.99 percent efficiency.

Because most aerosol droplets are larger or smaller than 0.3  $\mu\text{m}$ , the collection efficiency of a HEPA filter for these droplets is actually higher than its rating. Variations in filter efficiency, for example from 99.95 percent to 99.99 percent, are usually due to filter media or manufacturing techniques. While 99.95 percent filters are suitable for some appli-

cations, Labconco uses only 99.99 percent filters in all of its Purifier Biological Safety Cabinets, Enclosures and Clean Benches.

### **The Biosafety Levels**

The Centers for Disease Control (CDC) and the National Institutes of Health (NIH) have established Biosafety Levels 1 through 4. These four Biosafety Levels described below consist of combinations of laboratory practices and techniques, safety equipment and laboratory facilities. These Biosafety Levels are appropriate for the operations performed, the hazard posed by the infectious agents and for the laboratory function or activity.

**Biosafety Level 1** practices, safety equipment, and facility design and construction are appropriate for undergraduate and secondary educational training and teaching laboratories, and for other laboratories in which work is done with defined and characterized strains of viable microorganisms not known to cause disease in healthy adult humans. *Bacillus subtilis*, *Naegleria gruberi*, infectious canine hepatitis virus, and exempt organisms under the NIH Recombinant DNA Guidelines are representative of those microorganisms meeting these criteria. Many agents not ordinarily associated with disease processes in humans are, however, opportunistic pathogens and may cause infection in the young, the aged, and immunodeficient or immunosuppressed individuals. Vaccine strains that have undergone multiple *in vivo* passages should not be considered avirulent simply because they are vaccine strains.

Biosafety Level 1 represents a basic level of containment that relies on standard microbiological practices with no special primary or secondary barriers recommended, other than a sink for handwashing.

**Biosafety Level 2** practices, equipment, and facility design and construction are applicable to clinical, diagnostic, teaching and other laboratories in which work is done with the broad spectrum of indigenous moderate-risk agents that are present in the community and associated with human disease of varying severity. With good microbiological techniques, these agents can be used safely in activities conducted on the open bench, provided the potential for producing splashes or aerosols is low. Hepatitis B virus, HIV, the salmonellae, and *Toxoplasma* spp. are representative of microorganisms assigned to this containment level. Biosafety Level 2 is appropriate when work is done with any human-derived blood, body fluids, tissues, or primary human cell lines where the presence of an infectious agent may be unknown. (Laboratory personnel working with human-derived materials should refer to the OSHA *Bloodborne Pathogen Standard* for specific, required precautions.)

Primary hazards to personnel working with these agents relate to accidental percutaneous or mucous membrane exposures, or ingestion of infectious materials. Extreme caution should be taken with contaminated needles or sharp instruments. Even though organisms routinely manipulated at Biosafety Level 2 are not known to be transmissible by the aerosol route, procedures with aerosol or high splash potential that may increase the risk of such personnel exposure must be conducted in primary containment equipment, or in devices such as a Biological Safety Cabinet or safety centrifuge cups. Other primary barriers should be used as appropriate, such as splash shields, face protection, gowns, and gloves. Secondary barriers such as handwashing sinks and waste decontamination facilities must be available to reduce potential environmental contamination.

**Biosafety Level 3** practices, safety, equipment, and facility design and construction are applicable to clinical, diagnostic, teaching, research, or production facilities in which work is done with indigenous or exotic agents with a potential for respiratory transmission, and which may cause serious and potentially lethal infection. *Mycobacterium tuberculosis*, St. Louis encephalitis virus, and *Coxiella burnetii* are representative of microorganisms assigned to this level. Primary hazards to personnel working with these agents relate to autoinoculation, ingestion, and exposure to infectious aerosols.

At Biosafety Level 3, more emphasis is placed on primary and secondary barriers to protect personnel in contiguous areas, the community, and the environment from exposure to potentially infectious aerosols. For example, all laboratory manipulations should be performed in a Biological Safety Cabinet or other enclosed equipment, such as a gas-tight aerosol generation chamber. Secondary barriers for this level include controlled access to the laboratory and ventilation requirements that minimize the release of infectious aerosols from the laboratory.

**Biosafety Level 4** practices, safety equipment, and facility design and construction are applicable for work with dangerous and exotic agents that pose a high individual risk of life-threatening disease, which may be transmitted via the aerosol route and for which there is no available vaccine or therapy. Agents with a close or identical antigen relationship to Biosafety Level 4 agents also should be handled at this level. When sufficient data are obtained, work with these agents may continue at this level or at a lower level. Viruses such as Marburg or Congo-Crimean hemorrhagic fever are manipulated at Biosafety Level 4.

The primary hazards to personnel working with Biosafety Level 4 agents are respiratory exposure to infectious aerosols, mucous membrane or broken skin exposure to infectious droplets, and autoinoculation. All manipulations of potentially infectious diagnostic materials, isolates, and naturally or experimentally infected animals pose a high risk of exposure and infection to laboratory personnel, the community and the environment.

The laboratory worker's complete isolation of aerosolized infectious materials is accomplished primarily by working in a Class III Biological Safety Cabinet or a full-body, air-supplied positive-pressure personnel suit. The Biosafety Level 4 facility itself is generally a separate building or completely isolated zone with complex, specialized ventilation requirements and waste management systems to prevent release of viable agents to the environment.

From *Biosafety in Microbiology and Biomedical Laboratories*, U.S. Department of Health and Human Services, HHS publication (CDC) 99-8395, 4th ed. April 1999. Available for downloading from CDC's website at [www.cdc.gov](http://www.cdc.gov).

# Biological Safety Cabinets, Enclosures & Clean Benches

## OVERVIEW

### Biological Safety Cabinets—For Personnel, Product and Environment Protection

The term “Biological Safety Cabinet” (also Biosafety Cabinet) is widely used to describe a variety of containment devices equipped with HEPA filters, designed to provide personnel and environment protection, or personnel, product and environment protection from biohazardous material. The cabinets are defined by class, and again by type, based on their construction, airflow velocities and patterns, and by their exhaust system.

When using biohazard cabinets in conjunction with biohazardous material, toxins, or radionuclides, the operator and qualified safety officer must carefully assess the risk associated with any operation performed. Concentrations of toxins or radionuclides should not be allowed to reach levels which would interfere with the decontamination or servicing of the cabinet.

#### Class I Enclosure

The Class I enclosure is defined as a HEPA-filtered cabinet providing personnel and environment protection. Class I enclosures draw room air around the operator and through the work area, like a chemical fume hood, except that the exhaust air is passed through a HEPA filter. Class I enclosures may or may not be connected to an exhaust duct system. The Class I enclosure offers **Biosafety Level 1, 2 or 3 containment**; however, it only provides personnel and environment protection. There is no product protection from contaminants in the room air.

Class I enclosures operate with a typical average inflow or face velocity of 75-100 feet per minute (fpm). When operated at the higher velocity, and hard-ducted to an exhaust system, these cabinets can be used in conjunction with toxic chemicals or radionuclides. Despite their limitations, Class I enclosures can provide practical, economical containment solutions for users whose work is unaffected by room air. Such applications include handling suspicious mail, weighing powders, preparing media, asbestos manipulation, handling pollen or other allergens, and some microbiology procedures.

Labconco Class I enclosures include the Purifier Class I Safety Enclosure and Purifier HEPA Filtered Enclosure, both in 2- and 3-foot widths (Figure 4). Average inflow velocity is factory set to 90 fpm, but may

be modified to range between 75-100 fpm when the blower is adjusted by a qualified certification technician. Accessories for these enclosures include the Dished Epoxy Work Surface, Adjustable Height Base Stand, Exhaust Connection Kit and Remote Blower. See the Selection Guide on pages 8 and 9.

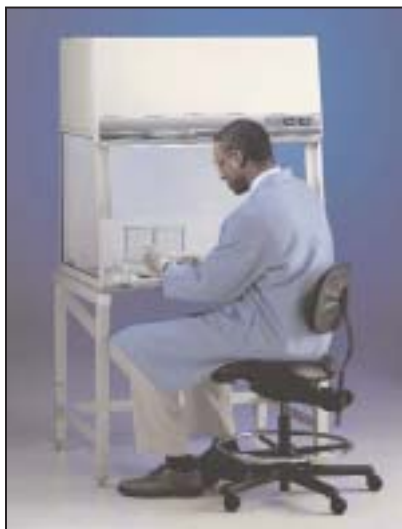

Figure 4. The Purifier HEPA Filtered Enclosure may be used as a balance enclosure for weighing powders.

#### The Class II Cabinet

The Class II cabinet is defined as a ventilated cabinet for personnel, product and environment protection. It has an open front with inward airflow for personnel protection, HEPA-filtered laminar airflow for product protection, and HEPA-filtered exhaust air for environment protection. Class II cabinets are suitable for use with agents that require **Biosafety Level 1, 2 or 3 containment**.

*When toxic chemicals or radionuclides are used as adjuncts to biological studies or pharmaceutical work, Class II cabinets designed and constructed for this purpose should be used.*

#### The Class III Cabinet

The Class III cabinet is defined as a totally enclosed, ventilated cabinet of gas-tight construction. Operations in the cabinet are conducted through attached rubber gloves. The cabinet is maintained under negative air pressure of at least 0.5 inch (12.7mm) water gauge (w.g.). Supply air is drawn into the cabinet through HEPA filters. The exhaust air is treated by double HEPA filtration, or by HEPA filtration and incineration. Class III cabinets are suitable for work with agents that require **Biosafety Level 1, 2, 3 or 4 containment**. Class III cabinets are not offered in this catalog.

### Types of Class II Cabinets

NSF International\*, as part of its NSF Standard 49 for Class II biosafety cabinets, provides Type designations that further delineate the various cabinets based on airflow characteristics. NSF International periodically reviews and changes the Standard as needed and, in 2002, updated its Type designations as described below.

#### Type A1 (formerly Type A)

Cabinets that: (1) maintain minimum calculated average inflow velocity of 75 fpm through the work area access opening; (2) have HEPA filtered downflow air from a common plenum (i.e. plenum from which a portion of the air is exhausted from the cabinet and the remainder supplied to the work area); (3) may exhaust HEPA filtered air back into the laboratory or canopy-ducted to the outside; and (4) may have positive pressure contaminated ducts and plenums not surrounded by negative pressure plenums. Type A1 cabinets are suitable for work with biological agents in the absence of volatile toxic chemicals or radionuclides. Labconco does not offer Class II, Type A1 cabinets. Instead, we recommend the Purifier Delta Series Class II, Type A2 Safety Cabinet.

#### Type A2 (formerly Type A/B3)

Cabinets that: (1) maintain a minimum (calculated or measured) average inflow velocity of 100 fpm through the work area access opening; (2) have HEPA filtered downflow air that is a portion of the mixed downflow and inflow air from a common exhaust plenum; (3) discharge all exhaust air to the atmosphere after HEPA filtration; and (4) have all biologically contaminated ducts and plenums under negative pressure or surrounded by negative pressure ducts and plenums. Type A2 cabinets are suitable for work with biological agents treated with minute quantities of volatile toxic chemicals and tracer quantities of radionuclides that will not interfere with the work if recirculated in the downflow air.

Labconco offers Purifier Delta Series Class II, Type A2 Safety Cabinets in 3-, 4- and 6-foot widths. Access opening face velocity is a nominal 105 fpm. With the addition of the Canopy Kit and remote blower, the Purifier Delta Series Class II Safety Cabinet may be thimble-ducted to the outside. See the Selection Guide on pages 8 and 9.

\*See page 4 for more information on NSF International and Standard 49.

# Biological Safety Cabinets, Enclosures & Clean Benches

## OVERVIEW

### Type B1

Cabinets that: (1) maintain a minimum (calculated or measured) average inflow velocity of 100 fpm through the work area access opening; (2) have HEPA filtered downflow air composed largely of uncontaminated recirculated inflow air; (3) exhaust most of the contaminated downflow air through a dedicated duct exhausted to the atmosphere after passing through a HEPA filter; and (4) have all biologically contaminated ducts and plenums under negative pressure or surrounded by negative pressure ducts and plenums. Type B1 cabinets may be used with biological agents treated with minute quantities of toxic chemicals and tracer amounts of radionuclides required as an adjunct to microbiological studies if work is done in the direct exhausted portion of the cabinet, or if the chemicals or radionuclides will not interfere with the work if recirculated in the downflow air. While the Type B1 cabinet allows limited use with toxic chemicals, it recirculates approximately 30 percent of the contaminated work area air through the supply HEPA filter.

Labconco does not offer a Type B1 Cabinet. Instead, we recommend either the Purifier Delta Series Total Exhaust (Class II, Type B2) Cabinet, which exhausts 100 percent of its air, or the Purifier Delta Series Class II, Type A2 Cabinet, which exhausts 30 percent.

### Type B2

Sometimes referred to as "Total Exhaust," these are cabinets that: (1) maintain a minimum (calculated or measured) average inflow velocity of 100 fpm through the work area access opening; (2) have HEPA filtered downflow air drawn from the laboratory or outside air; (3) exhaust all inflow and downflow air to the atmosphere after filtration through a HEPA filter without recirculation into the cabinet or return to the laboratory room air; and (4) have all contaminated ducts and plenums under negative pressure, or surrounded by directly exhausted negative pressure ducts and plenums. Type B2 cabinets may be used with biological agents treated with toxic chemicals and radionuclides required as an adjunct to microbiological studies.

Labconco manufactures Purifier Delta Series Total Exhaust Cabinets in 4- and 6-foot widths. Remote blowers and ductwork are required and offered as accessories. See the Selection Guide on pages 8 and 9.

### Biological Challenge Testing

Biological challenge testing of biological safety cabinets is the ultimate measure of the cabinet's ability to perform its intended function—to contain biohazardous aerosols. In the challenges, aerosol suspensions of *Bacillus subtilis* spores are used to quantify the ability of the cabinet to contain biohazardous aerosols (Figure 5).

The challenge consists of three separate tests:

- The Personnel Protection Test measures the ability of the cabinet to prevent the escape of the aerosol into the outside environment.
- The Product Protection Test measures the ability of the cabinet to prevent aerosols from entering the interior of the cabinet.
- The Cross Contamination Protection Test measures the ability of the cabinet to contain aerosols in different regions of the cabinet work area.

### NSF Standard Number 49

NSF International (formerly the National Sanitation Foundation) is an independent, non-profit organization. NSF acts as a neutral agency,



Figure 5. A Labconco engineer sets up equipment in a Purifier Delta Series Class II Cabinet to conduct a biological challenge test.

servicing the consumer, government and industry in developing solutions for problems pertaining to public health and the environment.

In response to user and industry requests, NSF International, with the cooperation of government, consumers, certifiers, and leading manufacturers, developed NSF Standard 49, which establishes minimum construction and performance standards for Class II Biohazard Cabinets. Standard 49 also establishes the tests which the manufacturer must perform on every cabinet built. To ensure compliance, NSF performs periodic unannounced audits of the manufacturer's assembly locations and sets requirements for retesting.



Domestic Labconco Purifiers are built to meet or exceed the minimum requirements of NSF Standard 49 and bear the NSF mark. Visit [www.nsf.org/certified/Biohazard/](http://www.nsf.org/certified/Biohazard/) for a current roster of all NSF-Listed biological safety cabinets.

### ETL Electrical Safety Listings



ETL Testing Laboratories, originally organized by the Edison Illuminating Companies, has been conducting electrical performance and reliability tests since 1896.

Intertek Testing Services (ITS), which acquired ETL Testing Laboratories from Inchcape in 1996, is recognized by OSHA as a Nationally Recognized Testing Laboratory (NRTL) just as Underwriters Laboratories (UL), Canadian Standards Association (CSA) and several other independent organizations are recognized. A federal law passed in 1988 established the NRTL program to eliminate provisions that explicitly required or implied that product certification be performed only by standard-writing companies such as UL. Since each NRTL must meet the same OSHA requirements of competency, NRTLs recognized for the same product safety test standard are considered as equivalent in their capability to certify to that standard. This program has allowed competing organizations, such as ETL, into this previously exclusive certification arena and given manufacturers options and bargaining power to drive competitive costs and delivery. ITS uses the ETL mark to signify that a product conforms to UL Standard 3101-1 in the U.S. and the CAN/CSA Standard C22.2 No. 1010.1 in Canada. Products that bear the ETL mark, such as the Purifier line of safety cabinets, enclosures and clean benches, are subjected to a comprehensive safety program that includes testing, listing, labeling and quarterly follow-up inspections. For a current list of Labconco products bearing the ETL mark, visit [www.etlsemko.com](http://www.etlsemko.com).

# Biological Safety Cabinets, Enclosures & Clean Benches

## OVERVIEW

### CE Marking



The CE mark indicates the product conforms to all safety and other directives/specifications presently required by the Council of European Communities. The CE mark was established in 1993 to standardize European countries' electrical directives into a single set of regulations, eliminating barriers to trade. Present rules require that products meet electrical safety requirements set for laboratory equipment and also pass rigorous electromagnetic emissions testing (interference signals being output by the product) and electromagnetic immunity testing (the product should not respond to outside electromagnetic interference signals).

### Certification and Decontamination

Before each Purifier Delta Series Safety Cabinet is shipped to a customer, Labconco technicians assure its performance by conducting a series of tests including filter integrity testing, setting the damper and motor speed, and verifying the airflow (Figure 6). Upon delivery and installation of a cabinet at the customer's facility, certification plays a critical role in a cabinet's performance. Certification should be performed by an independent certifier, at least annually, and whenever the cabinet is moved or serviced. An initial certification ensures that no damage occurred while the cabinet was transported. Annual certifications provide verification that performance levels remain satisfactory. A typical certification includes: leak testing of the HEPA filter(s), establishing the proper air velocities and flow patterns in the cabinet, and testing the light level and electrical circuits of the cabinet.

Because biological safety cabinets are often used in research involving biohazardous materials, they are usually decontaminated with gaseous formaldehyde before servicing the interior components of the cabinet. Surface decontamination of biohazard cabinets is usually accomplished by using a 70 percent ethanol solution, or an appropriate disinfectant which is compatible with the materials used in the cabinet. Surface decontamination should be performed routinely before and after using the cabinet.

### Special Applications for Biological Safety Cabinets

#### Handling Suspicious Mail

Bioterrorism involving mail potentially contaminated with biohazards such as anthrax and smallpox has created demand for enclosures where suspicious mail can be safely sorted and opened. The Centers for Disease Control and Prevention (CDC) recommends handling anthrax and smallpox using Biosafety Level 2 practices, containment equipment and facilities. The Biosafety Level 2 recommendation is required for work on a laboratory scale, which would be similar to the small amounts of infected agents found in dangerous mail. Class I enclosures, such as Purifier Class I Safety Enclosures and Purifier HEPA Filtered Enclosures, are Biosafety Level 2 equipment that provide the necessary personnel protection without providing unneeded product protection. Class I enclosures, like any laboratory device, have the potential of misuse by persons unfamiliar with biological safety cabinets or common laboratory practices such as aseptic technique. Training of personnel is essential and the risk of misuse must be weighed against the potential for exposure to biohazards. Consult your safety officer for recommendations based on your specific application.



Figure 6. Prior to shipment, the proper airflow in the Purifier Delta Series Cabinet is verified.

### Working with HIV

The CDC and the National Institutes of Health (NIH), in an addendum to their publication, *Biosafety in Microbiology and Biomedical Laboratories*, stated that HIV should be included in Biosafety Levels 2 and 3. The Levels are dependent on the concentration or quantity of virus or the type of laboratory procedure used. Labconco offers Purifier Class I Safety Enclosures, Purifier HEPA Filtered Enclosures, Purifier Class II, Type A2 Safety Cabinets, and Purifier Total Exhaust Safety Cabinets, all of which are suitable for Biosafety Level 2 and 3 agents. Consult your safety officer for recommendations based on your specific application.



Figure 7. Purifier Delta Series Class II Safety Cabinets may be outfitted with an IV Bar for preparing cytotoxic or hazardous drugs.

### Handling cytotoxic or hazardous drugs

Many drugs currently in use may be oncogenic, mutagenic, or exert any number of toxic side-effects on health care professionals exposed to them. Aerosols or chemical dusts are often generated during routine handling and preparation of these hazardous drugs.

The American Society of Health-System Pharmacists (ASHP) recommends, as a minimum measure, that work involving hazardous drugs be performed in a Class II, Type A1 or A2 Cabinet (Figure 7). The selection of a hard-ducted Type B2 cabinet is preferable. For current ASHP guidelines, visit [www.ashp.org](http://www.ashp.org).

# Biological Safety Cabinets, Enclosures & Clean Benches

## OVERVIEW

### Clean Bench—For Product Protection Only

The clean bench is a device that uses a blower to force room air through a HEPA filter, and into a work area. The filtered air may be directed vertically or horizontally over the work surface (Figure 8).

Clean benches were developed as part of “clean room” technology and are widely used in the electronics and pharmaceutical industries. They are also frequently used in research laboratories for tissue culture and media preparation, and in hospitals and pharmacies for syringe filling and parenteral drug formulation.

The major limitation of clean benches is that they only provide product protection; no effort is made to control aerosols generated in the work area. The operator is constantly exposed to any aerosols generated by the work being performed.

Clean benches should never be used in conjunction with biohazardous materials, toxins or radionuclides. The operator and a qualified safety officer must carefully assess the risk associated with any operation performed in a clean bench.

Accessories commonly used in the clean bench include fluorescent lighting, prefilters, electrical outlets, service fixtures, UV lights, and bars for hanging intravenous bags.

Labconco offers Purifier Horizontal Clean Benches in 3-, 4- and 6-foot widths and Purifier Vertical Clean Benches in 2- and 3-foot widths. The Purifier PCR Enclosure is a type of vertical clean bench designed to

offer a controlled environment in which to perform polymerase chain reaction experiments. The Purifier PCR Enclosure, available in 2- and 3-foot widths, includes an ultraviolet lamp with 5-minute timer so that between uses, any DNA or RNA present in the work area can be deactivated by the UV light.

In addition, Labconco offers three 3-foot PVC total exhaust clean benches: the Purifier Forensic Enclosure, Purifier Trace Metals Work Station and Purifier Class 100 Chemical Station. These enclosures function like a combination vertical clean bench and light duty fume hood. HEPA-filtered air is projected downward through the work area to provide product protection while the operator is protected from fumes and vapors generated in the work area by the inflow of air through the face of the clean bench. The inflow of air through the face passes under the work surface and is exhausted to the outside so that it does not contaminate the work area. At the same time, all of the HEPA-filtered air is also exhausted to the outside.

The interior of these total exhaust clean benches is constructed of non-metallic, corrosion-resistant components making them ideal for applications such as non-biohazardous crime evidence handling or trace metal analysis of environmental samples. Since they exhaust to the outside, they may be used for applications such as handling malodorous particulate-sensitive materials or solvent-based cleaning of electronic components. Remote blower and ductwork are required and sold separately. See the full line of Purifier Clean Benches in the Selection Guide on pages 10 and 11.

Side Views

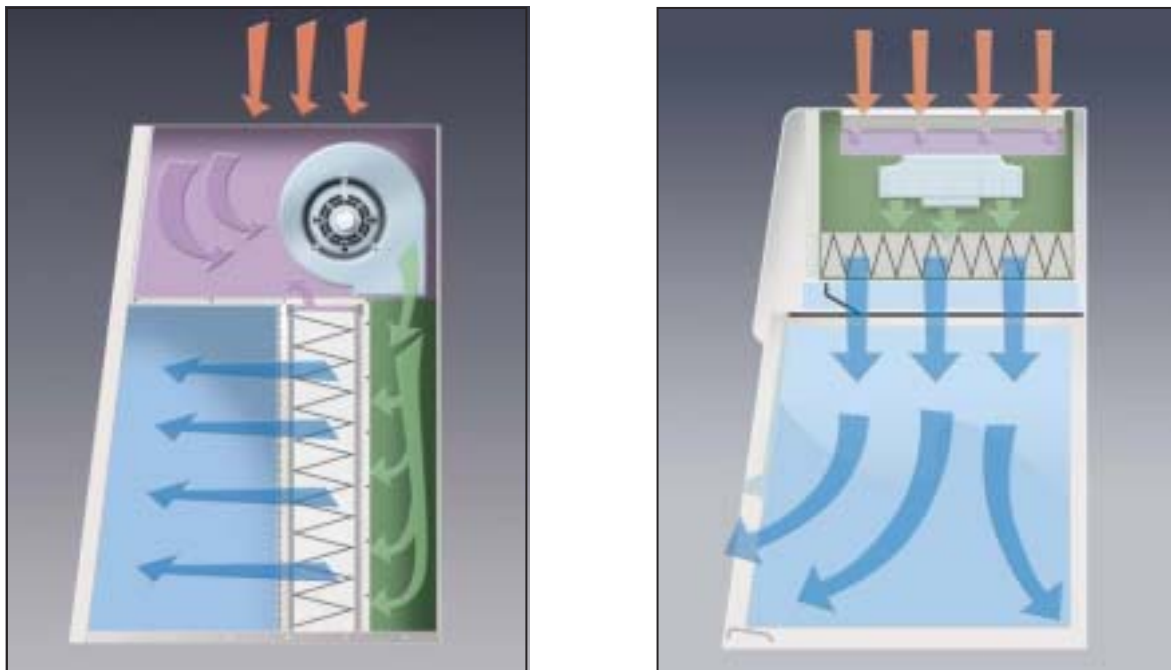

Figure 8. Horizontal Clean Bench (left) and Vertical Clean Bench (right)



# Biological Safety Cabinets, Enclosures & Clean Benches

## OVERVIEW



Figure 9. Clean benches provide Class 100 conditions for testing electronic components.

### Selecting a Class I Enclosure, Biological Safety Cabinet or Clean Bench

#### Primary Consideration—Safety

Selecting the proper work station depends largely on its application:

- 1) the type of protection required
  - a. product protection only
  - b. personnel and environment protection only
  - c. personnel, product and environment protection
- 2) the different types of work — present and future — that will be done in the cabinet
- 3) the types and quantities of toxic materials that will be used in the course of the work
- 4) the type of exhaust system that will be needed.

Items 1, 2 and 3 are determined by the user of the cabinet, based on individual needs. Item 4 will be determined by the first three. Biological containment is not an issue when selecting among Class I enclosures and biological safety cabinets because ALL Class I and Class II cabinets are designed for Biosafety Levels 1, 2 and 3 containment.

If after careful consideration of present and future applications, it is determined that only product protection is required and that the work does not involve biohazardous or toxic materials, then a clean bench may be the work station of choice.

#### Secondary Consideration—Cost

Understanding the costs involved in owning and operating a biosafety cabinet or Class I enclosure is important. Capital expenditures include the cabinet itself and a base stand if required. Type B2 cabinets, some Class I enclosures and total exhaust clean benches, which are ducted to the outside, also require ductwork, remote blowers and dampers for operation. Cost outlays include installation of the cabinet, the exhaust system and its blower, and initial certification. Operating and maintenance expenses include heating or air conditioning losses, electrical power consumed, prefilter and HEPA filter replacement, and the annual recertification charges.

The costs for a clean bench include the bench itself, its base stand, a work surface if not included and initial certification. Installation outlays are generally less expensive than the biosafety cabinet but should be considered. Finally, operating expenses include electrical power consumed, prefilter and HEPA filter replacement, and the annual recertification expenses.

#### Tertiary Consideration—Options

Many options and accessories are available that customize a Class II biosafety cabinet, Class I enclosure or clean bench to the user's needs. Purifier Delta Series Class II, Type A2 Cabinets and Purifier Horizontal Clean Benches come in 3-, 4- and 6-foot widths. Purifier Delta Series Class II, Type B2 Total Exhaust Cabinets come in 4- and 6-foot widths. Purifier Class I, HEPA Filtered and PCR Enclosures and Purifier Vertical Clean Benches come in 2- and 3-foot widths. If the user is confused about which size is needed, it is useful to mark a section of laboratory benchtop space equal to the dimensions of the cabinet's interior. The researcher should then perform several "dry runs" of his/her work within the marked area, to see if it is large enough.

Service fixtures are accessories that many researchers prefer to have on their cabinets. The valves, which should be easily accessible to the operator, may provide vacuum, air, gases or water. Purifier Delta Series Safety Cabinets and Purifier Horizontal Clean Benches are available with factory-installed service fixtures or Service Fixture Kits may be field-installed later as needs change. The Purifier Trace Metals Enclosure, Forensic Enclosure and Class 100 Work Station are not designed for service fixtures. The remaining Purifier Enclosures do not have service fixtures but have open bottoms to allow placement over a counter-mounted fixture if necessary.

Ultraviolet (UV) lamps are often installed in a Class II biosafety cabinet, Class I enclosure or clean bench as an aid in decontamination of the work area. The lamps are similar in construction to fluorescent lights, except they emit ultraviolet light with a wavelength of 254 nanometers (nm). This wavelength of light is disruptive to DNA molecules, resulting in a broad spectrum disinfection. While UV light is effective when it strikes a microbial cell directly, it is ineffective when the cell is protected by dust, dirt, or organic matter. UV irradiation of the work area should only be used as a secondary method of maintaining the disinfected status of the cabinet; it should never be relied on alone to disinfect a contaminated work area. Ultraviolet irradiation is damaging to the eyes and skin, and the UV lamp should never be on when using the cabinet. Purifier Delta Series Safety Cabinets, Class I Safety Enclosures, Clean Benches and PCR Enclosures are available with factory-installed UV lamps.

An IV (intravenous) bar is useful in many clinical and pharmaceutical applications. Users may hang IV bottles or bags from the bar during drug preparation. The bar disrupts the airflow patterns in its area, so the user must ensure that for biosafety cabinets, the cabinet has been certified to NSF Standard 49 with the bar in place. IV Bar Kits are available for Purifier Delta Series Safety Cabinets and Clean Benches.



All Purifier products are benchtop design, therefore an accessory base stand or supporting bench is necessary. For Class II safety cabinets, the base stand must pass NSF Standard 49 stability tests with the cabinet attached in order to be used with the cabinet.

The Selection Guide that follows on pages 8-11 summarizes the choices Labconco offers.

# Biological Safety Cabinets, Enclosures & Clean Benches

## SELECTION GUIDE

The Selection Guide below and on pages 8 and 9 provides at-a-glance descriptions of the protection provided, airflow characteristics, options and applications for Labconco HEPA-filtered Class II safety cabinets, Class I enclosures and clean benches. In most cases, more than one HEPA-filtered product may be suitable for any given application. In other cases, when your application involves both hazardous vapors/fumes and non-biohazardous

<b>Description</b> <b>Product</b>	 <b>Class II, Type A2</b> <b>Purifier Delta Series Class II, Type A2 Safety Cabinet</b> See pages 18-24	 <b>Class II, Type A2 with Canopy</b> <b>Purifier Delta Series Class II, Type A2 Safety Cabinet</b> See pages 18-25
<b>Protection Provided</b> Product Only Personnel and Environment Only Personnel, Product and Environment		
<b>Suitable For Use With:</b> Biosafety Level 1, 2 and 3 Agents Objectionable Odors Toxic Particulates Volatile Toxic Chemicals Tracer Quantities of Radionuclides	● ● ●	● ● ● ● ●
<b>Airflows &amp; Exhaust System</b> Exhausts to: Exhaust Duct Connection Ganged Exhaust System Possible Dedicated Exhaust System Required % Recirculation In Cabinet	Room None  ≈70	Outside Canopy  ≈70
<b>Options/Accessories</b> Service Fixtures UV Light IV Bar Work Surface Adjustable Height Base Stand Seismic Base Stand Vibration Isolation Table Remote Blower	● ● ● Included ● ● ●	● ● ● Included ● ● ●
<b>Biotechnology</b> Sterile Media Preparation Non-biohazardous Culture Maintenance Culture Maintenance Non-biohazardous Tissue Culture Maintenance Tissue Culture Maintenance Plant Tissue Culture Maintenance Blood Component Research Human Tissue Research PCR	● ● ● ● ● ● ● ● ●	● ● ● ● ● ● ● ● ●
<b>Microbiology</b> Sterile Media Preparation Non-biohazardous Culture Maintenance Culture Maintenance Work with Malodorous Cultures Non-biohazardous Tissue Culture Maintenance Tissue Culture Maintenance Isolation of Clinical Specimens Blood Testing/Analysis QA Procedures/Testing Non-volatile, Non-toxic Staining Staining with Volatile, Toxic Material Non-volatile Radiolabeling/Tagging Volatile Radiolabeling/Tagging	● ● ● ● ● ● ● ● ● ● ● ● ● ● ●	● ● ● ● ● ● ● ● ● ● ● ● ● ● ●
<b>Pharmacy</b> Non-toxic IV Solution Preparation Antineoplastic Drug Preparation Radionuclide Preparation	● ● ●	● ● ●
<b>General</b> Tissue Fixation/Staining Preparation Weighing Toxic Powders General Forensics Trace Metals Analysis Asbestos Handling Suspicious Mail Handling QA/QC Testing Electronics Inspection/Repair Soldering	● ● ● ● ● ● ● ● ● ● ●	● ● ● ● ● ● ● ● ● ● ●







# Biological Safety Cabinets, Enclosures & Clean Benches

## SELECTION GUIDE

particulates, other Labconco ventilation products not mentioned in this catalog, such as the Paramount® Filtered Enclosure or Protector® Multi-Hazard Glove Box, may be more appropriate. For help determining which safety cabinet, enclosure, clean bench or other ventilation product is best suited for your specific combination of applications, contact a Labconco specialist at 800-821-5525, 816-333-8811 or labconco@labconco.com.

<b>Vertical Clean Bench</b> Purifier PCR Enclosure See pages 44-47	 Purifier Vertical Clean Bench See pages 48-51	 <b>Horizontal Clean Benches</b> Purifier Horizontal Clean Bench See pages 52-56
•	•	•
•	•	•
Room None	Room None	Room None
Not Applicable	Not Applicable	Not Applicable
With Timer • • •	• • • •	• • • • •
PCR Enclosures and Vertical Clean Benches have been redesigned and eliminated from this pdf document. See the Purifier Vertical Clean Benches, PCR Enclosures & Tissue Culture Enclosures brochure for current information.	• •	• • • •
	•	•
	•	•
	•	•
	•	•
•	•	•
•	•	•



# △ Purifier® Delta® Series Class II Biological Safety Cabinets

## OVERVIEW

### Delta® Series Delivers Safety

The most compelling reason to choose a Purifier Delta Series Class II Cabinet is safety. You simply won't find another biohazard cabinet with a more comprehensive safety package.

Bright color signifies danger and key components are epoxy-coated orange to provide a visual reminder to work safely in these areas. One such area is the exclusive sash pocket. Located behind the front panel, the sash pocket encases the sash as it is raised, shielding the user and environment from exposure to any potential contamination on the interior side of the sash. The pocket provides an added dimension of safety to other measures such as 99.99% efficient HEPA-filtered laminar flow and negative pressure plenum design.

Unseen, but remarkable, is the unitized, stainless steel frame. The substructure provides a more stable and accurate foundation than multi-piece designs so potential for leaks is minimized. Other safety features, such as the sash, just can't be missed. The sash provides tactile feedback to the operator to not lift it beyond its working height while the cabinet is in use. Raising the sash beyond this point triggers an audible/visual alarm. The sash may also be fully closed to prevent contaminants from entering or leaving the cabinet during UV disinfection or non-use.

### Safety Features

- Fully closing tempered safety glass sash with audible/visual alarm indicator
- △ • Sash pocket keeps potential contamination contained
- △ • Curved air foil
- △ • Tactile indication when sash is raised to its optimum operating level
  - Interlocked UV light only operates when blower and fluorescent light are off and sash is closed
- △ • Minihelic\* II pressure gauge mounted inside the work area so that potential leaks around the gauge are forced through a HEPA filter before exhausting to the environment
  - Electrical duplex receptacles with ground fault interruption
- △ • Safety color-coded towel catch, sash pocket and exhaust cap
  - 99.99% efficient HEPA filters
  - Unitized 16 gauge stainless steel structure
  - Intrinsically-safe negative pressure design
  - 115 volt, 60 Hz models are NSF International Listed
- △ • Safety color-coded air foil available



The towel catch prevents wipes and other lightweight items from being drawn into the cabinet's internal cavity where they could damage components and alter airflow.



The curved air foil prevents the potentially dangerous practice of placing materials in this area.



The vertical-rising sash can be completely closed when not in use, providing a physical barrier.



The sash pocket shields the sash as it is raised so that potential contamination is not spread to upper cabinet areas.

◀ Purifier Delta Series Class II, Type A2 Safety Cabinet 3620404 on Manual Hydraulic Lift Stand 3780200 with Caster Kit 3784000 and Ergonomic Chair 3744000.

\*Minihelic® II is a registered trademark of Dwyer Instruments Incorporated.

△ Exclusive feature

# Purifier® Delta® Series Class II Biological Safety Cabinets

## OVERVIEW



The Air-Wave™ Entry System, featuring aerodynamic angles surrounding the access opening, provides less airflow resistance for better containment.

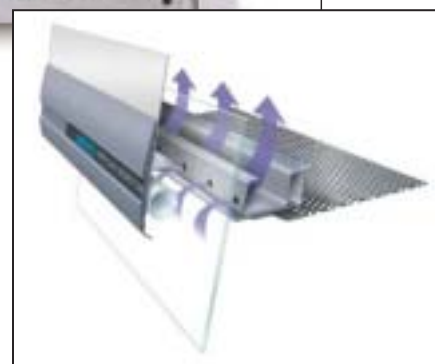

Contain-Air™ Negative Pressure Channel draws air in, preventing loss of containment at the top of the sash.



Reserve-Air™ Secondary Airflow Slots, located in front of the air foil's inflow grille, draw air into the Purifier should the operator inadvertently block the grille area. Safe airflow is always maintained.

# △ Purifier® Delta® Series Class II Biological Safety Cabinets

## O V E R V I E W

### Delta® Series Delivers Performance

Every component of the Purifier Delta Series Cabinet has been optimized for peak performance. The Air-Wave™ Entry System, consisting of the curved design of the side posts, air foil and sash handle, ensures smoother airflow into the work area minimizing turbulence and enhancing containment. Internally, we've designed a ramped steel plenum that captures the inflow air, stabilizes it, and then distributes it evenly across the HEPA filters and the work area. Laminar airflow is idealized and *true*, not zoned. The Air-Wave Entry System and plenum work together to provide superior airflow that protects the operator and prevents cross contamination.

The exclusive Contain-Air™ Negative Pressure Channel, located behind the sash, maximizes containment at the air gap between the top of the sash opening and the cabinet wall. Any hazardous aerosol created in the work area that may travel upward toward the sash is drawn into the channel by negative pressure and then forced through a HEPA filter. Unreliable seals and gaskets, which could degrade or drag on the contaminated glass, are not used.



*The sash is counterweighted for balance, greater reliability and durability. The anti-racking mechanism ensures easy raising and lowering from all areas of the sash handle.*

### Performance Features

- △ • Air-Wave™ Entry System
- △ • Ramped steel plenum for *true* laminar airflow
  - 105 fpm nominal face velocity
- △ • Perforated exhaust filter cap for balanced exhaust airflow
- △ • Sure-Start™ voltage-compensating speed control with 40 amp capacity and electronic adjustability
  - Counterweighted sliding sash with anti-racking mechanism
  - Single switch fluorescent light and blower start up
- △ • Contain-Air™ Negative Pressure Channel at the top of the access opening
- △ • Reserve-Air™ Secondary Airflow Slots
  - Low clearance design requires only 6" clearance from ceiling
  - ISO Class 5 air (formerly Class 100) in the work area



*Controls for the blower, fluorescent light and UV light are consolidated into a single switch ensuring safe operation.*

△ Exclusive feature

# Purifier® Delta® Series Class II Biological Safety Cabinets

## OVERVIEW

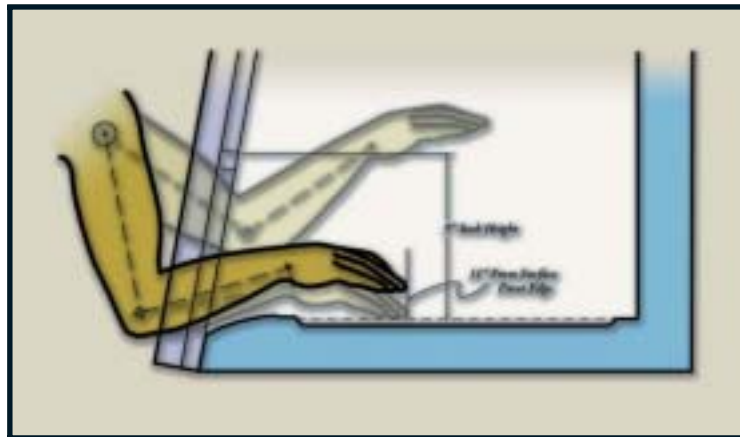
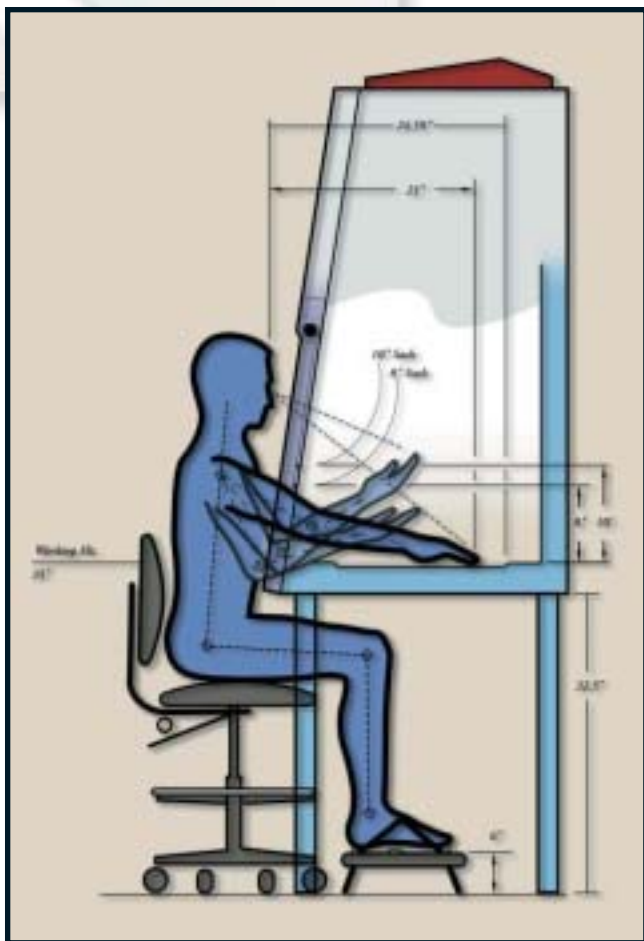

The radiused air foil provides a comfortable surface for forearms resting on it, reducing fatigue.

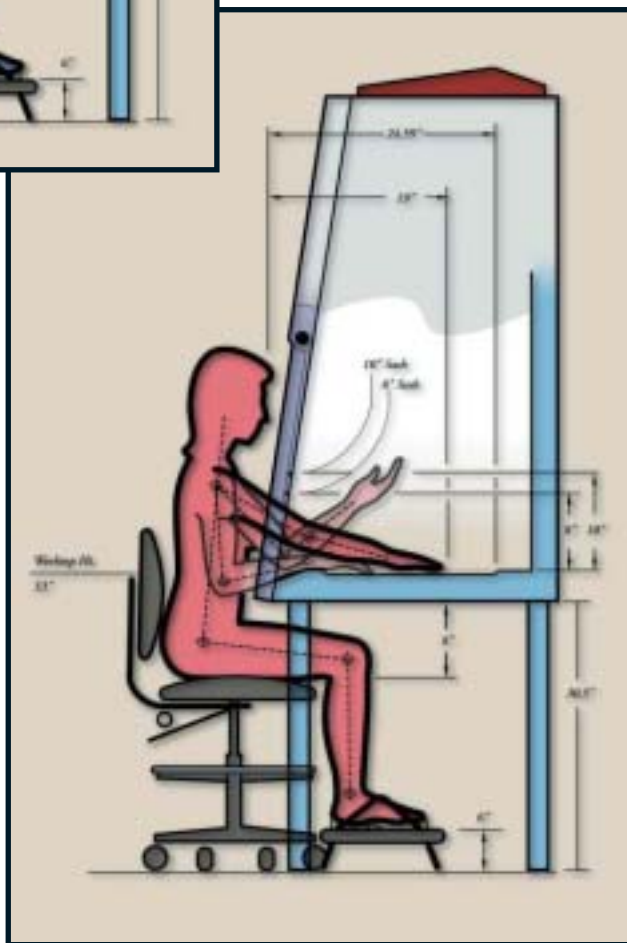

The Purifier Delta Series Safety Cabinet was designed to provide a safe and effective work area for both men and women. Ergonomic principles were applied to ensure that humans of all sizes maintain a healthy posture, and have good visibility and range of motion while safely using the cabinet. The illustrations at left show an adult male of an average height of 5' 9.1" and an adult female of an average height of 5' 3". The accessory base stand, chair and footrest work together to achieve the proper height for individuals using the cabinet.

# △ Purifier® Delta® Series Class II Biological Safety Cabinets

## OVERVIEW

### Delta® Series Delivers Ergonomics

Because fatigue increases the risk of accidents and personal injury, we designed the Purifier Delta Series Cabinet to be comfortable and convenient to use. With assistance from human factors specialists, Labconco engineers created dimensions for the cabinet that fit people of all sizes. The monitors and controls are within easy sight and reach—exactly where they should be. The Minihelic II pressure gauge is located in the user's field of vision to allow continuous monitoring of safe operating parameters. The switches and alarm indicators are mounted low to meet ADA\* requirements and to reduce eye strain. The curved air foil has no pronounced edges so arms may rest comfortably.

The inclined sash and front panel offer ergonomic benefits as well as an attractive exterior. The front panel above the sash is free of protrusions that could interfere with visibility or obstruct taller users. More importantly, the sash is angled for closer, more comfortable viewing without glare.

A spacious interior adds to the cabinet's functionality. The service fixtures are mounted 9" above the work surface to maximize usable surface space. They are mounted close to the front within easy reach of the user. The seamless one-piece dished work surface has smooth, radiused edges for easy cleaning.

### Ergonomic Features

- △ • Most spacious interior in the industry
- △ • Eye-level Minihelic II pressure gauge
- △ • ADA-compliant controls, switches and electrical receptacles
- △ • Radiused air foil
  - Inclined, sliding sash
- △ • Low profile front panel
  - Service fixtures mounted 9" above the work surface
  - Removable dished work surface is smooth and non-welded
  - ADA-compliant adjustable height accessory base stand
  - Accessory chair and footrest

△ Exclusive feature

\*Americans with Disabilities Act



The Minihelic II pressure gauge has a large dial for easy readability and is located in the user's direct field of vision.



Service fixtures are mounted within reach of the operator but somewhat higher so that they are less likely to snag on clothing or bump the user's forearms.



Interior offers the most cubic feet of area in the industry.



Controls are mounted in the user's field of vision to limit neck movement and meet ADA requirements.







# Purifier® Delta® Series Class II, Type A2 Safety Cabinets

## INTRODUCTION

The Purifier Delta Series Class II, Type A2 Safety Cabinet protects you, your work and your laboratory environment. Typical applications include work with agents that require Biosafety Level 1, 2 or 3 containment, and antineoplastic drug preparation.

This cabinet may discharge HEPA-filtered exhaust air directly into the laboratory, or into an exhaust system through the optional Canopy Connection Kit. When canopy-connected, the Purifier Delta Series Cabinet may be used for applications involving minute quantities of volatile toxic chemicals and tracer amounts of radionuclides required as an adjunct to microbiological research.

During operation, room air is drawn into the grille located in the air foil located in the air foil. The air in the plenum beneath the work surface is a mixture of unfiltered room air, and air that has just passed through the work area. This contaminated air is drawn by the blower through the back plenum of the cabinet, where approximately 70% of the air is recirculated through the supply HEPA filter and back over the work area. The balance of the contaminated air is discharged to the environment after passing through the exhaust HEPA filter.

-  Room Air
-  HEPA-Filtered Air
-  Unfiltered Air under Negative Pressure
-  Unfiltered Air under Positive Pressure

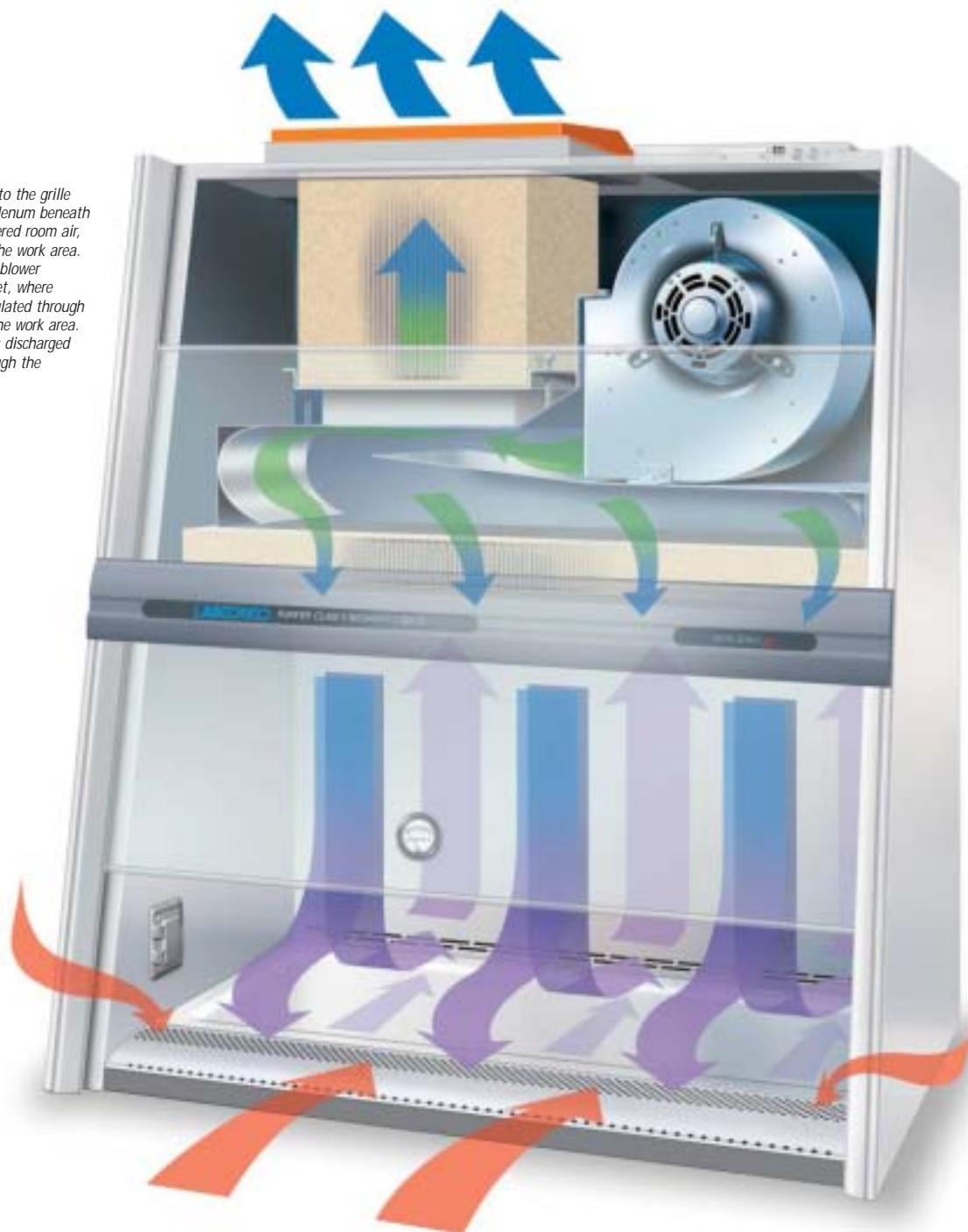

# △ Purifier® Delta® Series Class II, Type A2 Safety Cabinets

## FEATURES & BENEFITS

99.99% efficient HEPA filters.

Optional 254 nm UV lamp.

Leak-tight Type 304 stainless steel liner.

△ ADA-compliant sash position alarm.

Glare-free fluorescent lighting.

Fully-closing clear 0.25" tempered safety glass sash.

△ ADA-compliant single switch fluorescent light and blower start-up.

△ Eye-level Minihelic II pressure gauge.

Type 304 stainless steel, removable, stamped, one-piece dished work surface.

Optional ADA-compliant service fixtures.

Two ADA-compliant electrical duplex receptacles.



△ Safety color-coded towel catch.

△ Reserve-Air™ Secondary Airflow Slots.

△ Curved air foil.

Accessory Telescoping Base Stand. See pages 58 and 59 for ordering information.



Accessory Hydraulic Lift Base Stand. See pages 60 and 61 for ordering information.



Optional audible/visual low velocity alarm indicator.



△ Exclusive feature

# △ Purifier® Delta® Series Class II, Type A2 Safety Cabinets

## FEATURES & BENEFITS

△ **Eye-level Minihelic II pressure gauge** is mounted inside the cabinet instead of externally so that should a leak develop around the gauge, contaminants would be directed through a HEPA filter instead of being released into the laboratory.

△ **Safety color-coded towel catch**, located beneath the work surface, prevents wipes from being drawn into the blower where they could damage components and alter airflow.

**99.99% efficient HEPA filters** are industry standard sizes for economical replacement.



△ **Curved air foil** gently supports the user's forearms while preventing the potentially dangerous practice of placing materials in this area.

△ **Reserve-Air™ Secondary Airflow Slots** draw air into the cabinet should the operator inadvertently block the air foil's grille area. Safe airflow is always maintained.

△ **ADA-compliant single switch fluorescent light and blower start up.**

△ **ADA-compliant sash position alarm** is activated when the sash is raised above its 8" or 10" operating height. The alarm system may be easily muted or reset from the control panel switch.

**Two ADA-compliant electrical duplex receptacles**, located one on each side, with ground fault interruption and splash covers.

**Unitized, 16 gauge stainless steel frame** provides a more stable and accurate foundation than multi-piece designs so potential for leaks is minimized.

**Variable speed blower** with solid state control is sized for low power consumption.

**Intrinsically-safe negative pressure design.** All contaminated ducts are under negative pressure. The negative pressure plenums capture any contamination, and force the air through the exhaust HEPA filter, preventing its escape into the laboratory.

**Fully-closing, clear 0.25" tempered safety glass sash** with anti-racking mechanism is sloped at 10° for less glare and closer, more comfortable viewing than vertical sashes offer. For easy loading and cleaning, the sash may be raised to a maximum height of 18".

△ **Tactile indication when sash is raised to optimum operating level.** A sash position indicator decal provides a visual verification of the proper working height.

**Leak-tight Type 304 stainless steel liner and removable stamped, one-piece dished work surface.**

△ **Air-Wave™ Entry System**, consisting of the curved design of the side posts, air foil and sash handle, ensures smooth airflow into the interior minimizing turbulence and enhancing containment.

△ **Contain-Air™ Negative Pressure Channel** draws air in, preventing loss of containment at the top of the sash. Unreliable seals and gaskets, which could degrade or drag on the contaminated glass creating aerosols, are not used.

△ **Low profile front panel** is free of protrusions that could interfere with visibility or obstruct taller users.

**Glare-free fluorescent lighting**, located outside the work area, remains uncontaminated and is easily replaced.

**Full three year warranty on parts and service.**

**NSF International and ETL listed.** All 115 volt, 60 Hz, Purifier Delta Series Safety Cabinets carry the NSF International and ETL marks, signifying that the Purifier meets or exceeds all minimum requirements of the NSF Standard 49 for Biohazard Cabinetry, conforms to UL Standard 3101-1 in the U.S., and is certified to CAN/CSA C22.2 No. 1010.1-92 in Canada.

**CE mark.** All 230 volt, 50 Hz Purifiers conform to the following CE (European Community) requirements as tested by the Inchcape Testing Services (UK) LTD: Electrical Safety Standard: IEC 1010-1 and Electromagnetic Compatibility Directive: 89/336/EEC.

**Optional 254 nm UV lamp** for secondary decontamination while the cabinet is not in use. Interlocked switch permits the UV light to operate only when the fluorescent light and blower are off and the sash is completely closed.

**Optional ADA-compliant service fixtures** are mounted 9" above the work surface to maximize usable surface area. Service fixtures are available factory-installed or may be ordered separately.

**Optional audible/visual low velocity alarm indicator.** International models that include an on/off power lock with key are approved by European Standard BS EN 12469 *Biotechnology—Performance Criteria for Microbiological Safety Cabinets*. Contact Labconco at 800-821-5525 or 816-333-8811 for ordering information on other models with a low velocity alarm indicator.

**Accessory Adjustable Height Base Stands.** Purifier Delta Series Safety Cabinets are benchtop design for use on Labconco Telescoping, Hydraulic Lift and Seismic Base Stands.

△ Exclusive feature

# Purifier® Delta® Series Class II, Type A2 Safety Cabinets

## ORDERING INFORMATION

### Standard Features

- Nominal inflow velocity of 105 feet per minute (fpm)
- Nominal downflow velocity of 55 fpm
- Approximately 70% air recirculation
- Intrinsically-safe negative pressure design
- Two 99.99% efficient HEPA filters
- Unitized 16 gauge stainless steel substructure
- Crevice-free, type 304 stainless steel interior and removable, seamless, dished work surface
- Epoxy-coated exterior
- △ Safety color-coded and epoxy-coated steel towel catch, sash pocket and perforated exhaust filter cap
- △ 10° angled, sliding, fully-closing, 0.25" tempered safety glass sash with anti-racking mechanism, tactile position indicator and 18" maximum loading height
- △ Air-Wave™ Entry System
- △ Stainless steel air foil with Reserve-Air™ Secondary Airflow Slots
- △ Contain-Air™ Negative Pressure Channel
- △ Eye-level, ADA-compliant, inside-mounted Minihelic II pressure gauge
- △ ADA-compliant, single switch fluorescent light and blower start up
- △ ADA-compliant audible/visual alarm indicator with mute switch
  - Two ADA-compliant electrical duplex receptacles with ground fault interrupters and splash covers
  - 9.5' power cord\*
- △ Sure-Start™ voltage-compensating speed control with 40 amp capacity
  - Thermally-protected permanent split capacitor motor/blower(s)
  - Class 5 conditions per ISO 14644-1 and 2 (formerly Class 100)
  - NSF and ETL Listed (115 volt models)
  - CE conformity marking (230 volt models)
  - EN 12469 approved (Models 3620930 and 3620934)
  - Three year warranty on parts and labor

### Standard Option Package

- 254 nm UV lamp with interlocking safety switch allowing operation only when blower and fluorescent light are off and sash is fully closed
- Chrome-plated forged brass service fixture(s) with quarter turn handle, factory installed 9" above work surface

### Required Accessory

- Supporting base. See pages 58-62.

See page 66 for dimensional drawings.

△ Exclusive feature

\* Power cord on 6' cabinets for 100 and 115 volt operation is 8'.



Purifier Delta Series Class II, Type A2 Safety Cabinet 3620404 on Telescoping Base Stand 3730300.

# Purifier® Delta® Series Class II, Type A2 Safety Cabinets

## ORDERING INFORMATION

Catalog #	Nominal Width	Sash Opening	Exhaust Volume	Electrical Requirements	Power Cord & Plug	Light(s)	Service Fixture(s)	Shipping Weight
3620400	3 feet	10"	253-279 CFM	115 volts, 60 Hz, 12 amps	115 volts, 15 amps	Fluorescent	—	505 lbs. (229 kg)
3620404	3 feet	10"	253-279 CFM	115 volts, 60 Hz, 12 amps	115 volts, 15 amps	Fluorescent Ultraviolet	1	505 lbs. (229 kg)
3620500	3 feet	8"	203-223 CFM	115 volts, 60 Hz, 12 amps	115 volts, 15 amps	Fluorescent	—	505 lbs. (229 kg)
3620504	3 feet	8"	203-223 CFM	115 volts, 60 Hz, 12 amps	115 volts, 15 amps	Fluorescent Ultraviolet	1	505 lbs. (229 kg)
3620510*	3 feet	8"	203-223 CFM	100 volts, 50/60 Hz, 12 amps	115 volts, 15 amps	Fluorescent	—	505 lbs. (229 kg)
3620514*	3 feet	8"	203-223 CFM	100 volts, 50/60 Hz, 12 amps	115 volts, 15 amps	Fluorescent Ultraviolet	1	505 lbs. (229 kg)
3620520*	3 feet	8"	203-223 CFM	230 volts, 50 Hz, 7 amps	230 volts, 10 amps, no plug	Fluorescent	—	505 lbs. (229 kg)
3620524*	3 feet	8"	203-223 CFM	230 volts, 50 Hz, 7 amps	230 volts, 10 amps, no plug	Fluorescent Ultraviolet	1	505 lbs. (229 kg)
3620800	4 feet	10"	339-370 CFM	115 volts, 60 Hz, 12 amps	115 volts, 15 amps	Fluorescent	—	606 lbs. (275 kg)
3620804	4 feet	10"	339-370 CFM	115 volts, 60 Hz, 12 amps	115 volts, 15 amps	Fluorescent Ultraviolet	1	606 lbs. (275 kg)
3620900	4 feet	8"	269-296 CFM	115 volts, 60 Hz, 12 amps	115 volts, 15 amps	Fluorescent	—	606 lbs. (275 kg)
3620904	4 feet	8"	269-296 CFM	115 volts, 60 Hz, 12 amps	115 volts, 15 amps	Fluorescent Ultraviolet	1	606 lbs. (275 kg)
3620910*	4 feet	8"	269-296 CFM	100 volts, 50/60 Hz, 12 amps	115 volts, 15 amps	Fluorescent	—	606 lbs. (275 kg)
3620914*	4 feet	8"	269-296 CFM	100 volts, 50/60 Hz, 12 amps	115 volts, 15 amps	Fluorescent Ultraviolet	1	606 lbs. (275 kg)
3620920*	4 feet	8"	269-296 CFM	230 volts, 50 Hz, 7 amps	230 volts, 10 amps, no plug	Fluorescent	—	606 lbs. (275 kg)
3620924*	4 feet	8"	269-296 CFM	230 volts, 50 Hz, 7 amps	230 volts, 10 amps, no plug	Fluorescent Ultraviolet	1	606 lbs. (275 kg)
3620930*†	4 feet	8"	269-296 CFM	230 volts, 50 Hz, 7 amps	230 volts, 10 amps, no plug	Fluorescent	—	606 lbs. (275 kg)
3620934*†	4 feet	8"	269-296 CFM	230 volts, 50 Hz, 7 amps	230 volts, 10 amps, no plug	Fluorescent Ultraviolet	1	606 lbs. (275 kg)
3621200	6 feet	10"	503-554 CFM	115 volts, 60 Hz, 16 amps	115 volts, 20 amps	Fluorescent	—	843 lbs. (382 kg)
3621204	6 feet	10"	503-554 CFM	115 volts, 60 Hz, 16 amps	115 volts, 20 amps	Fluorescent Ultraviolet	2	843 lbs. (382 kg)
3621300	6 feet	8"	403-443 CFM	115 volts, 60 Hz, 16 amps	115 volts, 20 amps	Fluorescent	—	843 lbs. (382 kg)
3621304	6 feet	8"	403-443 CFM	115 volts, 60 Hz, 16 amps	115 volts, 20 amps	Fluorescent Ultraviolet	2	843 lbs. (382 kg)
3621310*	6 feet	8"	403-443 CFM	100 volts, 50/60 Hz, 16 amps	115 volts, 20 amps	Fluorescent	—	843 lbs. (382 kg)
3621314*	6 feet	8"	403-443 CFM	100 volts, 50/60 Hz, 16 amps	115 volts, 20 amps	Fluorescent Ultraviolet	2	843 lbs. (382 kg)
3621320*	6 feet	8"	403-443 CFM	230 volts, 50 Hz, 8 amps	230 volts, 10 amps, no plug	Fluorescent	—	843 lbs. (382 kg)
3621324*	6 feet	8"	403-443 CFM	230 volts, 50 Hz, 8 amps	230 volts, 10 amps, no plug	Fluorescent Ultraviolet	2	843 lbs. (382 kg)

\* International electrical configuration

† Includes audible/visual low velocity indicator and on/off power lock with key.

### Installation Requirements

**Location.** Locate the cabinet away from traffic patterns, doors, fans, ventilation registers and other air handling devices.

**Electrical.** The cabinet requires a dedicated electrical receptacle and circuit breaker with current capacity equal to or greater than the electrical requirements provided in the ordering information.

**Services.** All service lines must be 0.25" OD metal tubing and equipped with an easily accessible shut-off valve located outside the cabinet. Line pressure should not exceed 40 psi.

**Space.** Clearance of at least 6 inches on the sides and rear of the cabinet is recommended.

**Overhead Clearance.** Class II, Type A2 cabinets should have at least 6 inches clearance between the top of the exhaust cover and the ceiling.

**Certification.** Prior to initial use, the cabinet must be certified by a qualified certifier. Under normal operating conditions, the cabinet should be recertified at least annually, and when moved or serviced.

# Purifier® Delta® Series Class II, Type A2 Safety Cabinets

## ACCESSORIES



### Airflow Monitor

Continuously monitors the volume of air exhausted from the cabinet. Should the exhaust (inflow) volume drop below the setpoint, the red warning light is activated.

**Requires factory installation.** Contact Labconco at 800-821-5525, 816-333-8811 or labconco@labconco.com for ordering information.



### Safety Orange Air Foil

Bold orange color cautions the operator to avoid storing or placing materials in this area where airflow is critical. The air foil is epoxy-coated stainless steel and may be factory installed or retrofitted on site. Contact Labconco at 800-821-5525, 816-333-8811 or labconco@labconco.com for ordering information.



NSE

### Telescoping Base Stands

Epoxy-coated steel, adjust in 1" increments to provide a working height from 30 to 36". Available with fixed feet or casters. See pages 58 and 59 for ordering information.



NSE

### Hydraulic Lift Base Stands

Epoxy-coated steel, with infinite height adjustment using push button or hand crank. See pages 60 and 61 for ordering information.



### Seismic Base Stands

Epoxy-coated 2" tubular steel, secure cabinets in earthquake-prone regions. See page 62 for more information.



### 3747500 Service Fixture Kit

Includes serrated hose tip valve with quarter turn control handle, hardware and instructions for plumbing to services. Mounts on left or right side interior. Cabinets are factory-prepared to accommodate up to four fixtures. Shipping weight 4 lbs. (2 kg)



### Ultraviolet Lamp Kits

Include 254 nm UV lamp and installation instructions. Kit 3745000 also includes a ballast.

Catalog #	For use with	Shipping Weight
3745000	3-Ft and 4-Ft Purifier Delta Series	5 lbs. (2.3 kg)
3745001	6-Ft Purifier Delta Series	3 lbs. (1.4 kg)

### IV Bar Kits

Bar supports intravenous solution bottles and bags. Kits include IV bar, mounting hardware, four hangers and instructions for installation.

Catalog #	For use with	Shipping Weight
3745500	3-Ft Purifier Delta Series	3.0 lbs. (1.4 kg)
3745501	4-Ft Purifier Delta Series	4.0 lbs. (1.8 kg)
3745502	6-Ft Purifier Delta Series	6.0 lbs. (2.7 kg)



### Canopy Connection Kits for Thimble Ducting Purifier Delta Series Cabinet to Outside

Include an epoxy-coated steel exhaust transition adapter. Remote Blower 3668000 or 3668001 is recommended (not included). See page 63 for more information.

Catalog #	For use with	Duct Diameter	Shipping Weight
3794400	3-Ft Purifier Delta Series	10"	13 lbs. (5.9 kg)
3794500	4-Ft Purifier Delta Series	10"	13 lbs. (5.9 kg)
3794600	6-Ft Purifier Delta Series	10"	13 lbs. (5.9 kg)



### 3776800 Air-Tight Damper

Mounts atop the Canopy Connection Kit to adjust exhaust airflow and closes for decontamination procedures. Shipping weight 13 lbs. (5.9 kg). See page 59 for more information.



### Remote Blowers

Belt drive with adjustable sheave and integral damper. Inlet accepts 10" nominal diameter duct. Outlet accepts 8" nominal diameter duct. See page 63 for more information.

Catalog #	For use with	Shipping Weight
3668000	3-Ft and 4-Ft Purifier Delta Series	93 lbs. (42 kg)
3668001	6-Ft Purifier Delta Series	99 lbs. (45 kg)



### 3744000 Ergonomic Chair with Armrests

Chair has 6-way articulating seat and back control for personalized adjustment. Pneumatic mechanism adjusts seat height from 18.25" to 25.75". Five-leg black reinforced composite base rests on 2" ball bearing casters. Aluminum support ring. Removable arm rests. Black vinyl upholstery. Shipping weight 35 lbs. (15.9 kg)



### 3746000 Adjustable Footrest

Elevates feet and permits angle repositioning while in use. 18.5" w x 11.5" d x 8" high. Shipping weight 6 lbs. (2.7 kg)



### 8022000 Delta Cart

Provides convenient storage of supplies. Shipping weight 50 lbs. (23 kg) See page 57 for more information.

# Purifier® Delta® Series Class II, Type A2 & B2 Safety Cabinets

## DUCTWORK

### Thermoplastic Duct

PVC exhaust duct in 10' length. A Female Duct Coupling and solvent cement are required to join two sections.

Catalog #	4718900	7027200	5602000
Nominal Diameter	8"	10"	12"
Actual OD	8.625"	10.750"	12.750"
Actual ID	8.250"	10.375"	12.375"
Shipping Weight	35 lbs. (16 kg)	50 lbs. (23 kg)	65 lbs. (29 kg)

### Female Duct Couplings

PVC coupling joins two sections of Thermoplastic Duct.

Catalog #	4719200	7027500	5602300
Nominal Diameter	8"	10"	12"
Shipping Weight	5 lbs. (2 kg)	5 lbs. (2 kg)	6 lbs. (3 kg)
Equivalent Resistance*	0	0	0

### 90° Elbows

PVC Elbow has belled end connections to receive Thermoplastic Duct or Male Duct Coupling directly.

Catalog #	4719000	7027300	5602100
Nominal Diameter	8"	10"	12"
Shipping Weight	10 lbs. (4 kg)	12 lbs. (5 kg)	14 lbs. (6 kg)
Equivalent Resistance*	15 ft.	20 ft.	25 ft.

### Male Duct Couplings

PVC duct in 6" length. Facilitates connection between Remote Blowers #3668000, 3668001, or 3663500 and 90° Elbow.

Catalog #	7027800	7067300
Nominal Diameter	10"	12"
Actual OD	10.750"	12.750"
Actual ID	10.375"	12.375"
Shipping Weight	5 lbs. (2 kg)	6 lbs. (3 kg)

### Flexible Duct Connections

Reduces vibration between the blower and PVC ductwork. Supplied with two clamps.

Catalog #	7034200	5621400
Nominal Diameter	11" for use with 10" fittings	13" for use with 12" fittings
Shipping Weight	5 lbs. (2 kg)	5 lbs. (2 kg)

### Thermoplastic Duct Reducer

PVC coupling type reducer joins PVC duct of different diameters.

Catalog #	5606100
Nominal Size	10" x 12"
Shipping Weight	6 lbs. (3 kg)
Equivalent Resistance*	0

### Zero Pressure Weathercaps

PVC Weathercap fits atop standard PVC duct, permits vertical discharge of effluent air above roofline for dispersion away from the building.

Catalog #	4722300	7095100	5622100
Nominal Diameter	8"	10"	12"
Shipping Weight	25 lbs. (11 kg)	30 lbs. (14 kg)	35 lbs. (16 kg)
Height	40"	48"	56"
Equivalent Resistance*	5 ft.	5 ft.	5 ft.

\*Equivalent resistance is measured in feet of straight duct.

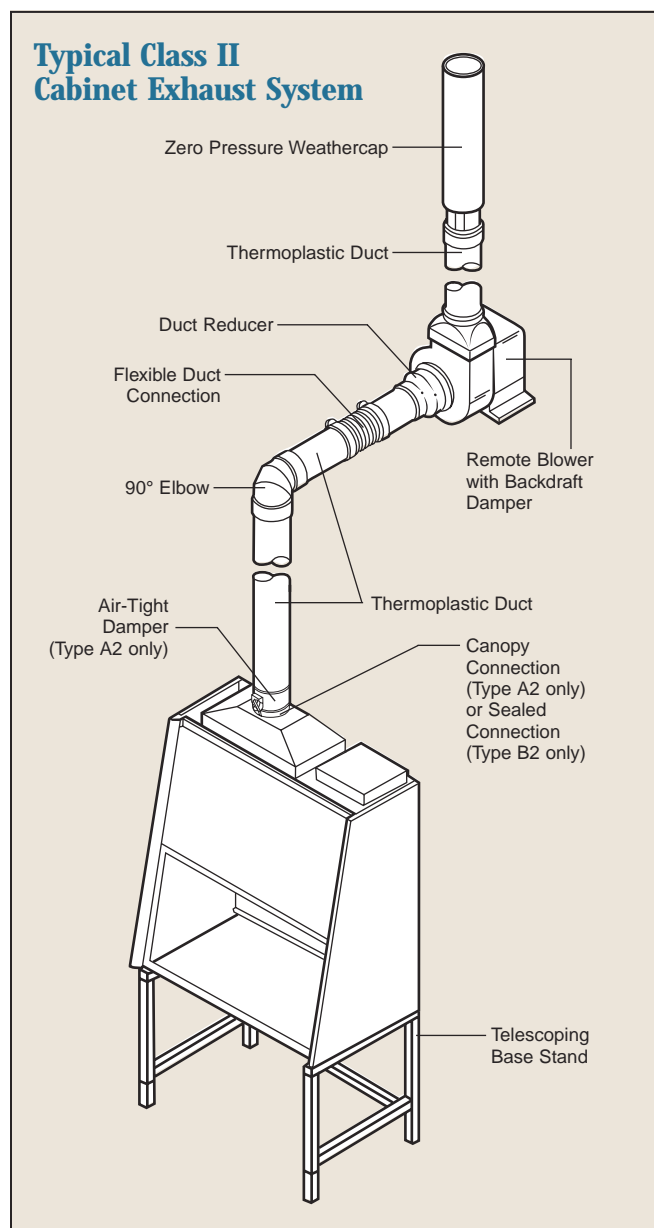

Contact Labconco at 800-821-5525 or 816-333-8811 for technical assistance in selecting the right ductwork for your installation.



# Purifier® Delta® Series Total Exhaust Safety Cabinets

## INTRODUCTION

Like the Class II, Type A2 Cabinet, the Purifier Delta Series Total Exhaust (Class II, Type B2) Safety Cabinet protects you, your work and your laboratory environment. **It is suitable for work with agents that require Biosafety Level 1, 2 or 3 containment.** One hundred percent of the air that moves through it is exhausted to the outside. Because none of the air in the cabinet is recirculated, the Purifier Delta Series Total Exhaust Cabinet may be used for work with

agents treated with volatile toxic chemicals and radionuclides when required as an adjunct to microbiological research.

This cabinet is equipped with an interlocking alarm system that constantly monitors the volume of air exhausted. If the exhaust air volume drops below an acceptable level, an audible alarm sounds, the alarm light glows red, and the cabinet blowers stop. This added measure of safety protects you from inadvertent exposure to aerosols.

*During operation, room air is drawn through the top of the cabinet. This air is HEPA filtered, and then flows downward through the work area. Room air is also drawn into the grille located in the airfoil. All of the contaminated air is drawn under the work surface or through the rear grille, then up the rear plenum, and through the exhaust HEPA filter. A dedicated exhaust system and remote blower draw 100% of the filtered exhaust air out of the laboratory. The ductwork and remote blower are required for operation and sold separately.*

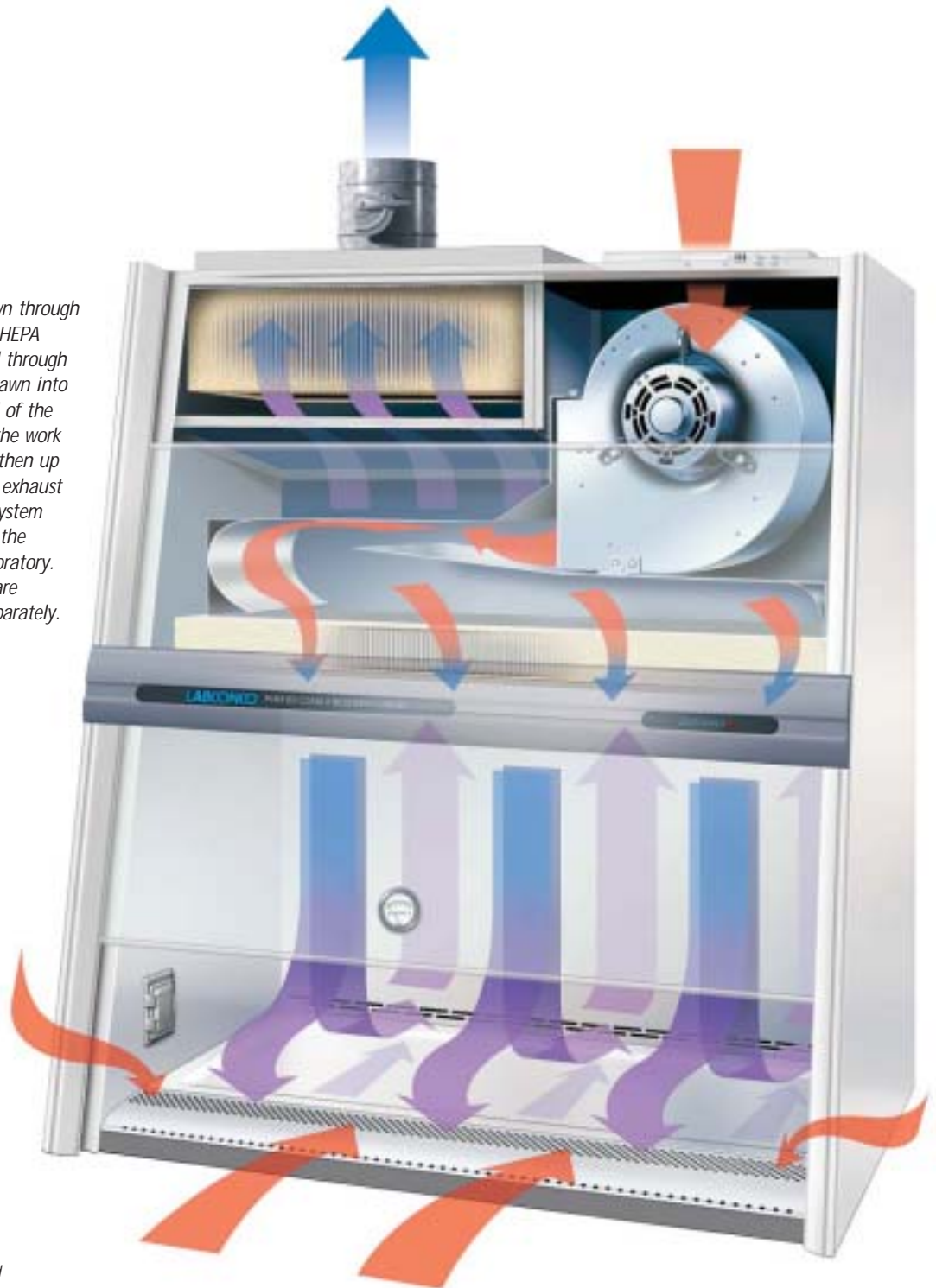
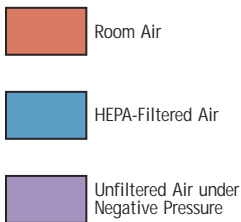

# Purifier® Delta® Series Total Exhaust Safety Cabinets

## FEATURES & BENEFITS

99.99% efficient HEPA filters.

Glare-free fluorescent lighting.

Optional 254 nm UV lamp.

Fully closing, clear 0.25" tempered safety sash.

Eye-level Minihelic II pressure gauge.

△ Curved air foil.

△ Reserve-Air™ Secondary Airflow Slots.



△ Safety color-coded towel catch.



Optional ADA-compliant service fixtures.

Leak-tight Type 304 stainless steel liner.

△ ADA-compliant exhaust/sash position alarm system.

△ ADA-compliant single switch fluorescent light and blower start-up.

Two ADA-compliant electrical duplex receptacles.

Type 304 stainless steel, removable, stamped, one-piece dished work surface.

Accessory Telescoping Base Stand. See pages 60 and 61 for ordering information.



△ Exclusive feature

# Purifier® Delta® Series Total Exhaust Safety Cabinets

## FEATURES & BENEFITS

△ **Eye-level Minihelic II pressure gauge** is mounted inside the cabinet instead of externally so that should a leak develop around the gauge, contaminants would be directed through a HEPA filter instead of being released into the laboratory.

△ **Safety color-coded sash pocket** encases the sash as it is raised, shielding the user and environment from exposure to potential contamination on the interior side of the sash.



△ **Safety color-coded towel catch** prevents wipes from being drawn into the exhaust filter where damage can occur and airflow can be altered.

**99.99% efficient HEPA filters** are industry standard sizes for economical replacement.



△ **Curved air foil** gently supports the user's forearms while preventing the potentially dangerous practice of placing materials in this area.

△ **Reserve-Air™ Secondary Airflow Slots** draw air into the cabinet should the operator inadvertently block the air foil's grille area. Safe airflow is always maintained.

△ **ADA-compliant single switch fluorescent light and blower start up.**

△ **ADA-compliant exhaust/sash position alarm system** is activated when insufficient exhaust air volume is detected and/or the sash is raised above its operating height. The cabinet blowers are automatically deactivated in the event of insufficient exhaust air volume. The alarm system may be easily muted or reset from the control panel switch.

**Two ADA-compliant electrical duplex receptacles** with ground fault interruption and splash covers.

**Unitized, 16 gauge stainless steel frame** provides a more stable and accurate foundation than multi-piece designs so potential for leaks is minimized.

**Variable speed blower** with solid state control is sized for low power consumption. **An additional remote blower is required for operation.** See page 60 for ordering information.

**Intrinsically-safe negative pressure design.** All contaminated ducts are under negative pressure. The negative pressure plenums capture any contamination, and force the air through the exhaust HEPA filter, preventing its escape into the laboratory.

**Fully-closing, clear 0.25" tempered safety glass sash** with anti-racking mechanism is sloped at 10° for less glare and closer, more comfortable viewing than vertical sashes offer. For easy loading and cleaning, the sash may be raised to a maximum height of 18".

△ **Tactile indication when sash is raised to optimum operating level.** A sash position indicator decal provides a visual verification of the proper working height.

**Leak-tight Type 304 stainless steel liner and removable stamped, one-piece dished work surface.**

△ **Air-Wave™ Entry System**, consisting of the curved design of the side posts, air foil and sash handle, ensures smooth airflow into the interior minimizing turbulence and enhancing containment.

△ **Contain-Air™ Negative Pressure Channel** draws air in, preventing loss of containment at the top of the sash. Unreliable seals and gaskets, which could degrade or drag on the contaminated glass causing aerosolization, are not used.

△ **Low profile front panel** is free of protrusions that could interfere with visibility or obstruct taller users.

**Glare-free fluorescent lighting**, located outside the work area, remains uncontaminated and is easily replaced.

**Full three year warranty on parts and service.**

**NSF International and ETL listed.** All 115 volt, 60 Hz, Purifier Delta Series Safety Cabinets carry the NSF International and ETL marks, signifying that the Purifier meets or exceeds all minimum requirements of the NSF Standard Number 49 for Biohazard Cabinetry, conforms to UL Standard 3101-1 in the U.S., and is certified to CAN/CSA C22.2 No. 1010.1-92 in Canada.

**CE mark.** All 230 volt, 50 Hz Purifiers conform to the following CE (European Community) requirements as tested by the Inchcape Testing Services (UK) LTD: Electrical Safety Standard: IEC 1010-1 and Electromagnetic Compatibility Directive: 89/336/EEC.

**Optional 254 nm UV lamp** for secondary decontamination while the cabinet is not in use. Interlocked switch permits the UV light to operate only when the fluorescent light and blower are off and the sash is completely closed.

**Optional ADA-compliant service fixtures** are mounted 9" above the work surface to maximize usable surface area. Service fixtures are available factory-installed or separately.

**Accessory Supporting Telescoping Base Stand.**

Purifier Delta Series Safety Cabinets are benchtop design for use on Labconco Telescoping Base Stands with working heights from 30-36" or existing casework. Fixed height Seismic Base Stands are also available.

△ Exclusive feature

# Purifier® Delta® Series Total Exhaust Safety Cabinets

## ORDERING INFORMATION

### Standard Features

- Nominal inflow velocity of 105 feet per minute (fpm)
- Nominal downflow velocity of 55 fpm
- 0% air recirculation
- Intrinsically-safe negative pressure design
- Two 99.99% efficient HEPA filters
- Unitized 16 gauge stainless steel substructure
- Crevice-free, type 304 stainless steel interior and removable, seamless, dished work surface
- Epoxy-coated exterior
- △ Safety color-coded epoxy-coated steel towel catch and sash pocket
- △ 10° angled, sliding, fully-closing, 0.25" tempered safety glass sash with anti-racking mechanism and tactile position indicator
- △ Air-Wave™ Entry System
- △ Stainless steel air foil with Reserve-Air™ Secondary Airflow Slots
- △ Contain-Air™ Negative Pressure Channel
- △ Eye-level ADA compliant Minihelic II pressure gauge
- △ ADA-compliant single switch for fluorescent light and blower start up
- △ ADA-compliant audible/visual, exhaust/sash position alarm indicator and mute switch
- Two ADA-compliant electrical duplex receptacles with ground fault interrupters and splash covers
- △ Sure-Start™ voltage-compensating speed control with 40 amp capacity
- Thermally-protected, permanent-split capacitor, 1/3 hp motor/blower
- Airflow adjustment damper
- Class 5 conditions per ISO 14644-1 and 2 (formerly Class 100)
- NSF and ETL listings on 115 volt models
- CE conformity marking on 230 volt models
- Three year warranty on parts and labor



Purifier Delta Series Total Exhaust Safety Cabinet 3621404 on Telescoping Base Stand 3730600.

### Standard Option Package

- 254 nm UV lamp with interlocking safety switch allowing operation when blower and fluorescent light are off and sash is fully closed
- Chrome-plated forged brass service fixture(s) with quarter turn handle, factory installed 9" above work surface

### Required Accessory

- Supporting base. See pages 58-62.

See page 23 for Installation Requirements. See page 67 for dimensional drawings.

Catalog #	Nominal Width	Sash Opening	Exhaust Volume	Electrical Requirements	Power Cord & Plug	Light(s)	Service Fixture(s)	Shipping Weight
3621000	4 feet	8"	743-771 CFM	115 volts, 60 Hz, 12 amps	115 volts, 15 amps	Fluorescent	—	736 lbs. (334 kg)
3621004	4 feet	8"	743-771 CFM	115 volts, 60 Hz, 12 amps	115 volts, 15 amps	Fluorescent Ultraviolet	1	736 lbs. (334 kg)
3621010*	4 feet	8"	743-771 CFM	100 volts, 50/60 Hz, 12 amps	115 volts, 15 amps	Fluorescent	—	736 lbs. (334 kg)
3621014*	4 feet	8"	743-771 CFM	100 volts, 50/60 Hz, 12 amps	115 volts, 15 amps	Fluorescent Ultraviolet	1	736 lbs. (334 kg)
3621020*	4 feet	8"	743-771 CFM	230 volts, 50/60 Hz, 7 amps	230 volts, 10 amps no plug	Fluorescent	—	736 lbs. (334 kg)
3621024*	4 feet	8"	743-771 CFM	230 volts, 50/60 Hz, 7 amps	230 volts, 10 amps no plug	Fluorescent Ultraviolet	1	736 lbs. (334 kg)
3621400	6 feet	8"	1111-1151 CFM	115 volts, 60 Hz, 12 amps	115 volts, 15 amps	Fluorescent	—	875 lbs. (397 kg)
3621404	6 feet	8"	1111-1151 CFM	115 volts, 60 Hz, 12 amps	115 volts, 15 amps	Fluorescent Ultraviolet	2	875 lbs. (397 kg)
3621410*	6 feet	8"	1111-1151 CFM	100 volts, 50/60 Hz, 12 amps	115 volts, 15 amps	Fluorescent	—	875 lbs. (397 kg)
3621414*	6 feet	8"	1111-1151 CFM	100 volts, 50/60 Hz, 12 amps	115 volts, 15 amps	Fluorescent Ultraviolet	2	875 lbs. (397 kg)

△ Exclusive feature

\*International electrical configuration

# Purifier® Delta® Series Total Exhaust Safety Cabinets

## ACCESSORIES



### Safety Orange Air Foil

Bold orange color cautions the operator to avoid storing or placing materials in this area where airflow is critical. The air foil is epoxy-coated stainless steel and may be factory installed or retrofitted on site. Contact Labconco at

800-821-5525, 816-333-8811 or labconco@labconco.com for ordering information.

### Bag-In/Bag-Out Exhaust Filter

Bag-In/Bag-Out feature allows a contaminated exhaust HEPA filter to be removed from the cabinet without directly contacting it.

Contact Labconco at 800-821-5525, 816-333-8811 or labconco@Labconco.com for ordering information.



### Telescoping Base Stands

Epoxy-coated steel, adjust in 1" increments to provide a working height from 30 to 36". Available with fixed feet or casters. See pages 58 and 59 for more information.

NSE



### Seismic Base Stands

Epoxy-coated 2" tubular steel, secure cabinets in earthquake-prone regions. Fixed height. See page 58 for more information.



### 3747500 Service Fixture Kit

Includes serrated hose tip valve with quarter-turn control handle, hardware and instructions for plumbing to services. Mounts on left or right side interior. Cabinets are factory-prepared to accommodate up to four fixtures. Shipping weight 4 lbs. (2 kg)

### Ultraviolet Lamp Kits

Include 254 nm UV lamp and installation instructions. Kit 3745000 also includes a ballast.

Catalog #	For use with	Shipping Weight
3745000	4-Ft Purifier Delta Series	5 lbs. (2.3 kg)
3745001	6-Ft Purifier Delta Series	3 lbs. (1.4 kg)



### IV Bar Kits

Bar supports intravenous solution bottles and bags. Kits include IV bar, mounting hardware, four hangers and instructions for installation.

Catalog #	For use with	Shipping Weight
3745501	4-Ft Purifier Delta Series	4.0 lbs. (1.8 kg)
3745502	6-Ft Purifier Delta Series	6.0 lbs. (2.7 kg)



### 3663500 Remote Blower

Belt drive with adjustable sheave and integral backdraft damper. Inlet and outlet accept 12" nominal diameter duct. See page 64 for more information. Shipping weight 100 lbs. (45 kg)



### 3744000 Ergonomic Chair with Armrests

Chair has 6-way articulating seat and back control for personalized adjustment. Pneumatic mechanism adjusts seat height from 18.25" to 25.75". Five-leg black reinforced composite base rests on 2" ball bearing casters. Aluminum support ring. Removable arm rests. Black vinyl upholstery. Shipping weight 35 lbs. (15.9 kg)



### 3746000 Adjustable Footrest

Elevates feet and permits angle repositioning while in use. 18.5" w x 11.5" d x 8" high. Shipping weight 6 lbs. (2.7 kg)



### 8022000 Delta Cart

Provides convenient storage of supplies. Shipping weight 50 lbs. (23 kg) See page 57 for more information.



# Purifier® Horizontal Clean Benches

## INTRODUCTION

The Purifier Horizontal Clean Bench protects your work. It is the Class 100 work station of choice when you work with materials that do not generate harmful aerosols or vapors, yet require a particulate-free environment. Suitable applications for the bench include plant tissue culture research, media preparation, electronic part inspection, syringe filling, medical device assembly and parenteral drug formulation.

Because air from the work area is dispersed directly into the laboratory, Purifier Horizontal Clean Benches should never be used in conjunction with biohazardous material, toxins or radionuclides. You and your safety officer must carefully assess the risk associated with any operation performed in a clean bench.

During operation, room air is drawn through a pre-filter in the top of the bench to trap large particles. Then, the air flows through a 99.99% efficient HEPA filter and is projected horizontally across the entire work area. This HEPA-filtered air minimizes cross contamination in the work area and provides a particulate-free work environment.

Unique to the Purifier Horizontal Clean Bench is its double HEPA filter seal. The primary gasket seals the intake side of the filter to prevent unfiltered air from leaking into the work area. The secondary gasket at the front of the HEPA filter seals the downstream side of the filter frame. The area between these two gaskets is maintained under negative pressure. Should a leak occur at the primary HEPA filter gasket, the contaminated air is immediately recaptured and refiltered.

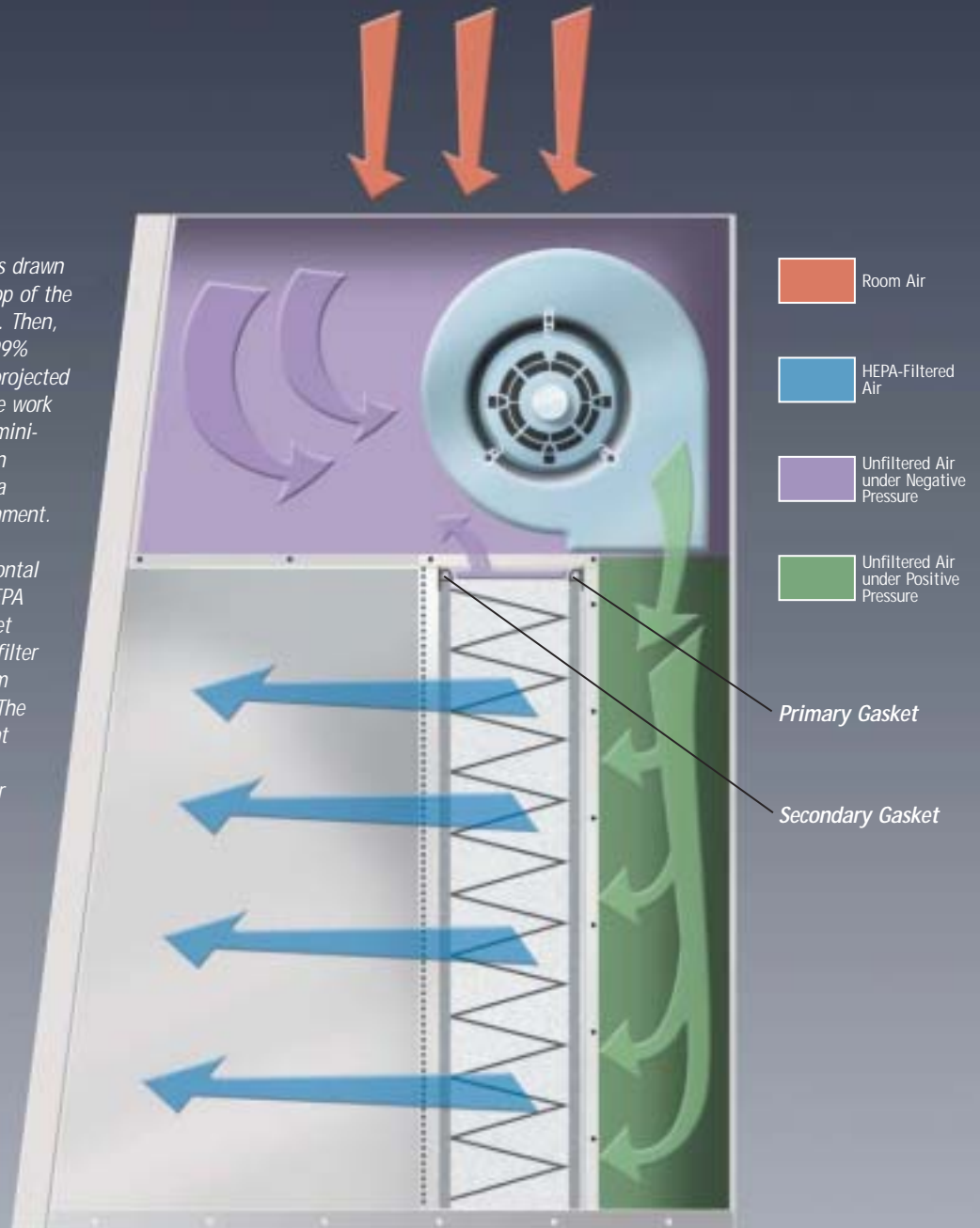

# Purifier® Horizontal Clean Benches

## FEATURES & BENEFITS

**Replaceable prefilters** trap large particles, extend HEPA filter life.

**99.99% efficient HEPA filter** is industry standard size for economical replacement.

**Low vibration, variable speed motor/blower** 1/3 hp on 3-foot models, 1/2 hp on 4-foot models, and two 1/4 hp motors on 6-foot models.

**Minihelic II pressure gauge** displays differential pressure across the HEPA filter.

**Particle-free ISO Class 5 air.** Particle counts in the work area conform to ISO 14644-1 and 2, providing ISO Class 5 conditions (formerly Class 100). This ensures fewer than 3520 particles 0.5 µm or larger per cubic meter of air.

**Full one year warranty on parts and service.**

**Optional Vibration Isolation Table.** See page 56 for ordering information.

**Glare-free fluorescent lighting.**

**CE Mark.** All 230 volt models conform to the following CE (European Community requirements for electrical safety and electromagnetic compatibility).

**Optional Vinyl Curtain** acts as a barrier when bench is not in use. See page 56 for ordering information.

**Accessory Telescoping Base Stand.** See pages 58 and 59 for ordering information.

**ETL listed.** All 115 volt, 60 Hz models carry the ETL mark signifying that they conform to UL Standard 3101-1 in the U.S. and are certified to CAN/CSA C22.2 No. 1010.1 in Canada.



**Accessory Telescoping Base Stand.** See pages 60 and 61 for ordering information.



 Exclusive feature

**Front-mounted light and blower switches.**

 **Angled profile design.** Front panel is free of protrusions that could interfere with visibility or obstruct taller users.



**Polarized and grounded electrical outlet(s).**

 **Double-gasket, negative pressure leak protection.**

**Optional service fixtures** available factory-installed or as kits for user installation. See page 56 for kit information.

**Dark gray, melamine-laminated hard board work surface.**

**Optional Type 304 brushed stainless steel work surface and sides.** Contact Labconco for ordering information.



**Optional factory-installed 254 nm UV light** for secondary decontamination while the bench is not in use. UV light switch is safety interlocked with fluorescent light and blower switches to help prevent inadvertent UV exposure while the bench is in operation.

# Purifier® Horizontal Clean Benches

## ORDERING INFORMATION

### Standard Features

- 99.99% efficient HEPA filter
- Prefilter
- Class 5 conditions per ISO 14644-1 and 2 (formerly Class 100)
- Minihelic II pressure gauge
- Double-gasket, negative pressure HEPA filter leak protection
- Front-mounted light and blower switches
- Variable speed motor/blower(s) with vibration isolation pads
- Fluorescent lighting
- Polarized and grounded electrical outlet(s)
- Glacier white epoxy-coated steel frame and exterior panels
- Dark gray melamine-laminated hard board work surface
- Angled front profile
- ETL listing (115 volt models)
- CE conformity marking (230 volt models)
- One year warranty on parts and service

### Standard Option Package

- Factory-installed, 254 nm UV lamp with interlocking safety switch allowing operation only when blower and fluorescent light are off
- Factory-installed, chrome-plated, forged brass service fixture(s) with quarter turn handle

### Required Accessory

- Supporting base. See page 58 and 59.



Purifier Horizontal Clean Bench 3610004 on Telescoping Base Stand 3746704.

See page 69 for dimensional drawings.

Exclusive feature

Catalog #	Nominal Width	Electrical Requirements	Power Cord & Plug	Light(s)	Electrical Outlets	Service Fixture(s)	Shipping Weight
3600000	3 feet	115 volts, 60 Hz, 12 amps	115 volts, 15 amps	Fluorescent	(1) 115 volt	—	305 lbs. (138 kg)
3600004	3 feet	115 volts, 60 Hz, 12 amps	115 volts, 15 amps	Fluorescent Ultraviolet	(1) 115 volt	1	305 lbs. (138 kg)
3600020*	3 feet	230 volts, 50 Hz, 7 amps	230 volts, 15 amps no plug	Fluorescent	(1) 230 volt (IEC 320)	—	305 lbs. (138 kg)
3600024*	3 feet	230 volts, 50 Hz, 7 amps	230 volts, 15 amps no plug	Fluorescent Ultraviolet	(1) 230 volt (IEC 320)	1	305 lbs. (138 kg)
3612500	4 feet	115 volts, 60 Hz, 12 amps	115 volts, 15 amps	Fluorescent	(1) 115 volt	—	370 lbs. (168 kg)
3612504	4 feet	115 volts, 60 Hz, 12 amps	115 volts, 15 amps	Fluorescent Ultraviolet	(1) 115 volt	1	370 lbs. (168 kg)
3612520*	4 feet	230 volts, 50 Hz, 7 amps	230 volts, 15 amps no plug	Fluorescent	(1) 230 volt (IEC 320)	—	370 lbs. (168 kg)
3612524*	4 feet	230 volts, 50 Hz, 7 amps	230 volts, 15 amps no plug	Fluorescent Ultraviolet	(1) 230 volt (IEC 320)	1	370 lbs. (168 kg)
3610000	6 feet	115 volts, 60 Hz, 16 amps	115 volts, 20 amps	Fluorescent	(2) 115 volt	—	515 lbs. (234 kg)
3610004	6 feet	115 volts, 60 Hz, 16 amps	115 volts, 20 amps	Fluorescent Ultraviolet	(2) 115 volt	2	515 lbs. (234 kg)
3610020*	6 feet	230 volts, 50 Hz, 8 amps	230 volts, 15 amps no plug	Fluorescent	(2) 230 volt (IEC 320)	—	515 lbs. (234 kg)
3610024*	6 feet	230 volts, 50 Hz, 8 amps	230 volts, 15 amps no plug	Fluorescent Ultraviolet	(2) 230 volt (IEC 320)	2	515 lbs. (234 kg)

\*International electrical configuration

# Purifier® Horizontal Clean Benches

## ACCESSORIES



### Telescoping Base Stands

Epoxy-coated steel frame, adjusts in 1" increments to provide a working height from 28.75 to 34.75". Available with fixed feet or casters. See pages 58 and 59 for more information.



### Hydraulic Lift Base Stands

Epoxy-coated steel, with infinite height adjustment using push button or hand crank. See pages 60 and 61 for ordering information.



### 3618000 Vibration Isolation Table

Provides an isolated work surface for conducting procedures with vibration-sensitive equipment such as microscopes and balances. The table never makes contact with the clean bench so vibration from the motor/blower is not transmitted to the

table. Epoxy-coated steel frame, adjusts in 1" increments to provide a working height from 29.5 to 36". ADA-compliant. Four leveling feet. Work surface is laminated hard board. 30.4" w x 18" d. Overall dimensions: 32.5" x 25" d x 29.5" to 36" high. Shipping weight 110 lbs. (49.9 kg)



### 3773700 Service Fixture Kit

Includes serrated hose tip valve with quarter turn control handle, hardware and instructions for plumbing to services. Up to two fixtures may be mounted on the right hand side of the Purifier Horizontal Clean Bench. Shipping weight 4 lbs. (2 kg)



### Vinyl Curtain Kits

Provide a barrier to airborne particulates while bench is not in use. Vinyl curtain attaches to top and bottom of bench opening with nylon-loop fastener, included.



### 3697500 IV Bar Kit

Supports intravenous solution bottles and bags. Kit includes IV bar, mounting hardware, four hangers and instructions for installation. Three-foot and four-foot Purifier Clean Benches accommodate one IV bar. Six-foot benches accommodate two. Shipping weight 5 lbs. (2.3 kg)



### 3744000 Ergonomic Chair with Armrests

Lab chair has 6-way articulating seat and back control for personalized adjustment. Pneumatic mechanism adjusts seat height from 18.25" to 25.75". Five-leg black reinforced composite base rests on 2" ball bearing casters. Aluminum support ring. Removable arm rests. Black vinyl upholstery. Shipping weight 35 lbs. (15.9 kg)



### 3746000 Adjustable Footrest

Elevates feet and permits angle repositioning while in use. 18.5" w x 11.5" d x 8" high. Shipping weight 6 lbs. (2.7 kg)

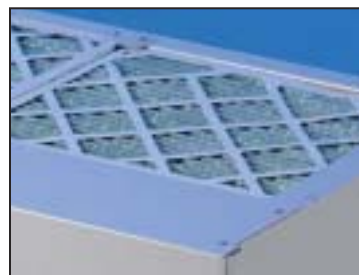

### Replacement Prefilters

Labconco recommends replacing prefilters every three months. One each. Shipping weight 1 lb. (0.4 kg)

Catalog #	For use with:	Shipping Weight
3773800	3-Ft Purifier Clean Benches	3 lbs. (1.4 kg)
3773801	4-Ft Purifier Clean Benches	4 lbs. (1.8 kg)
3773802	6-Ft Purifier Clean Benches	5 lbs. (2.3 kg)

Catalog #	For use with:	# Required
3768900	3-Ft Purifier Clean Benches	2
3768901	4-Ft Purifier Clean Benches	2
3768901	6-Ft Purifier Clean Benches	3

# Delta Cart

The Delta Cart was specifically designed to provide convenient storage of supplies commonly used in biological safety cabinets. Compartments hold and dispense pipettes, gloves, lab tissues and other small supplies. Its compact size allows it to fit easily under Purifier Delta Series Class II Safety Cabinets mounted on Telescoping Base Stands adjusted to any height. Casters and handles allow the cart to be easily moved to within reach while the user works at the biological safety cabinet.

## Standard Features

- Three right side compartments accommodate pipettes and other supplies.
- Top left side compartment with front panel cutouts accommodates boxes of wipes and gloves. The hinged panel may be pivoted down for loading.
- Drawer holds a variety of miscellaneous small instruments and supplies.
- Open storage area in bottom holds larger equipment and supplies.
- Work surface and bottom are constructed of corrosion-resistant white high density polyethylene that is easy to clean. Remaining components are constructed of corrosion-resistant white ABS.
- Compact dimensions allow easy fit under Purifier Delta Series Class II Safety Cabinets mounted on Telescoping Base Stands.
- Work surface is 25.0" w x 19.0" d (63.5 x 48.3 cm). Cabinet is 21.5" w x 17.4" d (54.6 x 44.2 cm). Overall height is 27.0" (68.6 cm).
- Work surface has handle cutouts in front and right hand side for easy access.
- 2" diameter casters provide mobility.



*Delta Cart 8022000.*

***Inset:** Delta Cart 8022000 stored beneath a Purifier Delta Series Class II, Type A2 Safety Cabinet 3620804 on Telescoping Base Stand 3730400.*



Catalog #	Description	Shipping Weight
8022000	Delta Cart	50 lbs. (23 kg)

# Tel escoping Base Stands

These stands have telescoping legs so that they may be adjusted to seven height positions.\* The stands are available with fixed feet or casters for mobility.

## Standard Features

- NSF-Listed
- Support any Purifier Delta Series Safety Cabinet, Purifier Clean Bench or Enclosure.
- Support loads up to 1000 pounds.
- ADA-compliant.
- Durable 1.75" tubular, epoxy-coated steel frame. Models 3' wide and larger have rear crossbar supports.
- Telescoping legs are adjustable to seven height positions in 1" increments from 27.5" to 33.5".\*
- Available with four fixed leveling feet or 5" diameter, toe-locking, non-marking polyurethane casters with bearings for quiet operation.

\*Height selection and adjustment are required **before** the enclosure is installed atop the stand.



**NSF.**

Telescoping Base Stand with Fixed Feet 3747010.



Inset: Telescoping Base Stand with Casters 3747010.

Model Numbers	Width	A	B
3747000, 3747010	2'	24.0"	25.5"
3747001, 3747011	3'	36.0"	25.5"
3746701, 3746711	3'	36.0"	29.0"
3730300, 3730310	3'	38.5"	29.0"
3747002, 3747012	4'	48.0"	25.5"
3746702, 3746712	4'	48.0"	29.0"
3730400, 3730410	4'	50.5"	29.0"
3746704, 3746714	6'	72.0"	29.0"
3730600, 3730610	6'	74.5"	29.0"

### WITH FIXED FEET

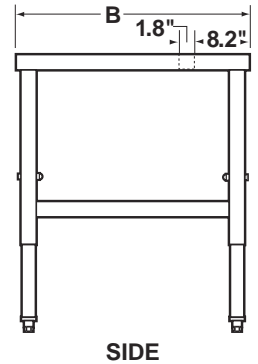
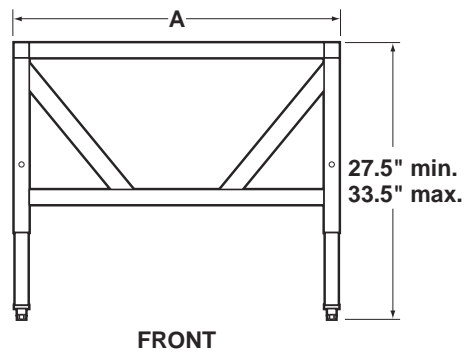

### WITH CASTERS

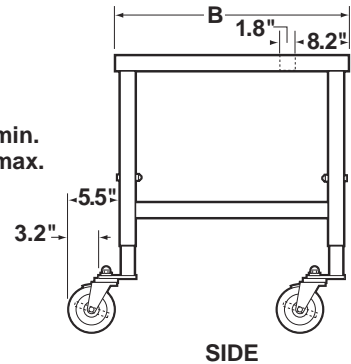
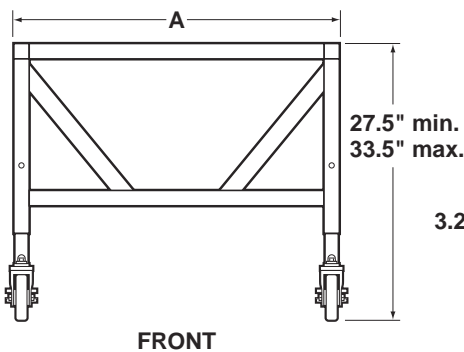

# Tel escoping Base Stands

## Telescoping Base Stands with Fixed Feet

Width	Catalog #	Overall Width x Depth	Shipping Weight	For Use With:
2-Ft	3747000	24.0" w x 25.5" d	75 lbs. (34 kg)	Purifier Class I enclosure, Purifier HEPA Filtered Enclosure, Purifier PCR Enclosure, Purifier Vertical Clean Bench
3-Ft	3747001	36.0" w x 25.5" d	95 lbs. (43 kg)	Protector VS Stations, Purifier Class I Enclosure, Purifier HEPA Filtered Enclosure, Purifier PCR Enclosure, Purifier Vertical Clean Bench
3-Ft	3746701	36.0" w x 29.0" d	100 lbs. (45 kg)	Purifier Horizontal Clean Bench, Purifier Forensic Enclosure, Purifier Trace Metals Work Station, Purifier Class 100 Chemical Station
3-Ft	3730300*	38.5" w x 29.0" d	110 lbs. (50 kg)	Purifier Delta Series Safety Cabinet
4-Ft	3746702	48.0" w x 29.0" d	110 lbs. (50 kg)	Purifier Horizontal Clean Bench
4-Ft	3730400*	50.5" w x 29.0" d	117 lbs. (58 kg)	Purifier Delta Series Safety Cabinet
6-Ft	3746704	72.0" w x 29.0" d	120 lbs. (54 kg)	Purifier Horizontal Clean Bench
6-Ft	3730600*	74.5" w x 29.0" d	130 lbs. (59 kg)	Purifier Delta Series Safety Cabinet

## Telescoping Base Stands with 5" diameter Toe-Locking Casters\*\*

Width	Catalog #	Overall Width x Depth	Shipping Weight	For Use With:
2-Ft	3747010	24.0" w x 25.5" d	80 lbs. (36 kg)	Purifier Class I Enclosure, Purifier HEPA Filtered Enclosure, Purifier PCR Enclosure, Purifier Vertical Clean Bench
3-Ft	3747011	36.0" w x 25.5" d	100 lbs. (45 kg)	Purifier Class I Enclosure, Purifier HEPA Filtered Enclosure, Purifier PCR Enclosure, Purifier Vertical Clean Bench
3-Ft	3746711	36.0" w x 29.0" d	105 lbs. (48 kg)	Purifier Horizontal Clean Bench, Purifier Forensic Enclosure, Purifier Trace Metals Work Station, Purifier Class 100 Chemical Station
3-Ft	3730310*	38.5" w x 29.0" d	115 lbs. (52 kg)	Purifier Delta Series Safety Cabinet
4-Ft	3746712	48.0" w x 29.0" d	115 lbs. (52 kg)	Purifier Horizontal Clean Bench
4-Ft	3730410*	50.5" w x 29.0" d	123 lbs. (56 kg)	Purifier Delta Series Safety Cabinet
6-Ft	3746714	72.0" w x 29.0" d	125 lbs. (57 kg)	Purifier Horizontal Clean Bench
6-Ft	3730610*	74.5" w x 29.0" d	135 lbs. (61 kg)	Purifier Delta Series Safety Cabinet

\*NSF-Listed

\*\*Enclosures supported by mobile Base Stands will require special modifications to incorporate flexible ducting, wiring and plumbing when applied.

### 3730500 Caster Kit

For converting Telescoping Base Stands with Fixed Feet manufactured after 10/02. Kit includes four 5" diameter, non-marking polyurethane casters with toe locks. Load rating for each caster is 250 pounds. Casters have bearings for quiet operation. Casters replace the fixed feet included with Telescoping Base Stands. **Installation is required.** Shipping weight 10 lbs. (4.5 kg)

# Electric & Manual Hydraulic Lift Base Stands

These stands have a built-in hydraulic lift so that height may be adjusted at any time. They allow you to position the stand and the safety cabinet or clean bench it supports to accommodate persons of different heights and wheelchair-bound users, to transport equipment through doorways, and for easier service access.



## Standard Features

- Support Purifier Delta Series Safety Cabinets and Purifier Horizontal Clean Benches.
- Support loads up to 1000 pounds.
- ADA-compliant.
- Durable 1.75" tubular, epoxy-coated steel frame with rear cross-bar supports. Sub-frame is 2.0" x 3.0".
- Height is infinitely adjustable from 25.5" to 33.5" high.
- Include four powder-coated, die-cast feet with levelers.
- NSF-Listed (115 volt Electric and Manual Lift models)
- Include front-accessible up/down switch (Electric Lift models)
- Include front-accessible hand crank. Turning the crank clockwise raises the stand; counterclockwise lowers it. The handle may be disengaged and folded under, out of the way, when not in use. (Manual Lift models)



Manual Hydraulic Lift Base Stand 3780304



## Caster Kit 3784000

Casters add mobility to the Hydraulic Lift Base Stand. Kit includes four 5" diameter, non-marking polyurethane casters with toe locks. Load rating for each caster is 250 pounds. Casters have bearings for quiet operation. Casters replace the fixed feet that are included with the stand. Installation is required. Not for use with stands that support hard-ducted enclosures such as Purifier Class II, Type B2 Safety Cabinets. Shipping weight 10 lbs. (4.5 kg)

### ELECTRIC LIFT

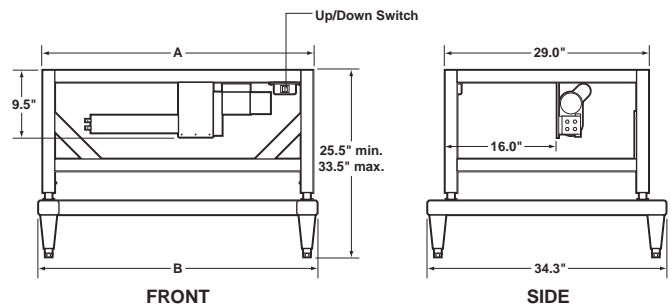

### MANUAL LIFT

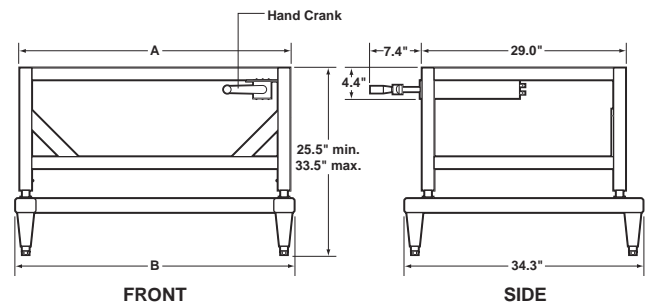

Model Numbers	A	B
3780300, 3780303, 3780400	36.0"	37.2"
3780100, 3780103, 3780200	38.5"	39.7"
3780301, 3780304, 3780401	48.0"	49.2"
3780101, 3780104, 3780201	50.5"	51.7"
3780302, 3780305, 3780402	72.0"	73.2"
3780302, 3780105, 3780202	74.5"	75.7"

# Electric & Manual Hydraulic Lift Base Stands

## Electric Hydraulic Lift Base Stands

Nominal Width	Catalog #	Overall Width x Depth	Switch Location	Electrical Requirements	Shipping Weight	For Use With:
3-Ft	3780300	36.0" w x 29.0" d	Right Side	115 volts, 60 Hz, 2.4 amps	100 lbs. (45 kg)	Purifier Horizontal Clean Bench, Purifier Forensics Enclosure, Purifier Trace Metals Work Station, Purifier Class 100 Chemical Stations
3-Ft	3780303*	36.0" w x 29.0" d	Right Side	230 volts, 50 Hz, 0.8 amp	100 lbs. (45 kg)	Purifier Horizontal Clean Bench, Purifier Forensics Enclosure, Purifier Trace Metals Work Station, Purifier Class 100 Chemical Station
3-Ft	3780100†	38.5" w x 29.0" d	Left Side	115 volts, 60 Hz, 2.4 amps	105 lbs. (48 kg)	Purifier Delta Series Safety Cabinet
3-Ft	3780103*	38.5" w x 29.0" d	Left Side	230 volts, 50 Hz, 0.8 amps	105 lbs. (48 kg)	Purifier Delta Series Safety Cabinet
4-Ft	3780301	48.0" w x 29.0" d	Right Side	115 volts, 60 Hz, 2.4 amps	120 lbs. (54 kg)	Purifier Horizontal Clean Bench
4-Ft	3780304*	48.0" w x 29.0" d	Right Side	230 volts, 50 Hz, 0.8 amps	120 lbs. (54 kg)	Purifier Horizontal Clean Bench
4-Ft	3780101†	50.5" w x 29.0" d	Left Side	115 volts, 60 Hz, 2.4 amps	125 lbs. (57 kg)	Purifier Delta Series Safety Cabinet
4-Ft	3780104	50.5" w x 29.0" d	Left Side	230 volts, 50 Hz, 0.8 amps	125 lbs. (57 kg)	Purifier Delta Series Safety Cabinet
6-Ft	3780302	72.0" w x 29.0" d	Right Side	115 volts, 60 Hz, 2.4 amps	150 lbs. (68 kg)	Purifier Horizontal Clean Bench
6-Ft	3780305*	72.0" w x 29.0" d	Right Side	230 volts, 50 Hz, 0.8 amps	150 lbs. (68 kg)	Purifier Horizontal Clean Bench
6-Ft	3780102†	74.5" w x 29.0" d	Left Side	115 volts, 60 Hz, 2.4 amps	155 lbs. (70 kg)	Purifier Delta Series Safety Cabinet
6-Ft	3780105*	74.5" w x 29.0" d	Left Side	230 volts, 50 Hz, 0.8 amps	155 lbs. (70 kg)	Purifier Delta Series Safety Cabinet

## Manual Hydraulic Lift Base Stands

Nominal Width	Catalog #	Overall Width x Depth	Handle Location	Shipping Weight	For Use With:
3-Ft	3780400	36.0" w x 29.0" d	Right Side	100 lbs. (45 kg)	Purifier Horizontal Clean Bench, Purifier Forensics Enclosure, Purifier Trace Metals Work Station, Purifier Class 100 Chemical Station
3-Ft	3780200†	38.5" w x 29.0" d	Left Side	105 lbs. (48 kg)	Purifier Delta Series Safety Cabinet
4-Ft	3780401	48.0" w x 29.0" d	Right Side	120 lbs. (54 kg)	Purifier Horizontal Clean Bench
4-Ft	3780201†	50.5" w x 29.0" d	Left Side	125 lbs. (57 kg)	Purifier Delta Series Safety Cabinet
6-Ft	3780402	72.0" w x 29.0" d	Right Side	150 lbs. (68 kg)	Purifier Horizontal Clean Bench
6-Ft	3780202†	74.5" w x 29.0" d	Left Side	155 lbs. (70 kg)	Purifier Delta Series Safety Cabinet

\* International electrical configuration

† NSF-Listed

# Seismic Base Stands

## SPECIFICATIONS & DIMENSIONS

### Standard Features

- Securely support Purifier Delta Series Class II, Type A2 and B2 Safety Cabinets in earthquake-prone regions.
- Sturdy and durable 2" tubular, epoxy-coated steel.
- Available in two fixed working heights, 30" and 36".
- Include four leveling feet.
- Include four epoxy-coated 0.25" thick steel seismic brackets to secure the Seismic Base Stand to the floor.



Seismic Base Stand 3770300.

Catalog #	Nominal Width	Overall Dimensions	Shipping Weight
3770300	3-Ft	38.5" w x 29.25" d x 28" high	90 lbs. (41 kg)
3770301	3-Ft	38.5" w x 29.25" d x 34" high	95 lbs. (43 kg)
3770400	4-Ft	50.5" w x 29.25" d x 28" high	118 lbs. (54 kg)
3770401	4-Ft	50.5" w x 29.25" d x 34" high	123 lbs. (56 kg)
3770600	6-Ft	74.5" w x 29.25" d x 28" high	157 lbs. (71 kg)
3770601	6-Ft	74.5" w x 29.25" d x 34" high	162 lbs. (73 kg)

Model #	A	B
3770300	38.5"	28"
3770301	38.5"	34"
3770400	50.5"	28"
3770401	50.5"	34"
3770600	74.5"	28"
3770601	74.5"	34"

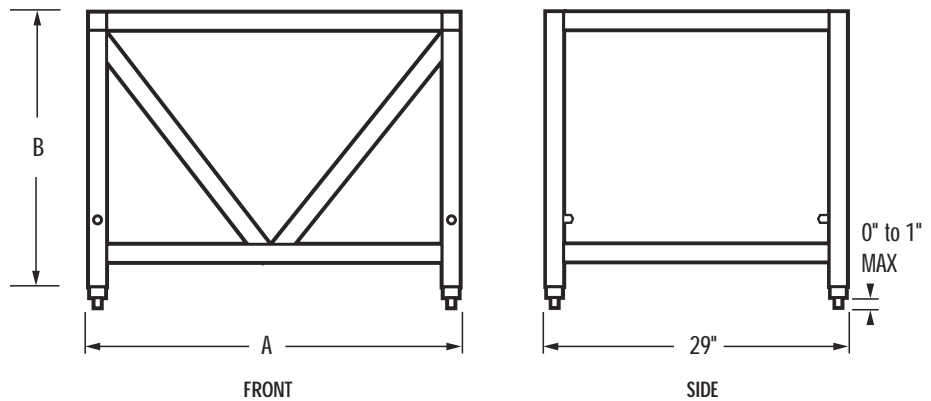

# Accessories

for Purifier® Delta® Series Class II, Type A2 Safety Cabinets

## Remote Blowers

Recommended when thimble-ducting the Purifier Delta Series Class II, Type A2 Safety Cabinets. Helps to remove exhausted air from the ductwork to the outside. Motor is TEFC (totally enclosed fan cooled). Belt-drive blower has an adjustable sheave and self-adjusting gravity belt tightener. Impeller is phenolic-coated steel. Blower has a dry-powder epoxy-coated base and weathercover. An integral damper prevents backdrafts from flowing down through the ductwork, disrupting airflow within the cabinet. Includes a blower transition adapter with 10.875" ID inlet sized to accept 10" nominal diameter PVC duct and outlet sized to accept 8" nominal diameter PVC duct. Dimensions: 22.81" w x 17.13" d x 22.38" high (57.9 x 43.5 x 56.8 cm). See dimensional details on page 64. Shipping weight 93 lbs. (42 kg)



Catalog #	For use with:	HP	CFM@Static Pressure Loss	Electrical Requirements	Shipping Weight
3668000	3-Ft and 4-Ft Purifier	1/4	555 @ 0.25" to 448 @ 0.5"	115 volts, 1 ø, 60 Hz, 4.4 amps	93 lbs. (42 kg)
3668001	6-Ft Purifier	1/2	760 @ 0.25" to 700 @ 0.5"	115 volts, 1 ø, 60 Hz, 8.4 amps	99 lbs. (45 kg)

## Canopy Connection Kits

Thimble-ducting expands the use of the Class II, Type A2 safety cabinets to include malodorous samples, small amounts of volatile toxic chemicals and tracer quantities of radionuclides. The Canopy Connection Kits allow the Purifier Delta Series Class II, Type A2 Safety Cabinets to be thimble-ducted to the outside with minimal disturbance to the cabinet airflow. The canopy provides an air gap to allow room air to enter the ductwork and mix with the filtered air being exhausted to the outside. Each Kit includes an epoxy-coated steel exhaust transition adapter, hardware necessary to install the adapter and installation instructions. Outlet is 10" ID and accepts 10" nominal diameter ductwork such as the Air-Tight Damper 3776800, which is sold separately. Remote Blower 3668000 or 3668001 is recommended (not included). Shipping weight 13 lbs. (5.9 kg)

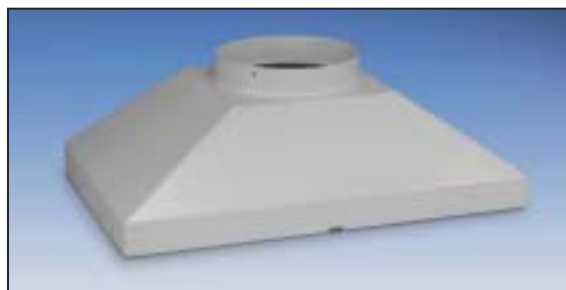

Contact Labconco for ordering information on Canopy Connection Kits for Purifier Delta Series Safety Cabinets manufactured prior to October 2003.

Catalog #	For use with:	Model Series	Total Exhaust Volume (Safety Cabinet and Room Air)
3794400	3-Ft Purifier Delta Series Class II, Type A2 Cabinets	36204	303-334 CFM
		36205	244-268 CFM
3794500	4-Ft Purifier Delta Series Class II, Type A2 Cabinets	36208	404-444 CFM
		36209	323-355 CFM
3794600	6-Ft Purifier Delta Series Class II, Type A2 Cabinets	36212	654-720 CFM
		36213	524-576 CFM

## 3776800 Air-Tight Damper

Manual adjustable damper may be permanently fastened directly atop the Canopy Connection Kit to provide a transition to exhaust ductwork and means to control the exhaust airflow. The damper may be adjusted to help minimize the amount of conditioned air being exhausted from the room. During cabinet decontamination procedures, a certified technician may close the damper to provide an air-tight seal. Type 304 stainless steel. 10" high with 10" OD inlet and outlet. Shipping weight 13 lbs. (5.9 kg)



# Remote Blower

for Purifier® Delta Series Total Exhaust Safety Cabinets

## 3663500 Remote Blower

A remote blower is required for operation of the Purifier Delta Series Class II, Type B2 Total Exhaust Safety Cabinet. The 2 hp motor is TEFC (totally enclosed fan cooled) and delivers up to 1179 CFM at 3.98" static pressure loss. Belt-drive blower has an adjustable sheave and self-adjusting gravity belt tightener. Impeller is phenolic-coated steel. Blower has a dry-powder epoxy-coated base and weathercover. An integral damper prevents backdrafts from flowing down through the ductwork, disrupting airflow within the cabinet. Blower inlet is 12.25" ID and is sized to accept 12" nominal diameter PVC duct. Includes a blower transition adapter outlet sized to accept 12" nominal diameter PVC duct. For operation on 230/460 volts, 3 phase, 60 Hz, 5.8/2.9 amps AC. Dimensions: 24.31" w x 21.5" d x 22.38" high (61.8 x 54.6 x 56.8 cm). See dimensional details below. Shipping weight 100 lbs. (45 kg)



### Dimensions for Remote Blowers 3668000, 3668001 and 3663500

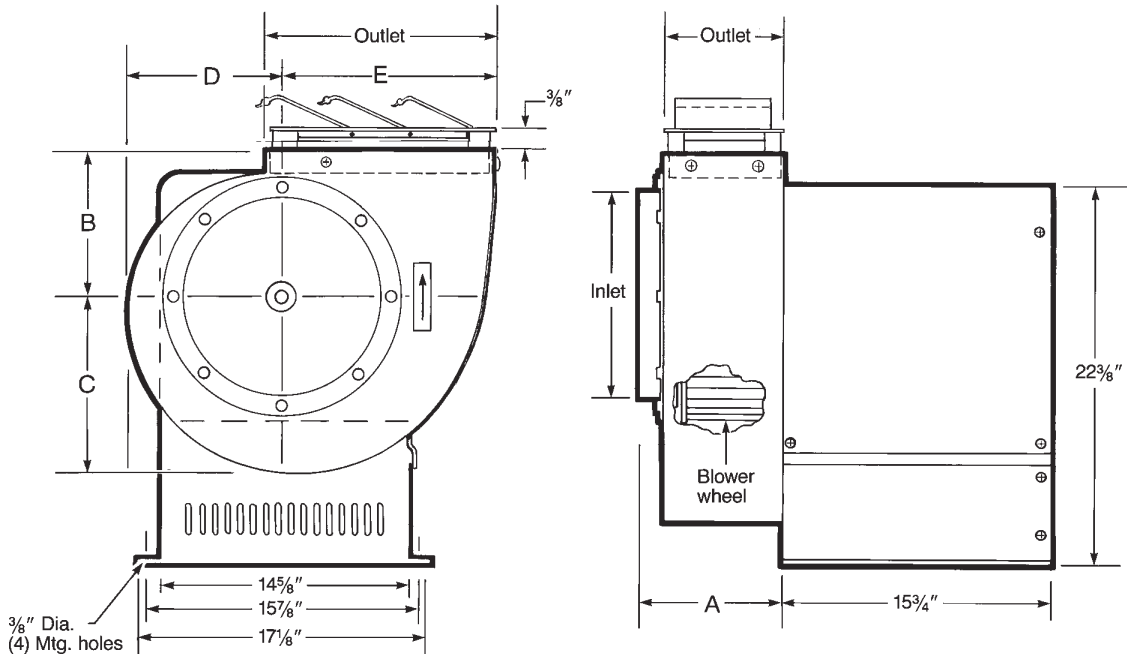

	3668000 & 3668001	3663500
A	7.0625"	8.5625"
B	7"	9"
C	8.125"	10.5"
D	6.8125"	9"
E	9.25"	12.25"
Inlet	10.875"	12.25"
Outlet	5.5" x 10" OD	7" x 13.5" OD
Blower Wheel	9.1875" dia. x 4.25" w	12.1875" x 5.25" w

# Remote Blowers

for Purifier® Class I & HEPA Filtered Enclosures & PVC Total Exhaust Clean Benches



## Remote Blowers for Hard-Ducted Purifier Class I and HEPA Filtered Enclosures

A remote blower is required when hard-ducting the Purifier Class I Safety Enclosure or Purifier HEPA Filtered Enclosure. The direct drive blower has a 1/4 hp TEFC-type motor and overcomes external static pressure of 0.5" at 230 CFM. Housing and impeller are corrosion-resistant epoxy-coated steel. An integral damper prevents backdrafts from flowing down through the ductwork, disrupting airflow within the cabinet. Blower inlet is 5.94" OD and is sized to accept 6" nominal diameter PVC duct. Includes a blower transition adapter outlet sized to accept 6" nominal diameter PVC duct. Dimensions: 14.6" w x 13.5" d x 23.75" high (37.1 x 34.3 x 60.3 cm). See dimensional details below.



## Fiberglass Blower for Use with PVC Total Exhaust Clean Benches

A remote blower is required to hard-duct the Purifier Trace Metals Work Station, Purifier Forensic Enclosure or the Purifier Class 100 Chemical Station. The 1/3 hp motor is TEFC-type and delivers up to 490 CFM at .88" static pressure. The Fiberglass Blower provides superior corrosion resistance to chemical fumes. The housing is durable molded fiberglass reinforced polyester. The impeller is molded polypropylene. Belt-drive blower has an adjustable sheave and self-adjusting gravity belt tightener. Blower has a dry-powder epoxy-coated base and weathercover. Blower inlet is 10.375" OD and is sized to accept 10" nominal diameter PVC duct. Blower outlet is 10.75" ID and is sized to accept 10" nominal diameter PVC duct. Dimensions: 26.5" w x 22.6 x 27.8" high (67.3 x 57.4 x 70.6 cm). See dimension details below.

Catalog #	For use with:	Electrical Requirements	Shipping Weight
3716000	3720000, 3720001 3730000, 3730001	115 volts, 60 Hz, 4.4 amps	36 lbs. (16.3 kg)
3716001	3720020, 3720021 3730020, 3730021	115 volts, 60 Hz, 1.5 amps 230 volts, 50 Hz, 2.8 amps	36 lbs. (16.3 kg)

Catalog #	For use with:	Electrical Requirements	Shipping Weight
7180400	3750003, 3750004 3750005	115 volts, 1 phase, 60 Hz, 5.4 amps	86 lbs. (39 kg)

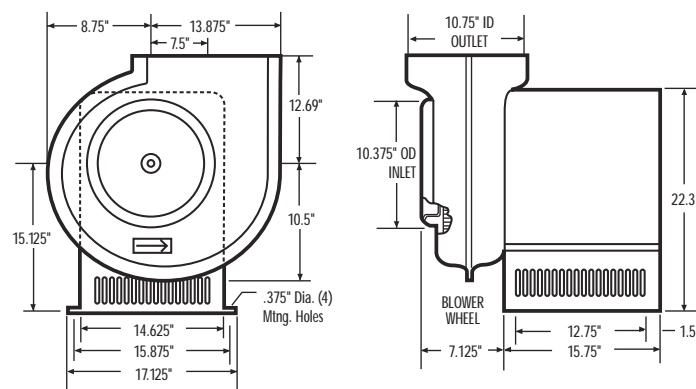
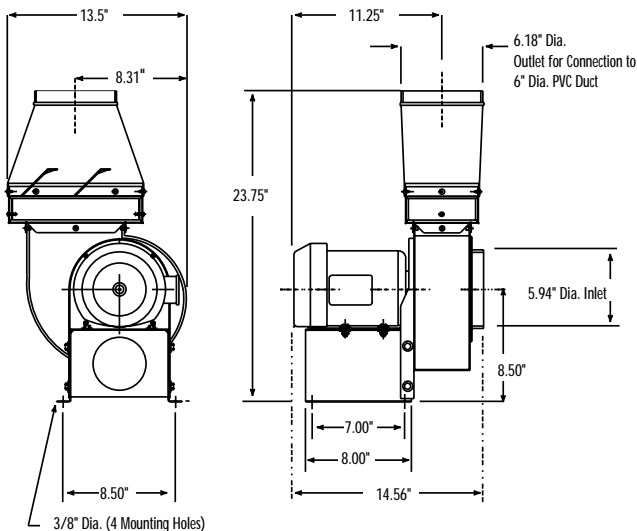

# Purifier® Delta® Series Class II, Type A2 Safety Cabinets

## DIMENSIONS

**36204 and 36205 Series**

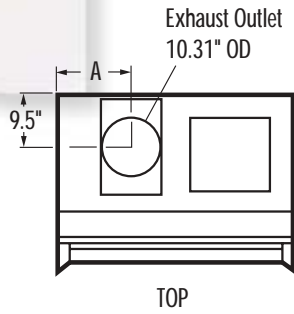

**36208 and 36209 Series**

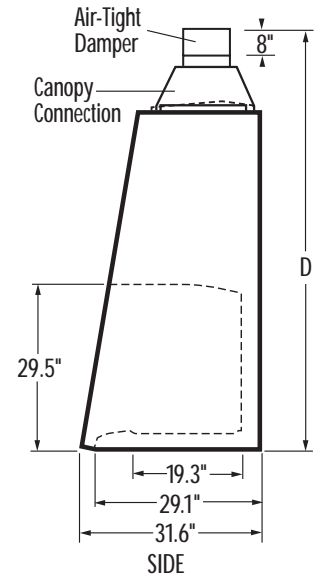
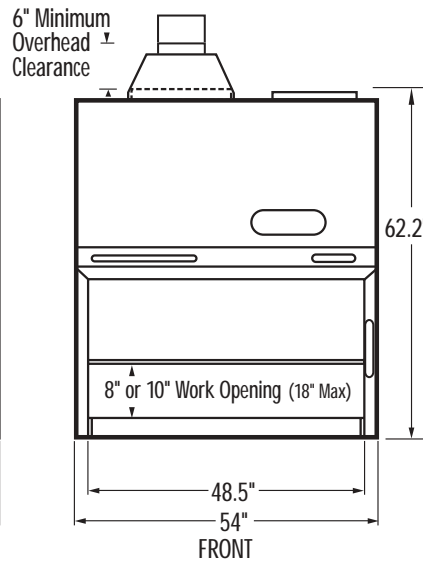
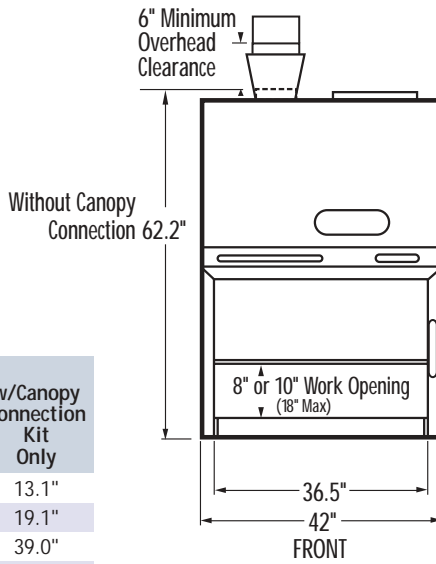
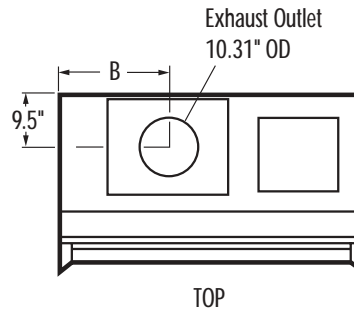

	w/Canopy Connection Kit and Gas-Tight Damper	w/Canopy Connection Kit Only
A	13.1"	13.1"
B	19.1"	19.1"
C	39.0"	39.0"
D	78.7"	70.7"

**36212 and 36213 Series**

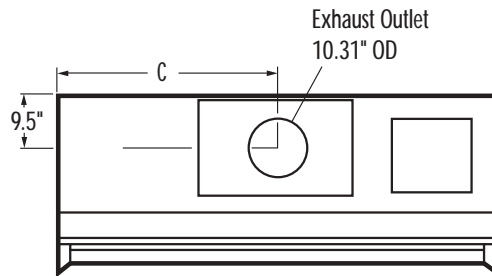

*Dotted line represents exhaust air diffuser, used when cabinet is not thimble-ducted to the outside.*

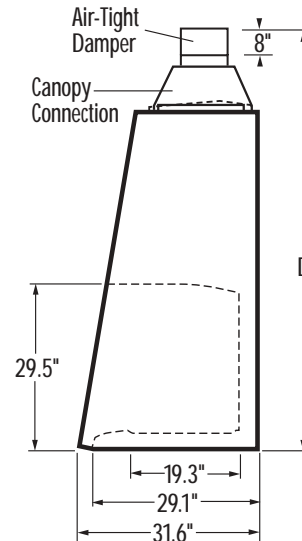
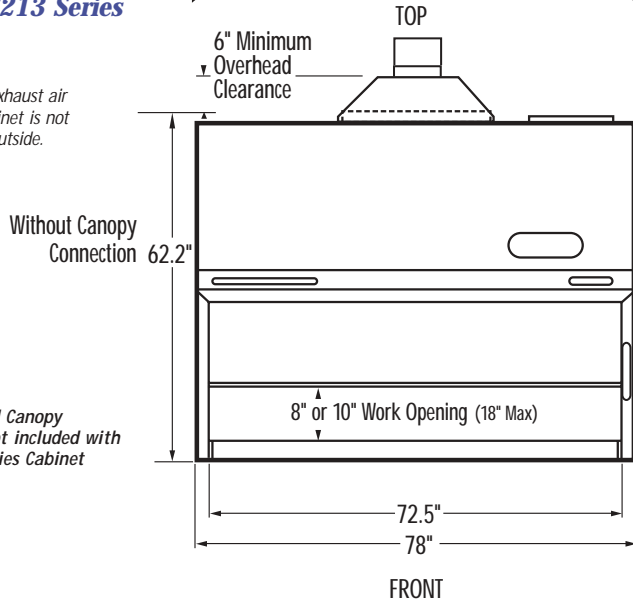

*Air-Tight Damper and Canopy Connection Kit are not included with the Purifier Delta Series Cabinet*

# Purifier® Delta® Series Total Exhaust Safety Cabinets

## D I M E N S I O N S

### 36210 Series

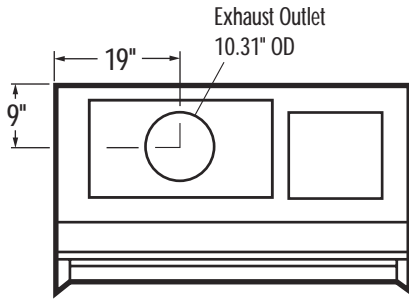

TOP

### 36214 Series

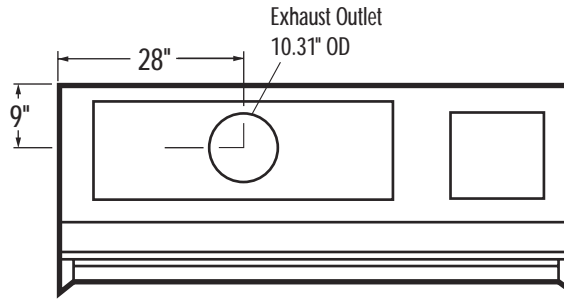

TOP

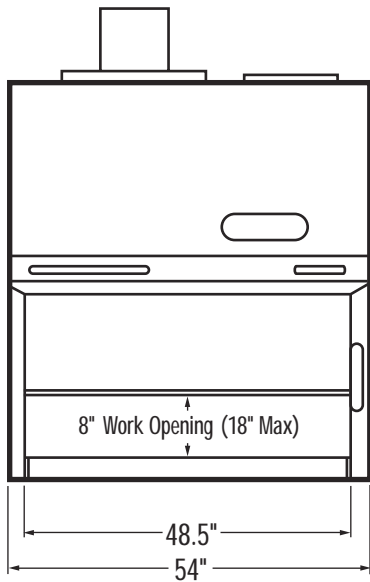

FRONT

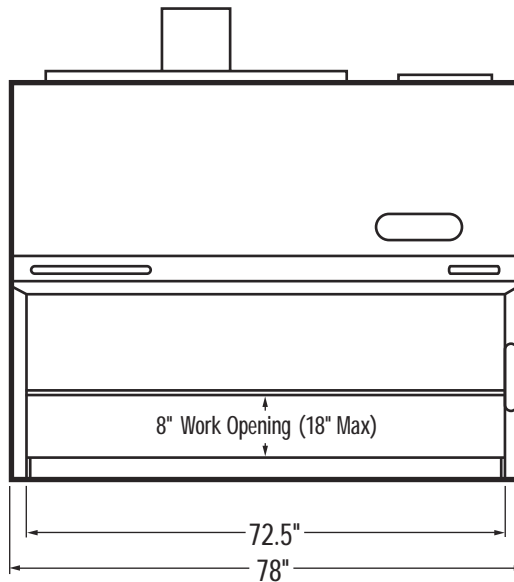

FRONT

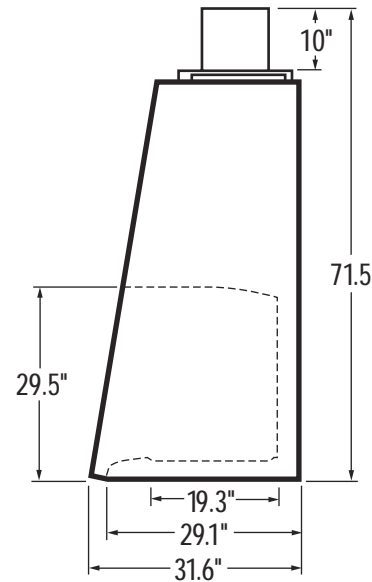

SIDE

# Biological Safety Cabinets, Enclosures & Clean Benches

## DIMENSIONS

TOP

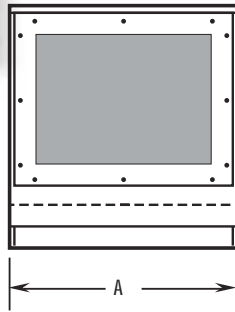

**Purifier PCR Enclosures**  
**Purifier Vertical Clean Benches**

	2-Foot	3-Foot
A	23.75"	35.75"
B	22.625"	34.625"

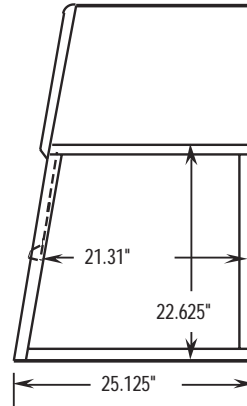
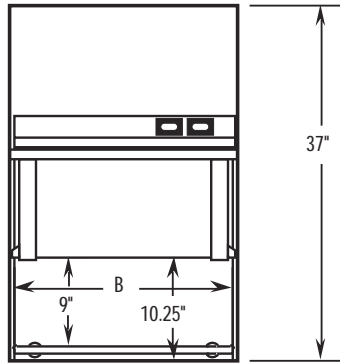

FRONT

SIDE

TOP

Prefilters:  
2 each on  
3' and 4' models,  
3 each on  
6' models

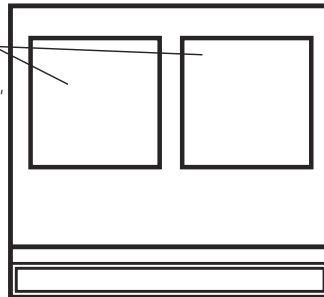

**Purifier Horizontal Clean Benches**

	3-Foot	4-Foot	6-Foot
A	38.25"	50.25"	74.25"
B	37"	49"	73"

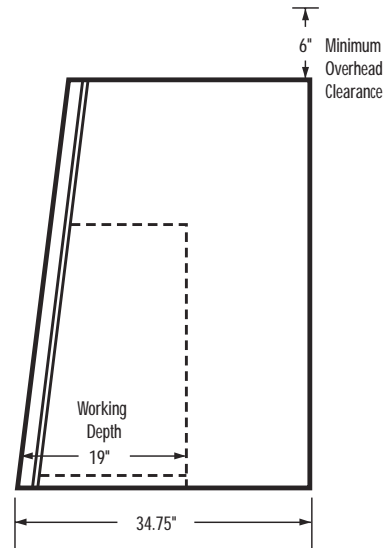
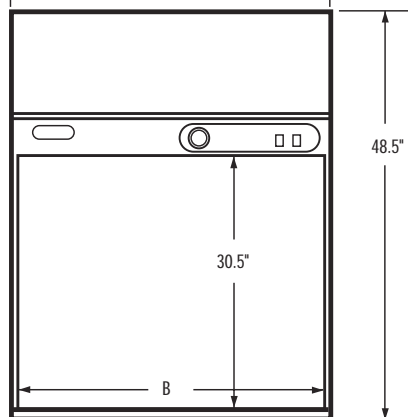

FRONT

SIDE

# Biological Safety Cabinets, Enclosures & Clean Benches

## GLOSSARY

**absolute filter:** Obsolete term for HEPA filter.

**aerosol:** A colloid of liquid or solid particles suspended in a gas, usually air.

**agent:** Any biological, chemical or physical power, principle or substance capable of acting upon a subject organism, usually to its detriment.

**air barrier ("air curtain"):** The unidirectional movement of air past and parallel to the plane of an opening and at a velocity greater than that on either side, thereby creating an impedence to transverse movement of airborne particulates through the opening.

**air stream:** A current of air; airflow.

**antiseptic:** A compound that prevents the multiplication of microorganisms. Bacteriostatic in action, not bactericidal. Its use applies to tissues rather than inanimate surfaces.

**aseptic technique:** The performance of a procedure or operation in a manner that prevents the introduction of microorganisms which are capable of causing infection or contamination.

**assessment of risk:** The process of defining biological hazard associated with a microbial or antigenic entity.

**biohazard:** A contraction of the words biological and hazard; infectious agent(s) presenting a real or potential risk to the well-being of man, other animals, or plants, either directly through infection or indirectly through disruption of the environment.

**biohazard cabinet:** See biological safety cabinet.

**biological challenge:** A series of tests performed to assure that aerosols are contained within the cabinet, that outside contaminants do not enter the cabinet, and contaminants in the cabinet remain localized. Suspensions of *Bacillus subtilis* subsp. *niger* spores are used as an indicator in the tests.

**biological safety cabinet:** Cabinet intended to protect the user and environment from the hazards of handling infectious material and other biohazardous material. Some types may also protect the materials being handled in them from contamination.

**Brownian motion:** A random movement of microscopic particles suspended in liquids or gases resulting from impact of the molecules of the suspending agent on the particles.

**canopy connection:** A biohazard cabinet exhaust system with a physical gap or space between the cabinet's exhaust and the exhaust system intake. During operation, the exhaust system draws all of the cabinet's exhaust air through the duct, plus a small volume of room air through the gap.

**certification:** When pertaining to safety cabinets, measurement and/or correction of safety cabinet air velocities, patterns, balance, leakage and filtration system by a qualified technician.

**chemical carcinogen:** Those chemicals designated as posing a potential occupational carcinogenic risk to workers by OSHA or the Department of Health and Human Services Committee for Coordinating Toxicology and Related Programs.

**clean room:** A dust-free facility.

**collection efficiency:** Usually expressed as the percentage of material collected compared with the total amount present, it may be calculated on a particle number basis or a total weight basis.

**contamination:** Any foreign substance which makes an unwanted incursion. In the present context, usually viable airborne particulates.

**decontamination:** The destruction or removal of living organisms (this does not imply either total destruction or total removal), or the removal or neutralization of toxic agents or chemical carcinogens; to make an object safe for unprotected individuals.

**di- (2 ethyl hexyl) phthalate:** See DOP.

**di-sec-octyl phthalate:** See DOP.

**diffuser:** A device, often a screen, used to distribute airflow evenly.

**diffusion:** A phenomenon of HEPA filtration by which Brownian motion causes particles to diffuse across airstream lines impacting them on a filter fiber.

**dioctyl phthalate:** See DOP.

**disinfectant:** A chemical agent that kills or inactivates vegetative bacteria, fungi, and viruses, but not necessarily spores. This term applies to inanimate surfaces as opposed to tissues.

**DOP:** Dioctylphthalate, an oil that can be aerosolized to an extremely uniform size; i.e. 0.3  $\mu\text{m}$  for a major portion of any sample; the aerosol is used to challenge HEPA filters.

**hot DOP:** Produced by controlled vaporization and condensation of liquid DOP to give a cloud of monodisperse droplets with diameters of approximately 0.3  $\mu\text{m}$ .

**cold DOP:** Produced by compressed air atomization of room temperature liquid DOP, aerosol size 0.3 to 3.0  $\mu\text{m}$  with a mean diameter of 0.7  $\mu\text{m}$ .

**downstream:** In the direction of the flow.

**droplet:** An airborne particle consisting primarily of liquid. While some settle out quickly, many dry to become droplet nuclei and can add significant numbers of microorganisms to the air.

**exhaust:** The withdrawing and expelling of air from the cabinet by means of a blower or fan; that portion of the cabinet air that is discharged after filtration, either to the room or into a ventilation system.

**filter:** A device used for removal of particulates, including microorganisms, from air or other gases. (Also see HEPA filter.)

**filter efficiency:** The efficiency of various filters can be established on the basis of entrapped particles, i.e., collection efficiency; or on the basis of particles passed through the filter, i.e., penetration efficiency.

**germicidal:** Able to destroy bacteria, fungi, viruses and other similar organisms.

**hard-ducting:** Permanently installed airtight ductwork not intended to be disassembled for normal cabinet servicing or testing.

**HEPA filter:** High-efficiency particulate air filter. A disposable extended-pleated dry-type filter with (1) a rigid casing enclosing the full depth of the pleats; (2) a minimum particle removal efficiency of 99.9% for thermally generated monodisperse DOP smoke particles with a diameter of 0.3  $\mu\text{m}$ ; and (3) a maximum pressure drop of 1 inch water gauge when clean and operated at its rated airflow capacity.

**high efficiency particulate air filter:** See HEPA filter.

**horizontal laminar flow bench:** A ventilated cubicle with solid sides having a table-height work surface and unidirectional, minimum turbulence air entering from a vertically mounted high efficiency filter at one side and leaving the cubicle at the opposite (open) side.

# Biological Safety Cabinets, Enclosures & Clean Benches

## GLOSSARY & REFERENCES

**inches of water gauge (in w.g.):** A unit of pressure equal to the weight of a column of liquid water one inch high at 20°C (1 in. w.g.= 0.036 psi).

**infectious agent:** As used in this text, agents capable of producing a disease or abnormal response in man, laboratory animals, or a tissue culture system.

**inflow velocity:** Air velocity at the cabinet work opening; velocity of the air entering the cabinet at the work opening.

**laminar airflow:** Airflow in which the entire body of air within a designated space moves with uniform velocity along parallel flow lines.

**monodisperse aerosol:** An aerosol containing particles of nearly the same size.

**negative pressure:** Pressure in a space which causes an inflow of air.

**partial containment enclosure:** An enclosure which is constructed so that contamination between its interior and the surroundings is minimized by the controlled movement of air. Class I and Class II safety cabinets are examples.

**plenum:** An enclosure for flowing gases in which the static pressure at all points is relatively uniform.

**positive pressure:** Pressure in a space which causes an outflow of air.

**protection:** In Class II cabinets, any aerosol generated is kept away from the technician doing the work.

**environmental protection:** Any aerosol generated within the cabinet is removed from the air or deactivated (such as by incineration) before the air from the cabinet is discharged either inside or outside the facility.

**personnel protection:** Any aerosol generated within the cabinet is kept away from the technician doing the work.

**product protection:** The air at the work surface of the cabinet has been filtered so that it is free of airborne particles and organisms which could contaminate the work.

**static pressure:** The pressure of a fluid exerted in all directions equal and opposite to the pressure tending to compress the fluid. In ventilation applications, static pressure is usually the difference between the absolute pressure in an exhaust system and atmospheric pressure.

**sterile:** The absence of all life on or in an object. This is an absolute term; there can be no such description as nearly sterile, partially sterile, etc.

**sterilize:** Any process, physical or chemical, which results in the absence of all life in an object, applied especially to microorganisms, including bacteria, fungi, and their spores and the inactivation of viruses.

**supply air:** Air entering the cabinet through the work opening to make up for the volume of air exhausted.

**thimble connection:** See canopy connection.

**ultraviolet (UV) light:** Radiation in the electromagnetic spectrum having wavelengths from approximately 200 to 390 nanometers.

**velocity:** The time rate of linear motion in a given direction.

**capture and/or containment velocity:** The velocity necessary to capture or contain a generated contaminant, in a cabinet this usually ranges from 50 to 200 fpm.

**viable:** Literally, capable of life. Generally refers to the ability of microbial cells to grow and multiply as evidenced by formation of

colonies on an agar culture medium; or, as with viruses, to divert the host cell's metabolism to replication of the parasite.

**virus:** A parasitic microorganism, smaller than a bacterium. Viruses have no independent metabolic activity, and may replicate only within a cell of a living plant or animal host.

*Portions of glossary taken from First, Melvin et al., Student Manual: Testing of Class II Biological Safety Cabinets, 1986. Dept. of Environmental Health Science, Harvard School of Public Health, Boston, MA*

### References and Web Sites

American Biological Safety Association  
<http://www.absa.org>

"ASHP technical assistance bulletin on handling cytotoxic and hazardous drugs." *American Journal of Hospital Pharmacy*, May 1990, 47, 1033-104.  
<http://www.ashp.org>

CDC Office of Health and Safety Information System  
<http://www.cdc.gov/od/ohs>

European Biosafety Association  
<http://www.ebsa.be>

Fleming, Diane O. & Debra L. Hunt, Editors. *Biological Safety: Principles and Practices*. 3rd Edition. ASM Press, Washington, D.C. American Society for Microbiology, 2000.  
<http://www.asm.org>

*Guidelines for the Safe Transport of Infectious Substances and Diagnostic Specimens*. Geneva, Switzerland: World Health Organization Division of Emerging and Other Communicable Diseases Surveillance and Control, 1997.  
<http://www.who.int/emc/biosafety.html>

*NSF International Standard Number 49 for Class II (Laminar Flow) Biohazard Cabinetry*. Ann Arbor, Michigan, 2002.  
[http://www.nsf.org/biohazard/bio\\_standards.html](http://www.nsf.org/biohazard/bio_standards.html)

*Occupational Exposure to Bloodborne Pathogens. – 1910.1030*. OSHA Regulation (Standards – 29 CFR). Occupational Health and Safety, U.S. Department of Labor.  
<http://www.osha-slc.gov>

Richmond, Jonathan Y, Ph.D. and McKinney, Robert, Ph.D, Editors. *CDC-NIH: Primary Containment for Biohazards: Selection, Installation and Use of Biological Safety Cabinets*. 2nd Edition. Bethesda, Maryland: U.S. Department of Health and Human Services Public Health Service, Centers for Disease Control and Prevention, and National Institutes of Health, September 2000.  
<http://www.cdc.gov/od/ohs/biosfty/bsc/bsc.htm>

Richmond, Jonathan Y, Ph.D. and McKinney, Robert, Ph.D, Editors. *CDC-NIH Biosafety in Microbiological and Biomedical Laboratories*. HHS Publication No. (CDC) (99-8395). 4th Edition. Washington, DC: U.S. Department of Health and Human Services Public Health Service, Centers for Disease Control and Prevention and National Institutes of Health. U.S. Government Printing Office, April 1999.  
<http://www.cdc.gov/od/ohs/biosfty/bmb14/bmb14toc.htm>

*The Laboratory Biosafety Guidelines*. 2nd Edition. Canada: Health Protection Branch – Laboratory Centre for Disease Control, 1996.  
<http://www.hc-sc.gc.ca>

# Biological Safety Cabinets, Enclosures & Clean Benches

## INDEX

Catalog #	Page	Catalog #	Page
3740001	55	3745500	24
3600000	55	3745501	24, 31
3600020	55	3745502	24, 31
3600024	55	3746000	18, 24, 31, 36, 42, 44, 47, 51, 56
3610000	55	3746701	38, 42, 58, 59
3610004	55	3746702	52, 58, 59
3610020	55	3746704	58
3610024	55	3746711	58, 59
3612500	55	3746712	58, 59
3612504	52, 55	3746714	58, 59
3612520	55	3747000	44, 48, 58, 59
3612524	55	3747001	32, 58, 59
3618000	56	3747002	58
3620400	23	3747010	58, 59
3620404	12, 22, 23	3747011	58, 59
3620500	23	3747012	58
3620504	23	3747500	24, 31
3620510	23	3750000	51
3620514	23	3750001	51
3620520	23	3750002	47
3620524	23	3750003	38, 42
3620800	23	3750004	42
3620804	23	3750005	42
3620900	23	3750020	51
3620904	23	3750021	51
3620910	23	3750022	47
3620914	23	3768900	56
3620920	23	3768901	56
3620924	23	3770300	62
3620930	23	3770301	62
3620934	23	3770400	62
3621000	30	3770401	62
3621004	30	3770600	62
3621010	30	3770601	62
3621014	30	3773700	56
3621020	30	3773800	56
3621024	30	3773801	56
3621200	23	3773802	56
3621204	23	3776800	24, 63
3621300	23	3780100	60
3621304	23	3780101	60, 61
3621310	23	3780102	61
3621314	23	3780103	60
3621320	23	3780103	61
3621324	23	3780104	60, 61
3621400	30	3780105	60, 61
3621404	26, 30	3780200	12, 60, 61
3621410	30	3780201	60, 61
3621414	30	3780202	60, 61
3663500	31, 64	3780300	60, 61
3668000	24, 63, 64	3780301	60, 61
3668001	24, 63, 64	3780302	60, 61
3680404	18	3780303	60, 61
3697500	56	3780304	60, 61
3715000	37	3780305	60, 61
3715001	37	3780400	60, 61
3716000	37, 65	3780401	60, 61
3716001	37, 65	3780402	60, 61
3718000	47, 51	3784000	12
3718001	47, 51	3794400	24, 63
3720000	36	3794500	24, 63
3720001	35	3794600	24, 63
3720020	36	4708600	37
3720021	35	4708700	37
3721000	51	4708900	37
3721001	51	4718900	25, 43
3727500	43	4719000	43
3728100	43	4719200	25, 43
3730000	36	4719900	43
3730001	32, 35	4722200	37
3730020	36	4722300	25
3730021	35	4861800	37
3730300	22, 58, 59	4862100	36, 44, 47, 48, 51
3730310	58, 59	4863100	32, 36, 47, 51
3730400	18, 58, 59	5602000	25
3730410	58, 59	5602100	25
3730500	59	5606000	43
3730600	26, 30, 58, 59	5606100	25
3730610	58, 59	5621400	25
3740000	48, 51	5622100	25
3740001	51	7027200	25, 43
3740002	44, 47	7027300	25
3740020	51	7027500	43
3740021	51	7027800	25
3740022	47	7034200	25, 43
3744000	12, 18, 24, 26, 31, 32, 37, 38, 42, 47, 48, 51, 52, 56	7067300	25
3745000	24, 31	7095100	25, 43
3745001	24, 31	7180400	43, 65
		8022000	18, 24, 31, 57

**Contact Labconco for more information about these quality products for your laboratory.**



Fume Hoods and Carbon-Filtered Enclosures



Glove Boxes



Laboratory Animal Research Stations



Water Purification Systems



Glassware Washers

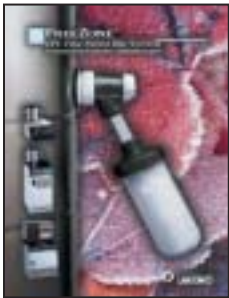

Freeze Dry Systems



Centrifugal Concentrators and Cold Traps



Multiple Sample Evaporation Systems

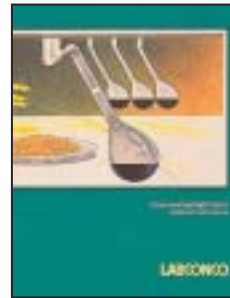

Agricultural Chemistry Products



Laboratory Carts and Benches



Blood Drawing Chairs



Digital Chlorodometers



Vacuum Desiccator

For more information, please contact us:

ExpotechUSA

10700 Rockley Road  
Houston, Texas 77099  
USA

281-496-0900 [voice]

281-496-0400 [fax]

E-mail: sales@expotechusa.com

Website: www.ExpotechUSA.com