



User's Manual

Protector[®] PVC Perchloric Acid & Acid Digestion Laboratory Fume Hoods

Perchloric Acid Models

4882300

7282300

9682300

Acid Digestion Models

4882400

7282400

9682400



Labconco's Mascot,
Labby the LABster



*Protecting your
laboratory environment*

LABCONCO[®]

For more information, please contact us:

ExpotechUSA

10700 Rockley Road
Houston, Texas 77099
USA

281-496-0900 [voice]

281-496-0400 [fax]

E-mail: sales@expotechusa.com

Website: www.ExpotechUSA.com

Warranty

Labconco provides a warranty on all parts and factory workmanship. The warranty includes areas of defective material and workmanship, provided such defect results from normal and proper use of the equipment.

The warranty for all Labconco products will expire one year from date of installation or two years from date of shipment from Labconco, whichever is sooner, except the following:

- Purifier® Delta® Series Biological Safety Cabinets carry a three-year warranty from date of installation or four years from date of shipment from Labconco, whichever is sooner.
- Carts carry a lifetime warranty.
- Glass is not warranted from breakage due to accident or mishandling.

This limited warranty covers parts and labor, but not transportation and insurance charges. In the event of a warranty claim, contact Labconco Corporation or the dealer who sold you the product. If the cause is determined to be a manufacturing fault, the dealer or Labconco Corporation will repair or replace all defective parts to restore the unit to operation. Under no circumstances shall Labconco Corporation be liable for indirect, consequential, or special damages of any kind. This statement may be altered by a specific published amendment. No individual has authorization to alter the provisions of this warranty policy or its amendments. Lamps and filters are not covered by this warranty. Damage due to corrosion or accidental breakage is also not covered.

Limitation of Liability

The disposal and/or emission of substances used in connection with this equipment may be governed by various federal, state, or local regulations. All users of this equipment are required to become familiar with any regulations that apply in the user's area concerning the dumping of waste materials in or upon water, land, or air and to comply with such regulations. Labconco Corporation is held harmless with respect to user's compliance with such regulations.

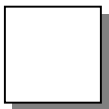

Part #98580 Rev A, ECO B483

Product designs are subject to change without notice

TABLE OF CONTENTS

CHAPTER 1: INTRODUCTION	1
About This Manual	3
Typographical Conventions	4
Your Next Step	5
CHAPTER 2: PREREQUISITES	7
Location Requirements	8
Support Requirements	8
Exhaust Requirements	8
Exhaust Requirements Table	9
Exhaust Washdown Requirements	9
Electrical Requirements	10
Service Line Requirements	10
Space Requirements	10
Your Next Step	10
CHAPTER 3: GETTING STARTED	11
Unpacking Your PVC Fume Hood	12
Removing the Shipping Skid	13
Sash Weight Release	13
Install PVC Hood on Support Structure & Hardboard Support	14
Connecting to Protector PVC Hood Exhaust System	17
Connecting to the Exhaust Washdown	18
Connecting to the Washdown Drain	18
Connecting the Electrical Supply Source to the PVC Fume Hood	19
Connecting the Service Lines to the PVC Fume Hood	21
Connecting the Washdown Control Fixture to the PVC Fume Hood	22
Certifying the PVC Fume Hoods	22
Your Next Step	23
CHAPTER 4: PERFORMANCE FEATURES AND SAFETY	
PRECAUTIONS	25
Performance Features	25
Safety Precautions	31

Your Next Step	35
CHAPTER 5: USING THE PVC FUME HOOD	37
Operating the Vertical-Rising Glass Sash	37
Operating the Vertical-Rising Lexan Sash	38
Operating the Blower	38
Operating the Lights	38
Operating the Washdown Control Valve	38
Working in the Protector PVC Fume Hood	39
Your Next Step	41
CHAPTER 6: MAINTAINING THE PVC FUME HOOD	43
Routine Maintenance Schedule	44
Routine Service Operations	45
Your Next Step	45
CHAPTER 7: MODIFYING THE PVC FUME HOOD	47
Installing Hardboard Support	47
Installing Ceiling Enclosures above the PVC Fume Hood	48
Installing Rear Panels Behind the Fume Hood	48
Installing Additional Service Fixtures	49
Installing Guardian Digital Airflow Monitor or Guardian Jr.	49
Sash Stop Kit – Field Installation	50
Installing an Electrical Duplex Outlet	50
Your Next Step	51
CHAPTER 8: TROUBLESHOOTING	53
APPENDIX A: PROTECTOR PVC HOOD COMPONENTS	57
APPENDIX B: PROTECTOR PVC HOOD DIMENSIONS	61
APPENDIX C: PROTECTOR PVC HOOD SPECIFICATIONS	63
APPENDIX D: REFERENCES	69
DECLARATION OF CONFORMITY	73

CHAPTER 1

INTRODUCTION

Congratulations on your purchase of a Labconco Protector® PVC Perchloric Acid Laboratory Fume Hood or Protector® PVC Acid Digestion Laboratory Hood. The difference between the two hoods is that the Protector PVC Perchloric Acid Hood uses a glass sash and the Protector PVC Acid Digestion Hood uses a Lexan™ sash to combat the fogging of glass caused by hydrofluoric acid (HF). Note that Perchloric acid will react with the Lexan sash and is not to be used in an Acid Digestion Hood. The Protector PVC Perchloric Laboratory Hood is designed to efficiently ventilate procedures using Perchloric acid. The Protector PVC Acid Digestion Laboratory Hood is designed to efficiently ventilate all other heavy acid operations including hydrofluoric acid. It is the result of Labconco's more than 50 years experience in manufacturing fume hoods, and users like you suggested many of its features to us.

The Protector PVC Perchloric Acid Fume Hood has been engineered to provide maximum safety in a laboratory while using Perchloric acid. **Usage of materials other than Perchloric acid is not recommended. Perchloric acid is a strong oxidizing agent, and should not be used in combination with any organic material as the possibility of a hazardous chemical reaction or explosion could develop.** The Protector PVC Acid Digestion Fume Hood has been designed to handle all other

types of acids including hydrofluoric acid (HF), but not Perchloric acid. The Protector PVC Hoods offer many unique features to enhance safety, performance, and visibility.

To take full advantage of them, please acquaint yourself with this manual and keep it handy for future reference. If you are unfamiliar with how fume hoods operate, please review *Chapter 4: Performance Features and Safety Precautions* before you begin working in the fume hood. Even if you are an experienced fume hood user, please review *Chapter 5: Using Your Fume Hood*, which describes the Protector PVC Perchloric Acid Hood features so that you can use the hood efficiently.

About This Manual

This manual is designed to help you learn how to install, use, and maintain your laboratory fume hood. Instructions for installing optional equipment on your hood are also included.

Chapter 1: Introduction provides a brief overview of the laboratory fume hood, explains the organization of the manual, and defines the typographical conventions used in the manual.

Chapter 2: Prerequisites explains what you need to do to prepare your site before you install your laboratory fume hood. Electrical and service requirements are discussed.

Chapter 3: Getting Started contains the information you need to properly unpack, inspect, install, and certify your laboratory fume hood.

Chapter 4: Performance Features and Safety Precautions explains how the Protector PVC Hoods operate and the appropriate precautions you should take when using the fume hood.

Chapter 5: Using Your Protector PVC Hood discusses the basic operation of your fume hood.

Chapter 6: Maintaining Your Protector PVC Hood explains how to perform routine maintenance on your fume hood.

Chapter 7: Modifying Your Protector PVC Hood explains how to modify the fume hood or add accessories.

Chapter 8: Troubleshooting contains a table of problems you may encounter while using your laboratory fume hood including the probable causes of the problems and suggested corrective actions.

Appendix A: Protector PVC Hood Components contains labeled diagrams of all of the components of the fume hoods.

Appendix B: Protector PVC Hood Dimensions contains comprehensive diagrams showing all of the dimensions for the laboratory fume hoods.

Appendix C: Protector PVC Hood Specifications contains the electrical requirements for laboratory fume hoods. Wiring diagrams are also included.

Appendix D: References lists the various resources available that deal with laboratory fume hoods.

Typographical Conventions

Recognizing the following typographical conventions will help you understand and use this manual:

- Book, chapter, and section titles are shown in italic type (e.g., *Chapter 3: Getting Started*).
- Steps required to perform a task are presented in a numbered format.
- Comments located in the margins provide suggestions, reminders, and references.
- Critical information is presented in boldface type in paragraphs that are preceded by the exclamation icon. Failure to comply with the information following an exclamation icon may result in injury to the user or permanent damage to fume hood.
- Critical information is presented in boldface type in paragraphs that are preceded by the wrench icon. These operations should only be performed by a trained certifier or contractor. Failure to comply with the information following a wrench icon may result in injury to the user or permanent damage to your hood.
- Important information is presented in capitalized type in paragraphs that are preceded by the pointer icon. It is imperative that the information contained in these paragraphs be thoroughly read and understood by the user.



- A number icon precedes information that is specific to a particular model of laboratory fume hood. The 4' icon indicates the text is specific to the 4-foot wide model. The 5' icon indicates the text is specific to the 5-foot model, etc.
- The P icon indicates the text is specific to the PVC Perchloric Acid model.
- The A icon indicates the text is specific to the PVC Acid Digestion (Lexan Sash) Model.

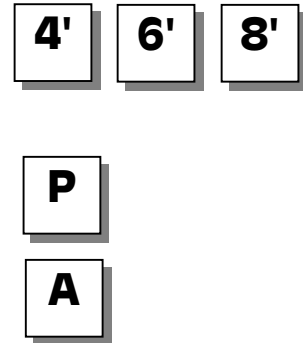

Your Next Step

If your Fume Hood needs to be installed, proceed to *Chapter 2: Prerequisites* to ensure your installation site meets all of the requirements. Then, go to *Chapter 3: Getting Started* for instructions on how to install your laboratory fume hood and make all of the necessary connections.

If you would like to review how laboratory fume hoods operate, go to *Chapter 4: Performance Features and Safety Precautions*.

For information on the operational characteristics of your laboratory fume hood, go to *Chapter 5: Using Your Protector PVC Hood*.

If your laboratory fume hood is installed and you need to perform routine maintenance on the cabinet, proceed to *Chapter 6: Maintaining Your Protector PVC Hood*.

For information on making modifications to the configuration of your fume hood, go to *Chapter 7: Modifying Your Laboratory Fume Hood*.

Refer to *Chapter 8: Troubleshooting* if you are experiencing problems with your fume hood.

CHAPTER 2

PREREQUISITES

Before you install your laboratory fume hood, you need to prepare your site for installation. Carefully examine the location where you intend to install your hood. You must be certain that the area is level and of solid construction. In addition, a dedicated source of electrical power must be located near the installation location.

Carefully read this chapter to learn the requirements for your installation:

- The location requirements.
- The support requirements.
- The exhaust requirements.
- The exhaust washdown requirements.
- The electrical power requirements.
- The service line requirements.
- The space requirements.

Refer to *Appendix B: Protector PVC Hood Dimensions* for complete fume hood dimensions.

Refer to *Appendix C: Protector PVC Hood Specifications* for complete laboratory fume hood electrical and environmental conditions, specifications and requirements.

Location Requirements



The fume hood should be located away from traffic patterns, doors, windows, fans, ventilation registers, and any other air-handling device that could disrupt its airflow patterns. All windows in the room should be closed.

Support Requirements



DO NOT install the fume hood on a cart, dolly, or mobile bench. ALL Protector PVC Hood installations must be permanent and stationary. The supporting structure usually consists of a base cabinet and hardboard support.

Exhaust Requirements

The exhaust duct connection has been designed for 12" nominal duct (12.75" OD) to allow for minimum static pressure loss while operating at 100 fpm face velocities. The 12" diameter exhaust duct also allows for proper transport velocities away from the hood in the 1000 fpm to 2500 fpm range. The exhaust duct used in conjunction with the Protector PVC Fume Hood should be fabricated out of Type I, unplasticized PVC or Type 316 stainless steel. Stainless steel ducting must be fully welded in place so that it does not allow any cracks or holes at the joints to allow for the collection of Perchloric acid salts or acids. The proper exhaust volume and static pressure loss are listed next for each hood model.

NOTE: This chart applies to both the PVC Perchloric Acid Hoods and the PVC Acid Digestion Hoods.

		Full Open 28" Sash Opening		
Hood Size	Standard Model Description	Face Velocity	Exhaust Volume	Static Pressure Loss
4'	48" Protector PVC Hood	80 fpm	590 CFM	0.11" H ₂ O
		100 fpm	730 CFM	0.17" H ₂ O
6'	72" Protector PVC Hood	80 fpm	940 CFM	0.20" H ₂ O
		100 fpm	1180 CFM	0.31" H ₂ O
8'	96" Protector PVC Hood	80 fpm	1330 CFM	0.15" H ₂ O
		100 fpm	1660 CFM	0.22" H ₂ O
		60% Open 18" Sash Opening (sash stop required)		
Hood Size	Standard Model Description	Face Velocity	Exhaust Volume	Static Pressure Loss
4'	48" Protector PVC Hood	80 fpm	380 CFM	0.05" H ₂ O
		100 fpm	470 CFM	0.07" H ₂ O
6'	72" Protector PVC Hood	80 fpm	600 CFM	0.09" H ₂ O
		100 fpm	750 CFM	0.14" H ₂ O
8'	96" Protector PVC Hood	80 fpm	850 CFM	0.06" H ₂ O
		100 fpm	1060 CFM	0.08" H ₂ O

Proper blower selection can be determined from these exhaust requirements and the total system static pressure loss. Contact Labconco Customer Service for assistance in sizing a remote blower system.

Exhaust Washdown Requirements

The entire exhaust duct system must feature an adequate washdown system. This includes the exhaust ductwork, blower, hood structure itself, and any ductwork located outside the blower. Wash rings are required to be placed in the exhaust duct system every 8 to 10 feet and after any change in direction to provide adequate washdown. Contact Labconco for washdown ring ordering information. A washdown and drain should be provided in your exhaust blower. This washdown water and effluent material can be drained from the exhaust blower back into the exhaust duct for disposal. The Protector PVC Hood washdown drain outlet is sized for 2" nominal (2.375" OD) PVC pipe.

Electrical Requirements

The Protector PVC Hood models feature internal wiring for the fluorescent light assembly and light switch. All internal wiring is terminated at the single point wiring junction box for connection by a qualified electrician. The blower switch, and light switch wires are also terminated at the single point wiring junction box for hook-up by a qualified electrician. Refer to *Chapter 3: Getting Started* and *Appendix C: Protector PVC Hood Specifications* for the wiring diagram for proper electrical installation.

Service Line Requirements

All service lines to the laboratory fume hood should be ¼ inch outside diameter, copper (brass for natural gas), and equipped with an easily accessible shut-off valve, should disconnection be required. If the service line pressure exceeds 40 PSI, it must be equipped with a pressure regulator to reduce the line pressure.

Space Requirements

The dimensions for the different models are shown in *Appendix B: Protector PVC Hood Dimensions*.

Your Next Step

After you have determined that the location you have selected accommodates the installation and operational requirements of your fume hood, you are ready to begin installation. Proceed to *Chapter 3: Getting Started*.

CHAPTER 3

GETTING STARTED

Now that the site for your laboratory fume hood is properly prepared, you are ready to unpack, inspect, install, and certify your hood. Read this chapter to learn how to:

- Unpack and move your Protector PVC Hood.
- Set up the fume hood with the supporting structure and work surface.
- Connect to an exhaust system suitable for Perchloric acid and acids.
- Connect the exhaust washdown to the exhaust system.
- Connect to the washdown drain.
- Connect the electrical supply source.
- Connect the service lines.
- Seal the Protector PVC Hood to the hardboard work surface.
- Arrange certification of your Protector PVC Hood.

Depending upon which model you are installing, you may need common plumbing and electrical installation tools in addition to 5/16", 3/8", 7/16", and 1/2" wrenches, ratchets, sockets, a nut driver set, a flat-blade screwdriver, a Phillips screwdriver, and a carpenter level to complete the instructions in the chapter.



The Protector PVC Hood models weigh between 375 to 600 lbs. (170-272 kg). The shipping skid

allows for lifting with a mechanical lift truck or floor jack. If you must lift the fume hood manually, follow safe-lifting guidelines. Normally, the fume hood can be slid off a hydraulic lift table and be placed into position on top of the hardboard work surface. Do not lift by the front air foil. Care must be taken not to damage the drain trough located in the rear of the PVC Fume Hood.

Unpacking Your Laboratory Fume Hood

The United States Interstate Commerce Commission rules require that claims be filed with the delivery carrier within fifteen (15) days of delivery.

Carefully remove the crate and shrink-wrap on your fume hood and inspect it for damage that may have occurred in transit. If your unit is damaged, notify the delivery carrier immediately and retain the entire shipment intact for inspection by the carrier.



DO NOT RETURN GOODS WITHOUT THE PRIOR AUTHORIZATION OF LABCONCO. UNAUTHORIZED RETURNS WILL NOT BE ACCEPTED.



IF YOUR HOOD WAS DAMAGED IN TRANSIT, YOU MUST FILE A CLAIM DIRECTLY WITH THE FREIGHT CARRIER. LABCONCO CORPORATION AND ITS DEALERS ARE NOT RESPONSIBLE FOR SHIPPING DAMAGES.

Do not discard the shipping skid or packing material for your fume hood until you have checked all of the components and installed and tested the unit.

Do not remove the fume hood from its shipping skid until it is ready to be placed into its final location. Move the unit by placing a flat, low dolly under the shipping skid, or by using a floor jack.



Do not move the hood by tilting it onto a hand truck.

Removing the Shipping Skid



LEAVE THE FUME HOOD ATTACHED TO ITS SHIPPING SKID UNTIL IT IS AS CLOSE TO ITS FINAL LOCATION AS POSSIBLE. MOVE THE HOOD BY USING A SUITABLE FLOOR JACK, OR BY PLACING A FURNITURE DOLLY UNDERNEATH THE SKID. DO NOT MOVE THE HOOD BY TILTING IT ONTO A HAND TRUCK.

After you verify the fume hood components, move your hood to the location where you want to install it. Then, follow the steps listed next to remove the shipping skid from your hood.

1. Remove the side panels by unscrewing the Phillips screws.
2. Find the hardware (bolts, washers, nuts) that attach the fume hood to the skid and remove the hardware. Some hardware is on the sides and some is on the back.

Sash Weight Release

To protect the fume hood from damage in shipment, the sash weight has been secured to the back of the fume hood with four (4) screws. Remove the screws and make sure the sash cables are on the pulleys before operating the sash. On models with more than one sash, the sash weights have been secured to the shipping skid with lag screws. Remove the weights from the skid and attach them to the respective sash cables using the hooks provided.



NOTE: THE SASH WEIGHT WAS SIZED FOR THIS SPECIFIC HOOD AND SHOULD NOT BE EXCHANGED ON ANY OTHER HOOD.

Install the Protector PVC Hood on a Supporting Structure and Hardboard Support



The Protector PVC Hood is heavy! Use caution when lifting or moving the hood.

When installing the Protector PVC Fume Hood onto the hardboard work surface or benchtop, ensure that the structure can safely support the combined weight of the fume hood and any related equipment. The hardboard support surface should be at least as wide as the hood to properly support it. **The hardboard surface is mounted flush with the back of the fume hood; this will provide the correct spacing under the air foil for proper bypass airflow. The hardboard support surface has a cutout to avoid the drain trough.**



WARNING: It is important to support 1) the rear of the hood with a cross support for the bottom of the hardboard surface. 2) Install the cross supports after the base cabinets and hardboard support are leveled.

The following are instructions for mounting a cross support, and installing the hardboard support:

1. Level the base cabinets and the hardboard surface. The hardboard surface should be placed flush with the back of the fume hood as shown in Figure 3-2. The hardboard surface has a cutout to allow for clearance around the rear washdown drain trough.
2. Scribe a line on the wall or back of the base cabinet to locate the cross support under the hardboard surface.
3. Mount the cross support by attaching it to the wall or base cabinet.

4. Anchor cabinet(s) with seismic restraints if required by the local code in your area.

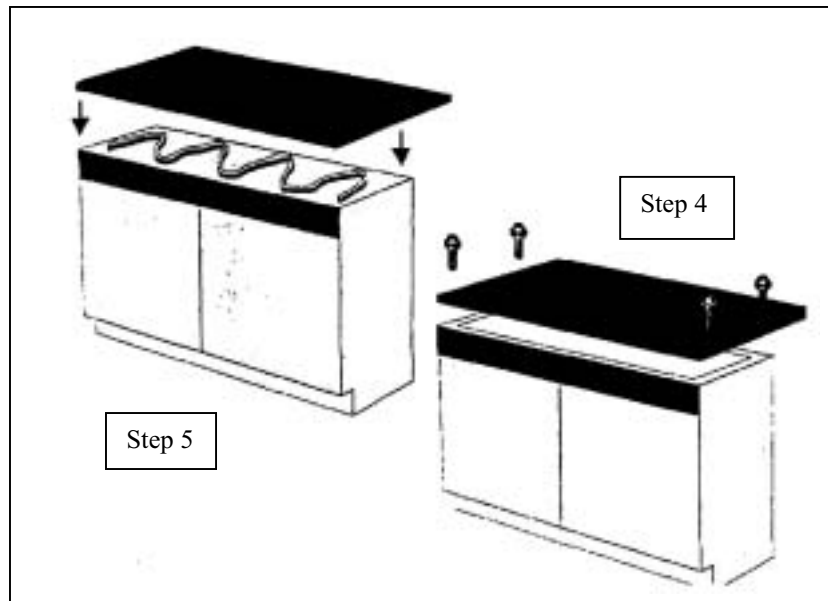

Figure 3-1

5. Secure the hardboard surface to the top of the base cabinet(s) using adhesives with the Solvent Storage Cabinets(s) or mechanical fasteners with the Acid Storage Cabinet(s). Be sure the PVC Hood drain trough is accounted for in the relief area of the hardboard top. See figure 3-2.
6. After completing step 5, apply a sufficient quantity of adhesive to the top surface of the hardboard.
7. Place the hood on top of the work surface and cross support.
8. Place heavy weights on the inside of the fume hood for approximately 24 hours. This provides a proper bond of the adhesive. Protect the hood's integral work surface from possible damage by wrapping any weighted material first.

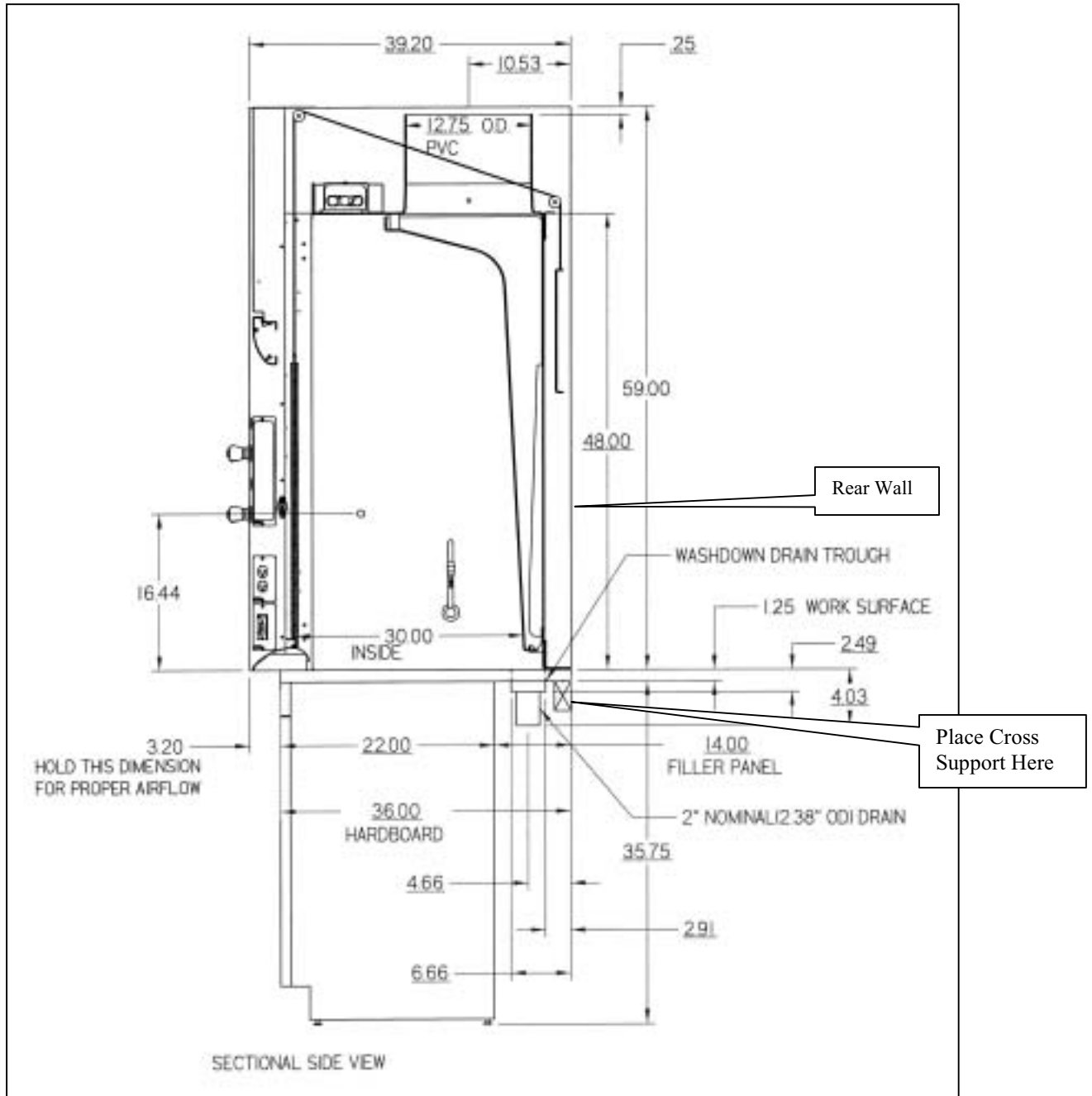

Figure 3-2

Connecting to the Protector PVC Hood Exhaust System



WARNING: The weight of the stainless steel or PVC exhaust ductwork system must be supported independently of the hood superstructure. Do not allow this weight to be supported by the hood structure as damage to the hood may occur.



The stainless steel or PVC exhaust connection should be installed by a qualified HVAC contractor.

The exhaust connection on your hood has been designed for 12" nominal pipe (12.75" OD) to allow for minimum static pressure loss with proper transport velocities away from the hood. Consult Labconco Customer Service should you require help sizing your blower for the exhaust volume and total system static pressure loss.



The selected exhaust duct material must be fabricated out of type 1 unplasticized polyvinyl chloride or type 316 stainless steel material. The duct should be fully welded in the case of the stainless steel material or solvent bonded in the case of polyvinyl chloride so that it does not have any cracks or holes where Perchloric acid salts or acids can collect.

The exhaust duct system for a PVC Fume Hood should be run in a vertical position and feature horizontal runs only where it cannot be avoided. Should a horizontal run be a part of your exhaust system, it should be sloped downward toward the hood to

prevent the pooling of the washdown water and perchloric acid salts or acids in the duct.



CAUTION: PVC Fume Hoods must never be manifolded into a common exhaust system. They require a dedicated exhaust system.

Connecting to the Exhaust Washdown

The entire exhaust duct system must have an adequate washdown system. This includes the exhaust ductwork located between the exhaust blower and the hood structure, the exhaust blower, and any ductwork located on the outlet side of the blower. Wash rings are recommended to be placed in the exhaust duct system approximately every 8 to 10 feet and after every change in direction to provide an adequate washdown. A drain should be provided in your exhaust blower and this washdown water and effluent material can be drained from the exhaust blower back directly into the exhaust duct for disposal. The PVC Hood was designed with an auxiliary port plugged at the factory, and it is to be connected to the washdown valve system to provide water to the wash rings. The plug is located on top of the hood near the first washdown nozzle. Plumb from the plugged connector with a 3/8" rigid polyethylene, copper, or stainless steel line.

Connecting to the Washdown Drain

The Protector PVC Hood has been supplied with a 2" nominal (2.375" OD) PVC pipe drain. Connect the 2" pipe to your floor drain. Be sure the connection is either fully solvent bonded or leak tight. See Figure 3-2.

Connecting the Electrical Supply Source to the Protector PVC Fume Hood

Prior to connecting any electrical wiring to the fume hood structure, refer to the hood identification plate for the proper electrical requirements of your specific model.



WARNING: The building electrical supply system for Protector PVC Hoods should include overload protection. A switch or circuit breaker should be in close proximity to the equipment and within easy reach of the operator. The switch or circuit breaker is to be marked as the disconnecting device for the equipment. Consult the 2002 edition of the National Electrical Code for proper installation.

The identification plate, model number, serial number, and electrical connection boxes are accessible from the front of the fume hood by removing the front panel. See Figure 3-3.

The Protector PVC Hood is normally wired for 115 Volt, 60 Hz, 20 Amp or 230 Volt, 50 Hz, 10 Amp electrical services. The number of circuits varies depending on the model. All of the electrical connections are terminated at the single point internal junction box for hook-up by a qualified electrician. The single point internal junction box is used for the connection of the lights, blower, and duplex outlets. Refer to the wiring diagram for your Protector PVC Hood in *Appendix C: Protector PVC Fume Hood Specifications*.

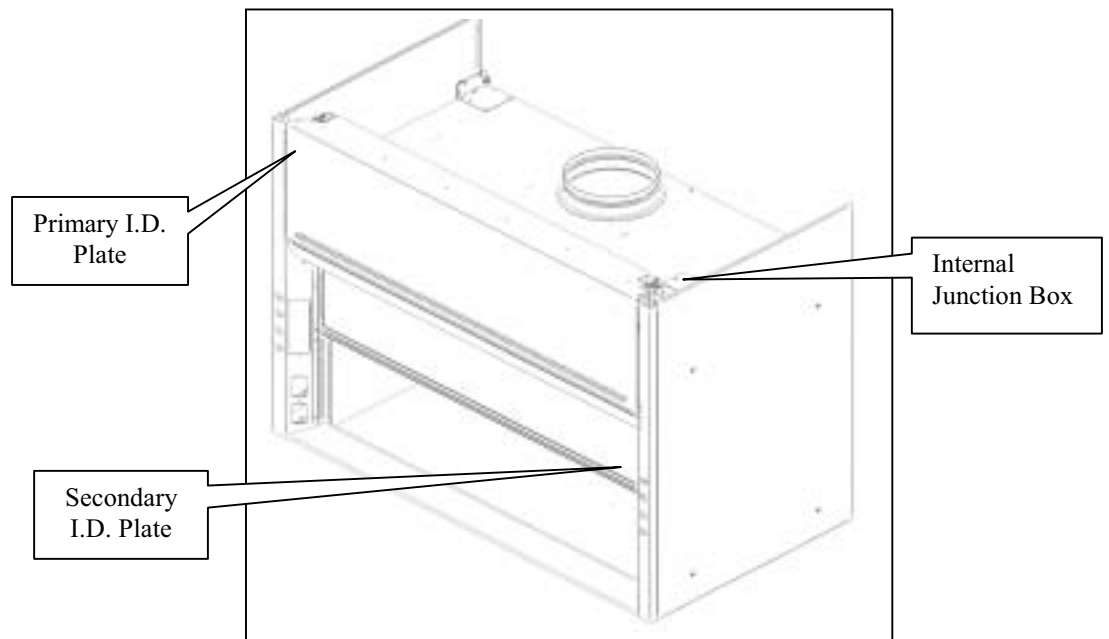

Figure 3-3



All wiring for the fume hood SHOULD be performed by a licensed electrician, and conform to all local codes. In most cases, the hood will require the use of shielded conduit to protect the wiring into the hood. The grounding connection shall not be made to the terminal box cover.

The fluorescent light has been mounted outside the top liner panel and is sealed from vapors inside the hood structure. To change the fluorescent light bulbs in your hood, you must first remove the front panel from the hood. Next remove the screws holding down the light reflector(s). Remove the light reflector(s) and slide out of the way temporarily.

The fluorescent lights are now fully exposed and ready for service. While the fixture is in this position, replace the defective bulbs, and reassemble.

Connecting the Service Lines to the Protector PVC Fume Hood

The hoods with service fixtures have been plumbed from the valve to the hose connector or gooseneck for your installation convenience. Supply tubing shall be provided by the qualified installer. Tubing can enter the hood from above, through the back, or through the work surface to make these connections to the service fixtures.



NOTE: Inspect all fittings for leakage. Tighten the fittings slightly if needed.



CAUTION: Do not use oxygen with any standard service fixture. Contact Labconco Customer Service for oxygen fixture information.

Should access to the hood plumbing fixture bodies be required, remove the service access plate on the hood front corner posts by loosening their individual screws. (See item 11 Figure A-1, page 59) The valve body will now be fully exposed for any service work that may be necessary. The service fixtures supplied on your laboratory hood are designed for use with the following services:

- Air
- Cold Water
- Hot Water
- Natural Gas – See Caution Below
- Vacuum



WARNING: Contact Labconco Customer Service directly before using any service other than those listed above in these valves to assure full compatibility.



CAUTION: Natural gas should be used only in the service fixture that has been pre-plumbed with brass tubing. Sulfur content of the gas could cause deterioration of standard copper supply lines.

Connecting the Washdown Control Fixture to the Protector PVC Fume Hood

The control valve used for the washdown system is located on the left hand side of the hood superstructure, upper fixture position. The valve assembly has been fully plumbed to the internal spray nozzles and a connection point has been left for the addition of the water line used on exterior mounted wash rings. This connection is located in the upper left hand portion of the fume hood structure near the first washdown nozzle. The supply line for the washdown control valve, features 3/8" diameter copper tubing. A qualified installer shall provide the supply line tubing.

Certifying the Protector PVC Fume Hood

The combination of your laboratory hood, exhaust ductwork, and exhaust blower gives you the flexibility to change the airflow at the sash opening of your hood. To determine the actual face velocity at the sash opening, airflow velocity readings will need to be taken. This should be done across the sash opening of the hood in accordance with the *Industrial Ventilation Manual* section on laboratory hoods. (See *Appendix D – Reference*) Labconco recommends an average face velocity at the sash opening of 80 to 100 feet per minute.

Your Protector PVC Fume Hood has been tested at the factory per ASHRAE 110-1995. All hoods achieve an “as manufactured rating” of less than 0.10 part per million (ppm) at 4 liters per minute (lpm), (AM <0.10). (Consult Labconco for individual fume hood rating.) For “field use” ASHRAE testing, contact Labconco Ventilation Ventures Team or Customer Service for a certified on-site contractor.



NOTE: Face velocity profiles and smoke testing should be done periodically to ensure safe performance.

Your Next Step

After your fume hood has been installed and certified, you are ready to proceed to *Chapter 4: Performance Features and Safety Precautions*.

CHAPTER 4

PERFORMANCE

FEATURES AND

SAFETY

PRECAUTIONS

Performance Features:

Your Protector PVC Perchloric Acid Fume Hood has been engineered to efficiently ventilate and remove Perchloric acid fumes. The Protector PVC Acid Digestion Fume Hood has been engineered to efficiently ventilate and remove acid fumes of all kinds (excluding Perchloric acid) including hydrofluoric acid (HF). The Protector PVC Acid Digestion Hood must not be used with Perchloric acid as it can react with the Lexan sash. The Protector PVC Fume Hoods are designed to provide a flow of air sufficient to extract the acid fumes from within the work area and keep them away from the operator to avoid ingestion, inhalation, or skin contact.

The hood interior is constructed of seamless PVC with coved interior corners. The hood also features an integral washdown system, which helps prevent the accumulation of perchlorates or acids. The smooth interior finish compliments the washdown

system as there are no screws or hollow fasteners present that could harbor undesirable residue.

The Protector PVC Fume Hood has been engineered to allow you, the customer, the maximum work area and personnel safety. The bypass air configuration on the Protector PVC Fume Hoods is totally dependent on air being supplied to the hood from its surrounding environment for proper operation.

As stated previously, the Protector PVC Perchloric Acid Hood is designed to handle Perchloric acid operations of all types, while the PVC Acid Digestion Hood is designed to handle acids of all kinds (excluding Perchloric acid) including hydrofluoric acid (HF). Usage of materials other than the specific acids mentioned above is not recommended. Perchloric acid is a strong oxidizing agent, and should not be used in combination with any organic material as the possibility of a hazardous chemical reaction or explosion could develop.

The integral washdown system in either PVC Fume Hood allows the operator the ability to wash behind the baffle and ensure that a build-up of Perchloric salts or other acids does not develop in that location. All of the washdown water from the internal spray nozzles is contained behind the baffle and does not interfere with normal operations being performed inside the hood. The washdown water is collected in the hood drain trough.

The hood liner must be washed down manually by the operator. The internal washdown system can be connected to the wash rings used in your hood exhaust system. The water used in the spray wash rings is collected in the hood drain trough once it has been allowed to flow down and cleanse the duct thoroughly.



WARNING: It is recommended that the PVC Hood be washed down thoroughly after every usage for 10 minutes, at least once a day.

1. **Unique sash provides maximum visibility of 32.15" high while conserving energy by limiting sash travel to 28"**. Vertical-rising sash may be raised from a closed to 28" operating height. Exhaust volume and blower sizing are based on the 28" height. Optional sash stops are available to limit sash height and reduce energy usage. The PVC Perchloric Acid Hood has a glass sash specifically used for Perchloric Acid. The PVC Acid Digestion Hood has a Lexan sash specifically used for all acids (excluding Perchloric acid) including hydrofluoric acid (HF). **NOTE:** Hydrofluoric acid will etch or fog standard plate glass, but not Lexan plastic.
2. **By-pass airflow design** ensures relatively stable face velocities.
3. **Large usable interior work depth and interior height of 48"** provides ample working space.
4. **Baffle** directs airflow to the rear of the interior to provide efficient airflow. The baffle may be removed for cleaning purposes only.
5. **Exterior access cover plates** are removable for easy access to plumbing valves when access through the sides is not available.
6. **Lift-Away™ front panel** provides easy access to electrical wiring, sash weights, and lighting fixtures.
7. **Energy efficient fluorescent lighting** is located behind a laminated safety glass shield mounted to the top of the hood. The factory-wired lighting is serviceable from outside the hood cavity.
8. **Low-mounted, factory-wired light and blower switches** are ADA compliant.
9. **Clean-Sweep™** air foil allows air to sweep the work surface for maximum containment.
10. **Streamlined corner posts** provide maximum visibility and the flexibility to add services;

services are most easily added at the factory, because of the PVC liner.

11. **All hoods are factory-prepared for up to 7 service fixtures.** Additional fixtures are available only as a factory special. Liner hole drilling is required to add another fixture in the field.
12. **One duplex electrical receptacle** is mounted on the right corner post. Receptacles are factory-wired to hood single point junction box. Additional electrical receptacles are available as factory or field installed.
13. **PVC interior liner** is seamless PVC with coved interior corners and integral work surface.
14. **Accessory Guardian™ Digital Airflow Monitor** or **Guardian Jr. Monitor** continuously monitors face velocity. An audio/visual alarm alerts the user to low airflow conditions. The right corner post is factory prepared to accommodate the Guardian Monitor (sold separately).
15. **Optional Energy-Reducing A-Style Combination Sash Models.** These combination sashes allow the operator to use the hood with sashes either half open vertically or horizontally to conserve energy. Optional sash stops prevent raising the vertical sash above the half-open and fully closed positions unless manually defeated by the operator.
16. **Outside frame of epoxy-coated steel and galvanized steel** is durable and corrosion resistant.
17. **Exhaust connection.** The hood features 12" (12.75" OD pipe) PVC exhaust connections sized to allow for a minimum static pressure loss through the hood structure while providing a good transport velocity through the exhaust system.
18. **Solid hardboard support** provided to support the integral PVC bottom.

19. **Optional Ceiling Enclosure Kits** are available for a decorative facade between the hood and the ceiling.
20. **Optional Sash Stops** provide a means of controlling the operating height of the sash.
21. **Washdown control fixture.** Located on the left hand side of the hood superstructure, this valve controls the water flow to the integral washdown spray nozzles. The nozzles are located behind the hood baffle and washdown areas in the hood, which are inaccessible without removing the baffle. The control fixture can also be set up to control the washdown system used in your exhaust ductwork. To do this, connect the water line from your external washdown system to the plugged connection provided on the top of the internal washdown assembly.

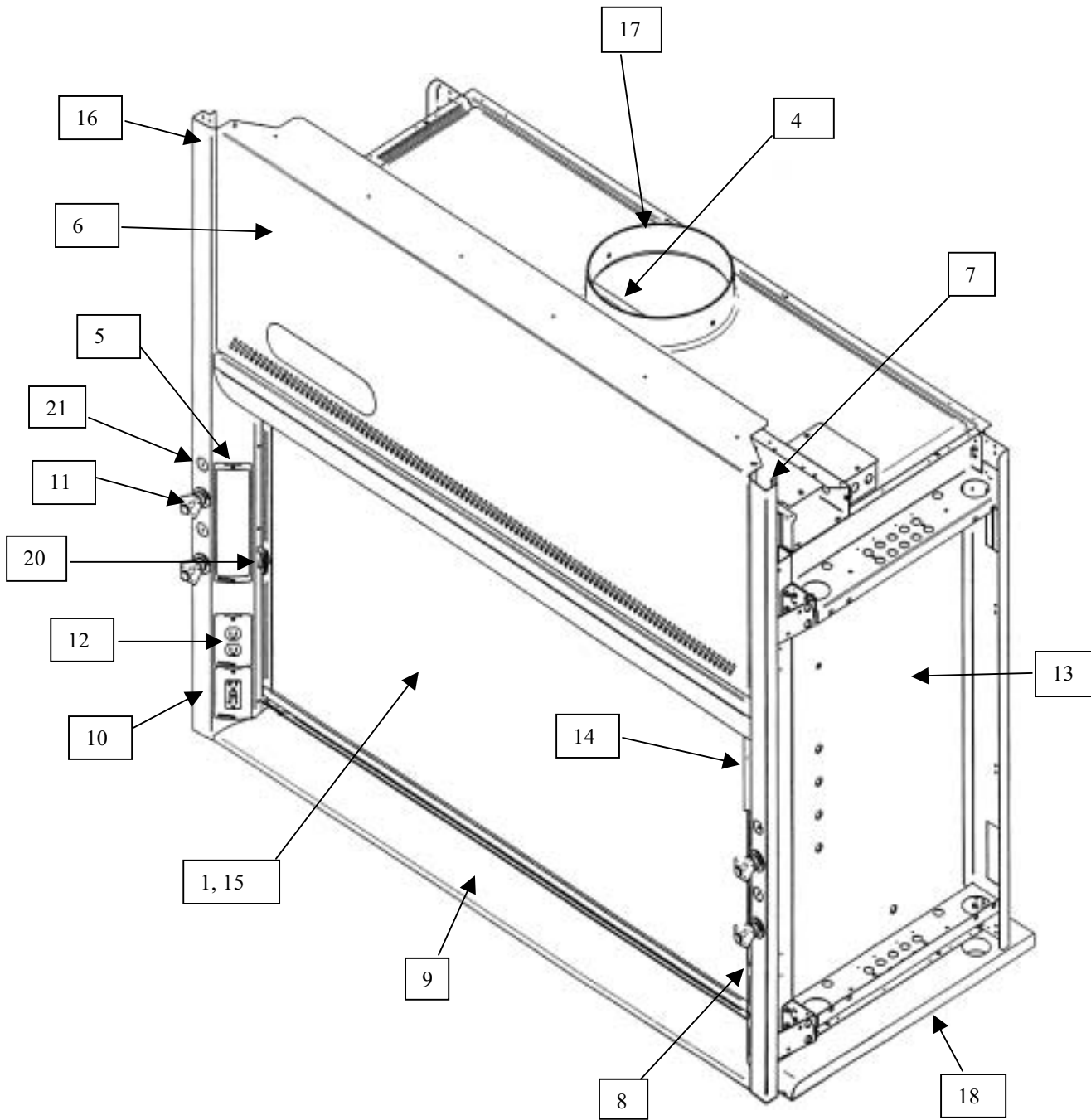

Safety Precautions



Although the laboratory hood has been engineered to maintain optimum operator safety, caution should always be used while working in the hood. Prior to using the hood, check to make sure that the exhaust blower is operating and that air is entering the hood at its specified face velocity.

Do not place any hot items directly on the PVC Hood integral work surface.

Always keep the ventilation system in operation when using any heat generating source inside the PVC Hood. Severe damage to the PVC Hood liner and PVC baffle can occur if the ventilation system is turned off before the heat load inside has been reduced to a safe level.



USE GOOD HOUSEKEEPING IN THE HOOD AT ALL TIMES.

CLEAN UP SPILLS IMMEDIATELY WITH A MILD DETERGENT. PERIODICALLY CLEAN HOOD INTERIOR, INCLUDING FLUORESCENT LIGHT GLASS PANEL. REPLACE BURNED OUT LIGHT BULBS TO MAINTAIN MAXIMUM ILLUMINATION.

DO NOT OVERLOAD THE WORK SURFACE WITH APPARATUS OR WORK MATERIAL. THE SAFE OPERATION OF THE LABORATORY HOOD IS BASED UPON HAVING PROPER

AIRFLOW THROUGH THE STRUCTURE. DO NOT PLACE LARGE, BULKY OBJECTS SUCH AS BLOCK HEATERS, DIRECTLY ON THE HOOD WORK SURFACE. INSTEAD, ELEVATE THE OBJECT 2" TO 3" ON BLOCKS TO ALLOW A FLOW OF AIR UNDER THE OBJECT AND INTO THE LOWER REAR BAFFLE EXHAUST SLOT. ENSURE BLOCKS ARE LEVEL AND SECURED IN PLACE.



Blocking the bottom of the baffle at the rear of hood will change the airflow pattern in the hood causing turbulence and possible leakage at the face of the hood. (Don't store containers or supplies against baffles, as this will affect airflow through the hood).

Avoid placing your head inside hood. Keep hands out of hood as much as possible.

Always work as far back in hood as possible. It is best to keep all chemicals and apparatus 6" inside the front of the hood.

Perchloric acid use in PVC Perchloric Acid Hoods is recommended. Perchloric acid is not allowed in PVC Acid Digestion Hoods.

Wash the hood down thoroughly after each usage or at least once a day for a period of 10 minutes.



Safety requires regular washdown of fume hood interior, ductwork, and the movement of air preferably after each experiment. The baffle on this hood may be removed for access to all surfaces as a follow-up to washdown procedures. All deposits should be flushed away. Utilize lowest quantities of Perchloric acid or acids to fit procedural requirements.

The use of Perchloric acid creates extreme inherent hazard because of its certain characteristics. Since there is a constant danger of explosion when using Perchloric acid, it is recommended that laboratories employing its use in any quantity become well informed of its characteristics. Only personnel fully cognizant with the properties of Perchloric acid and the hazards associated with it should perform Perchloric acid procedures.

The PVC Perchloric Acid Hood is specially designed for use with Perchloric acid. It should not be used as a general-purpose laboratory fume hood. Do not work with organic materials in the PVC Perchloric Acid Fume Hood. Perchloric acid when used with organic material can cause a hazardous chemical reaction or explosion. Because of extreme hazards, miscellaneous work should not be performed in this hood. Do not store chemicals in a fume hood.

All apparatus used within the hood interior should have inorganic coatings and lubricants.

Although, the Protector PVC Perchloric Acid Fume Hoods conform to all generally accepted standards of design for this type of equipment, we accept no responsibility or liability for accidents that may possibly occur in the use of Perchloric acid in our hoods.

Radioisotope materials are not recommended for use in PVC Hoods.



AVOID CROSS DRAFTS AND LIMIT TRAFFIC IN FRONT OF THE HOOD. AIR DISTURBANCES CREATED MAY DRAW FUMES OUT OF THE HOOD.



The use of heat-generating equipment in this hood without the exhaust system operating properly can cause damage to the hood.

The Protector PVC Laboratory Hoods should be certified by a qualified certification technician before initially used. The hood should be re-certified whenever it is relocated, serviced or at least annually thereafter.

Ensure that the hood is connected to electrical service in accordance with local and national electrical codes. Failure to do so may create a fire or electrical hazard. Do not remove or service any electrical components without first disconnecting the hood from electrical service. Proper operation of the fume hood depends largely upon the hood's location and the operator's work habits. Consult the *Reference Manual in Appendix D*.

Your Next Step

After you understand the theory of operation and safety precautions, you are ready to proceed to *Chapter 5: Using Your Protector PVC Fume Hood*.

CHAPTER 5

USING YOUR PROTECTOR PVC FUME HOOD

Operating the Vertical- Rising Glass Sash



Because of the Protector PVC Perchloric Acid Hood's counterbalanced sash mechanism, it will take only a few pounds of force to move the sash up or down, and you can operate the sash smoothly with one or two hands positioned any where along the handle. The glass sash is suitable for use with Perchloric acid. The vertical-rising sash may be raised to a maximum 28" operating height. The airflow requirements should be sized for the 28" operating height; if using sash stops then the airflow requirements can be reduced by approximately 40% at 18" or approximately 50% at 15".

A

Operating the Vertical-Rising Lexan Sash

Because of the Protector PVC Acid Digestion Hood counterbalanced sash mechanism, it will take only a few pounds of force to move the sash up or down, and you can operate the sash smoothly with one or two hands positioned any where along the handle. The Lexan sash prevents fogging caused by hydrofluoric acid (HF). The Lexan sash is suitable for acids other than Perchloric acid, which can react with the Lexan plastic. The airflow requirements should be sized for the 28" operating height, if using sash stops then the airflow requirements can be reduced by approximately 40% at 18" or approximately 50% at 15".

P

A

Operating the Blower

Your Protector PVC Fume Hood utilizes a remote style blower, which can be activated by turning the blower switch to "ON." You can validate the hood performance by watching smoke drawn into the hood face opening.

P

A

Operating the Lights

Your Protector PVC Fume Hood utilizes a factory-wired fluorescent light to illuminate the hood interior. Simply turn the light switch to "ON" to operate.

P

A

Operating the Washdown Control Valve

Your Protector PVC Fume Hood has a washdown control valve located on the upper left-hand side that controls water to the washdown spray nozzles. The nozzles are located behind the hood baffle and will washdown areas in the hood, which are inaccessible without removing the baffle. The washdown control system can also be set up to control the washdown rings used in your exhaust ductwork. This is done by

connecting the water line to the plugged connection on top of the washdown hood system.

Working in your Protector PVC Fume Hood

Planning

- Thoroughly understand procedures and equipment required before beginning work.
- Arrange for minimal disruptions, such as room traffic or entry into the room while the hood is in use.

Start-up

- Turn on fluorescent light and hood blower.
- Slowly raise the sash.
- Check the baffle air slots for obstructions.
- Allow the hood to operate unobstructed for 5 minutes.
- Wear a long sleeved lab coat and rubber gloves. Use protective eyewear. Wear a protective mask if appropriate.

Loading Materials and Equipment

- Only load the PVC Hood materials required for the procedure. Do not overload the hood. Only use Perchloric acid in the PVC Perchloric Acid Fume Hood.
- Radioisotope materials are not recommended for use in these PVC Hoods. Consult your Safety Officer should you have any questions.
- Do not obstruct the front air foil, or rear baffle slots.
- Large objects should not be placed close together and spaced above the liner bottom to permit airflow to sweep under the equipment.
- After loading the hood, wait one minute to purge airborne contaminants from the work area.

Work Techniques

- Keep all materials at least 6 inches inside of the sash, and perform all contaminated operations as far to the rear of the work area as possible. Segregate all clean and contaminated materials in the work area.

- Avoid using techniques or procedures that disrupt the airflow patterns of the hood.

Final Purging

- Upon completion of work, the hood should be allowed to operate for two to three minutes undisturbed, to purge airborne contaminants from the work area before shutting down blower.

Unloading Materials and Equipment

- Objects in contact with contaminated material should be surface decontaminated before removal from the hood.
- All open trays or containers should be covered before being removed from the hood.

Final Washdown Procedure

- Water washdown or flooding the surfaces with water is standard practice and results in reduction of contamination on the PVC liner material due to Perchloric acid salts or acids.
- Proper operation of your PVC Fume Hood requires that you wash the fume removal system down sufficiently to ensure that there is no build up of Perchloric acid salts or acids within the entire system.
- Normal washdown procedures suggest that you run the wash system in the exhaust duct with the fan on for approximately 1-2 minutes, and then with the fan off for approximately 10 minutes to thoroughly clean this portion of the exhaust system.
- In addition to this, the internal hood spray nozzles should be activated for approximately 10 minutes after the completion of your procedures to clean behind the baffle in the hood. Work areas in front of the baffle in the hood will need to be manually cleaned by the operator. Because the volume of Perchloric acid salts or acids can vary greatly due to specific procedures and workloads, you should consult your in-house Safety Officer for specific rules and frequency requirements for washing down your total system.

Shutdown

- Only turn off the fluorescent light and hood blower if final washdown is complete, and then close the sash.

Your Next Step

After you understand how to operate and work in the fume hood, you are ready to proceed to *Chapter 6: Maintaining Your Protector PVC Fume Hood*.

CHAPTER 6

MAINTAINING YOUR PROTECTOR PVC FUME HOOD

Now that you have an understanding of how to work in the fume hood, we will review the suggested maintenance schedule and the common service operations necessary to maintain your fume hood for peak performance.



Only trained and experienced certification technicians should perform some of the service operations after the fume hood has been properly decontaminated and washed down. DO NOT attempt to perform these operations if you are not properly trained. The wrench icon precedes the service operations that require qualified technicians.

Routine Maintenance Schedule

Daily

- Washdown PVC liner and PVC baffle surfaces (if used daily) from Perchloric acid salts or acids as outlined in Chapter 5 Final Washdown.

Weekly

- Using ordinary dish soap to clean the surface inside of the fume hood, and the work surface.
- Using an appropriate glass cleaner, clean the sash and all glass surfaces.
- Operate the fume hood blower, noting the airflow velocity through the hood using a source of visible smoke.

Monthly (or more often as required)

- Determine the actual face velocity through the sash opening of the hood where the average reading should be at the specified velocity. (Use calibrated thermal anemometer or other approved apparatus).
- Using a damp cloth, clean the exterior surfaces of the hood, particularly the front of the hood, to remove any accumulated dust.
- Check all service valves, if so equipped, for proper operation.
- The hood baffle should be checked for blockages behind it to ensure that the hood is maintaining proper airflow.
- All weekly activities.

Annually

- Replace the fluorescent lamps.
- Have the fume hood recertified by a qualified certification technician. See *Certifying the Protector PVC Fume Hood* in Chapter 3.
- All monthly activities.

Biannually

- The sash assembly should be checked to ensure proper operation and to make sure there are no



signs of abnormal wear on the sash pulleys, cables and clamps.

Routine Service Operations

Front Panel Removal:

1. Simply lift the front panel up and then away from the hood to provide access to the top.

Changing the Fluorescent Lamp:

1. Turn light switch to “OFF.”
2. Remove the front panel as noted earlier.
3. Reach over the front header of the hood and loosen screws to the light reflector and remove light reflector.
4. Remove the fluorescent lamp by pushing it out of the spring-loaded lamp socket and swinging it out of the other lamp socket.
5. Install the new lamp by reversing the removal procedure.

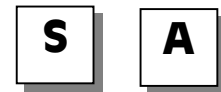

Your Next Step

After you understand the maintenance procedures, you are ready to proceed to *Chapter 7: Modifying Your Protector PVC Fume Hood*.

CHAPTER 7

MODIFYING YOUR PROTECTOR PVC FUME HOOD

There are several ways to modify the fume hood for your individual requirements. These include the addition of work surfaces, service fixtures, air monitor, distillation grids, electrical duplex outlets, ceiling enclosures, and rear panels.

Installing Hardboard Support Surface

Your Protector PVC Fume Hood requires a hardboard support surface to properly support the integral work surface of the one-piece PVC liner. The hardboard support is shipped and included with the PVC Fume Hood. Be sure to secure the hardboard support per the instructions on pages 14 and 15 in Chapter 3.



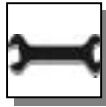

Installing Ceiling Enclosures above the Fume Hood

Your Protector PVC Fume Hood has mounting holes to accept a ceiling enclosure to close off the area between the top of the hood and the ceiling. Contact Labconco Customer Service for ordering information.

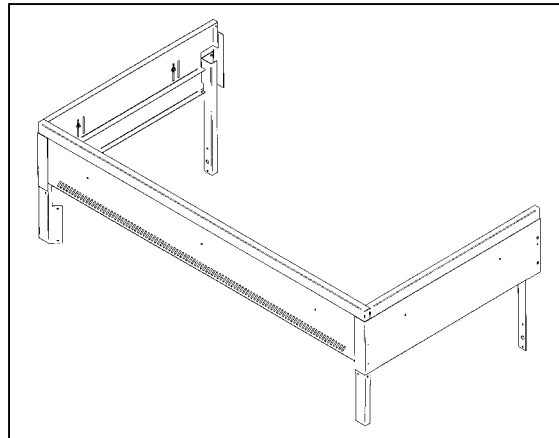

Figure 7-1



Installing Rear Panels Behind the Fume Hood

Your Protector PVC Fume Hood can be modified to add a rear panel behind the fume hood when the fume hood is placed on an island.

Installing Additional Service Fixtures



Additional service fixtures can be installed. The fume hood is factory set to accept up to four valves per side, but the liner is not drilled for extra fixtures. Contact Labconco Customer Service for information.



Figure 7-2 Knob

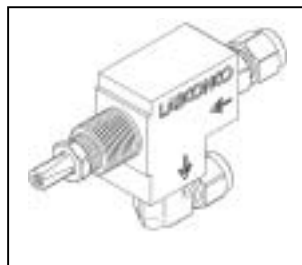

Figure 7-3 Valve

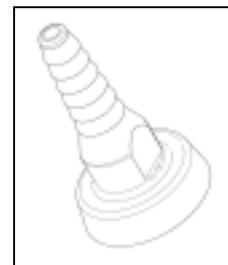

Figure 7-4 Hose Connector

Installing Guardian™ 335 Digital Airflow Monitor or Guardian™ Jr. Airflow Monitor



The Guardian Digital Airflow Monitor P/N 9743201 or Guardian Jr. Airflow Monitor P/N 9743202 allows you to continuously monitor face velocity through the fume hood opening. The fume hood right corner post is factory prepared to mount either monitor. To mount the Guardian Digital Monitor the hood liner needs a 0.50" diameter hole mounted on the right side; 2" above the sash handle at its uppermost height and 6" behind the sash.

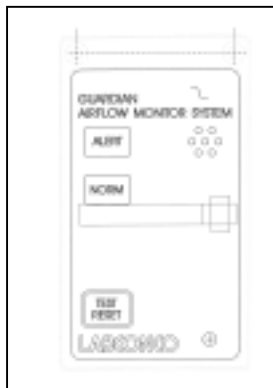

Figure 7-5

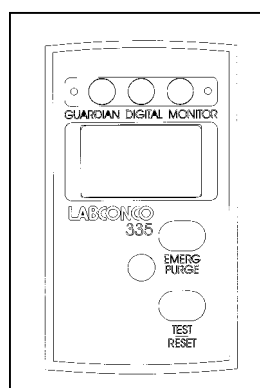
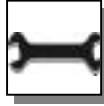

Figure 7-6

Sash Stop Kit – Field Installation



The Sash Stop P/N 9724500 restricts how far a vertical-rising sash may be opened. This small plastic device may be easily field installed on the fixture corner post of any fume hood. The metal bracket is simply mounted to the sash handle.

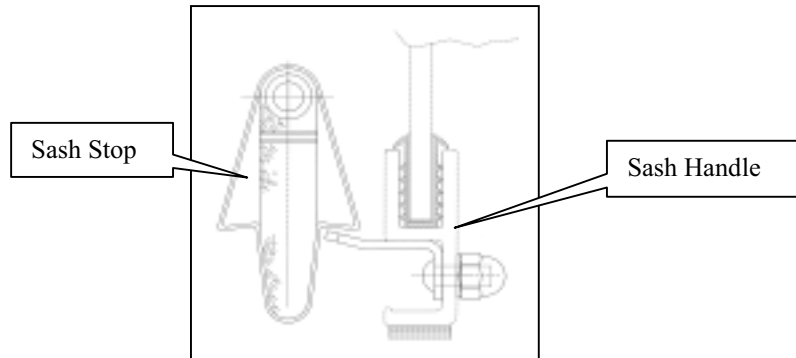

Figure 7-7

Installing an Electrical Duplex Outlet



Your Protector PVC Fume Hood can be ordered with duplex outlets, however, if you ordered a model without an electrical duplex outlet you can have one installed in the field by a qualified electrician. Contact Labconco Customer Service for ordering information. (Not permitted on explosion-proof hoods.)

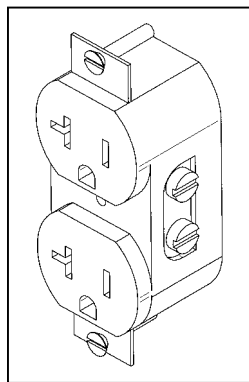

Figure 7-8

Your Next Step

After you understand the modifying procedures, you are ready to proceed to *Chapter 8: Troubleshooting*.

CHAPTER 8

TROUBLESHOOTING

Refer to the following table if your fume hood fails to operate properly. If the suggested corrective actions do not solve your problem, contact Labconco for additional assistance.

PROBLEM	CAUSE	CORRECTIVE ACTION
Remote blower and lights won't operate	Wires not connected at junction boxes or switches.	Check connection of switches. Check connection to control box on top of unit.
	Circuit breakers tripped in building electrical supply.	Reset circuit breakers.
	Remote blower won't operate, but lights work	Blower wiring is disconnected. Belt broken. Blower motor is defective.
Fume hood blower operates but lights will not operate	Lamp not installed correctly.	Inspect lamp installation.
	Lamp is defective.	Replace lamp.
	Lamp circuit breaker in building is tripped.	Reset the lamp circuit breaker.

PROBLEM	CAUSE	CORRECTIVE ACTION
Fume hood blower operates but lights will not operate	Lamp wiring is disconnected.	Inspect lamp wiring.
	Defective lamp ballasts.	Replace lamp ballasts.
Contaminants escape outside of fume hood	Improper user techniques for the fume hood.	See “Certifying the Hood” Chapter 3 and “Safety Precautions” Chapter 4 sections in the manual. (Ref. Appendix D).
	Restriction of the baffle air slots or – blockage of the exhaust outlet.	Remove baffles to ensure that all air slots and the exhaust outlet are unobstructed.
	External factors are disrupting the fume hood airflow patterns or acting as a source of contamination.	See “Location Requirements” Chapter 2, “Certifying the Hood” Chapter 3, and “Safety Precautions” Chapter 4 sections of this manual. (Ref. Appendix D)
	Fume hood has improper face velocity.	Have fume hood re-certified and check remote blower exhaust system. Hood should have average face velocity of 80-100 fpm.
Vertical sash no longer operates smoothly	Cable is frayed or plastic protection is damaged.	Inspect cable and replace cable if worn or damaged immediately; otherwise injury could result.
	Pulley bearing is damaged.	Replace pulley, bearing or add grease.
	Cable has slipped off the pulleys.	Re-install, cable must be replaced immediately if damaged.
	Weight has broken pulleys.	Replace weight pulleys.
Combination A-Style sash no longer operates smoothly	Horizontal-sliding glass panels have come off the tracks.	Re-install horizontal-sliding glass on tracks.

PROBLEM	CAUSE	CORRECTIVE ACTION
	Vertical-rising sash frame is distorted.	Place horizontal sliding glass symmetrically and pull sash down to air foil. Straighten damaged frame.
	Cable is frayed or has slipped off the pulleys.	Re-install, cable must be replaced immediately if damaged.
Electrical duplex outlets no longer have power	Wires not connected or faulty duplex.	Check wire connection or replace duplex.
	Circuit breakers tripped in building electrical supply.	Reset circuit breakers.
Service valves no longer operate	Faulty building supply.	Inspect building supply shut off valves and appropriate pressures below 40 PSI.
	Valve no longer operates.	Replace valve and check for leaks.
	Supply line or outlet line has leaks.	Inspect line for leaks and fix any leaking plumbing connections.
Spray Nozzles no longer work	Poor water supply	Inspect building water supply.
	Clogged nozzle	Replace spray nozzles.

APPENDIX A

PROTECTOR PVC

FUME HOOD

COMPONENTS

Illustration A-1 indicate the location of the following service parts:

Protector PVC Hood Replacement Parts

Item	Quantity	Part No.	Description
1A	1	9817000	Valve, Labconco 1/4" Compression Fitting
1B	1	9817001	Valve, Labconco 3/8" Compression Fitting
1C	1	9817002	Valve, Labconco Deionized 1/4" Compression Fitting
1D	1	9817003	Valve, Labconco Deionized 3/8" Compression Fitting
1E	1	9818000	Nut, Valve Mounting. (Labconco)
3	1	9818700 thru 08	Knobs (GRAY, GRN, BLU, ORG, YEL, RED, WHT, BLK, BRN)
4A	1	9818800	Hose Barb, GRAY – (NEUTRAL OR ARGON)-NOT SHOWN
4B	1	9818801	Hose Barb, GREEN - (COLD WATER)-NOT SHOWN
4C	1	9818802	Hose Barb, BLUE – (GAS)-NOT SHOWN
4D	1	9818803	Hose Barb, ORANGE – (AIR)-NOT SHOWN
4E	1	9818804	Hose Barb, YELLOW – (VACUUM)-NOT SHOWN
4F	1	9818805	Hose Barb, RED – (HOT WATER)-NOT SHOWN
4G	1	9818806	Hose Barb, WHITE – (DEIONIZED WATER) NOT SHOWN
4H	1	9818807	Hose Barb, BLACK–(NEUTRAL OR STEAM) NOT SHOWN
4I	1	9818808	Hose Barb, BROWN – (NITROGEN) NOT SHOWN
4J	1	9819000	Nut, Hose Barb - NOT SHOWN
4K	1	4911100	Gooseneck - PVC

Appendix A: Protector PVC Hood Components

Item	Quantity	Part No.	Description
5	1	9825500	Label, Knob (contains all the labels)
6	1	9818900	Lens, Knob
7A	1	9826600, 01, 02	115V Duplex Receptacle (GRAY) Right, Left 4' - 6', Left 8' w/ wires
7B	1	9818200	Cover Plate 115V Duplex
7C	1	9826603, 04, 05	115V GFCI Duplex Receptacle (GRAY) Right, 4' - 6', Left 8' w/ wires
7D	1	9818100	Cover Plate, 115V GFCI
7E	1	9818300	Cover Plate, Blank
8A	1	9721901	Lamp, Fluorescent (T8 x 3') – use on 4' & 8' Hoods
8B	1	9721900	Lamp, Fluorescent (T8 x 4') – use on 5' & 6' Hoods
9	1	9826900	Ballast Assy (used on T8 Slimline)
10A	1	1302300	Switch, Rocker
10B	1	1327500	Switch, Plug (Fills cutout when switch is not used)
11A	1	9818400	Access Cover
11B	1	9825100	Label, Access Cover (includes all three corner labels)
12A	1	9810800	Side Panel, 24" internal deep hoods – NOT SHOWN
12B	1	9810801	Side Panel, 30" internal deep hoods – NOT SHOWN
12C	1	9810802	Side Panel, 36" internal deep hoods – NOT SHOWN
12D	4	1916400	Nut, Retainer #10-24 – NOT SHOWN
12E	4	1885512	Screw, Machine #10-24 x .75 Truss Head Stainless – NOT SHOWN
13A	1	9860000	Air Foil 4'
13B	1	9860002	Air Foil 6'
13C	1	9860003	Air Foil 8'
14	4	1861400	Pulley, Front or Rear, 1-3/16 Dia. – NOT SHOWN
15	2	4949902	Cable, Sash 130" – NOT SHOWN
16	2	9741900	Sheave, (Rear 8') – NOT SHOWN
17	2	1663200	Bumper, Rubber – NOT SHOWN (upper sash bumper)
18	4	9742100	Bronze Bearing, Flanged Rear – NOT SHOWN
19	4	1920100	Clamp, Cable Replacement – NOT SHOWN
20	2	1972100	S-Hook – NOT SHOWN (to attach weight to cable)
21A	1	9826300	Wiring Harness, Main
21B	1	9826400	Wiring Harness, Ballast 115V, 4' - 6'
21C	1	9826700	Wiring Harness, Ballast 115V, 8'
22	1	9807600, 02, 03	Front Panel, 4', 6', 8'
23	1	9724500	Sash Stop Kit
24	1	1487100	Spray Nozzle PVC – NOT SHOWN
25	1	9817001	Washdown Control Valve
26	1	1549100	Plastic Tubing 3/8 OD x 1/4 ID (125 psi W.P.) (Rigid Polyethylene – PE – NOT SHOWN)

Figure A-1

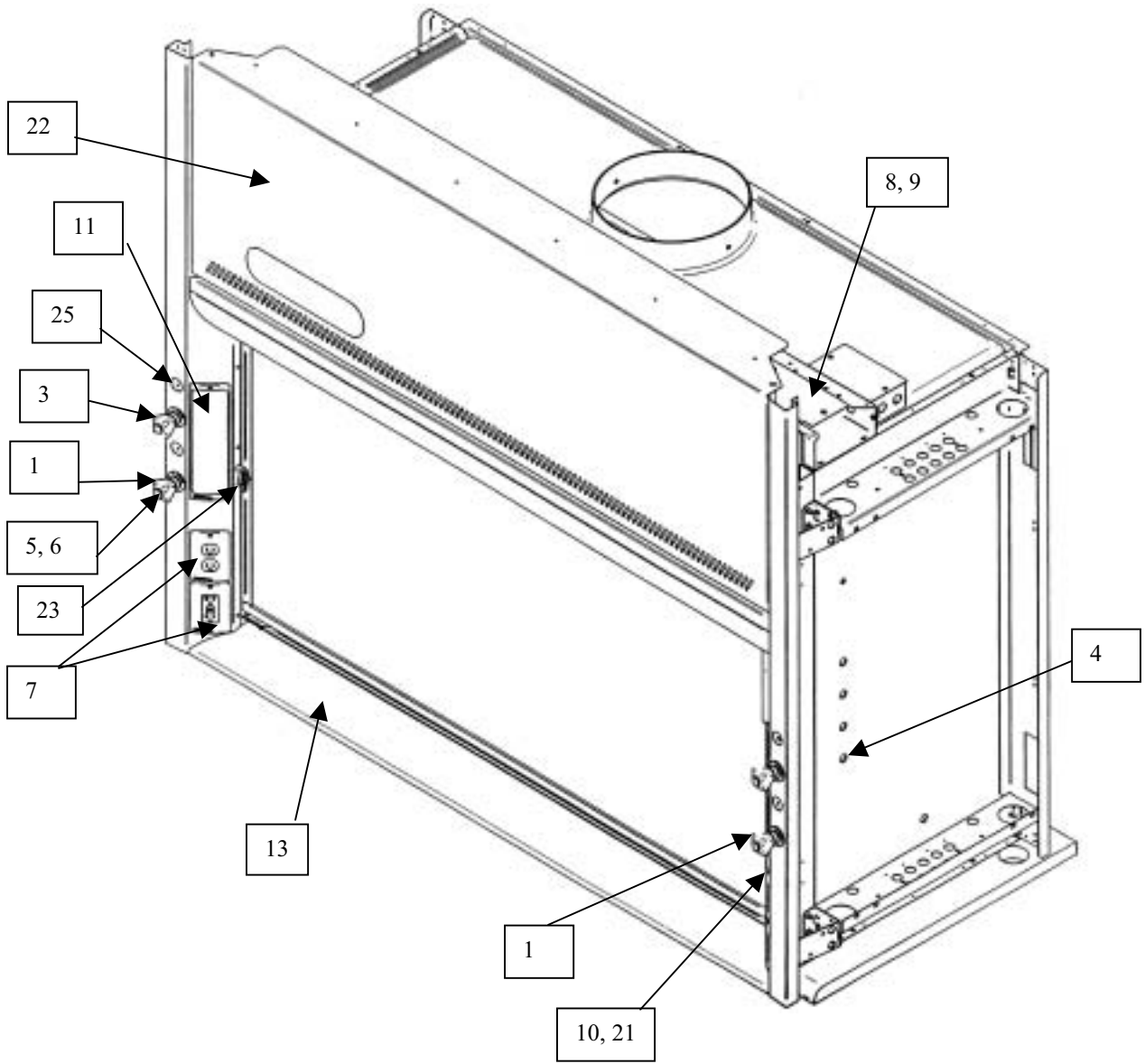

APPENDIX B PROTECTOR PVC HOOD DIMENSIONS

Protector PVC Hood Model Widths

	4'	6'	8'
A	48.00	72.00	96.00
B	38.25	62.25	86.25

Dimensions in inches. CAD layouts available upon request.

Figure B-1

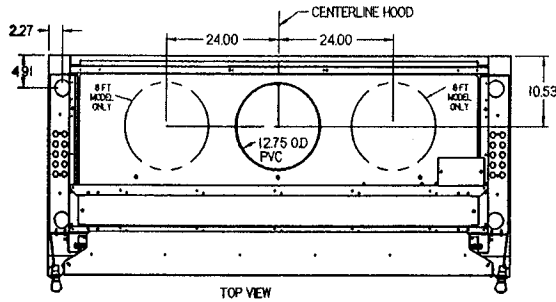

HOOD WIDTH	HOOD WIDTH "A"	HOOD INTERNAL WIDTH "B"
4'	48.00"	38.25"
6'	72.00"	62.25"
8'	96.00"	86.25"

DIMENSIONS SHOWN IN INCHES

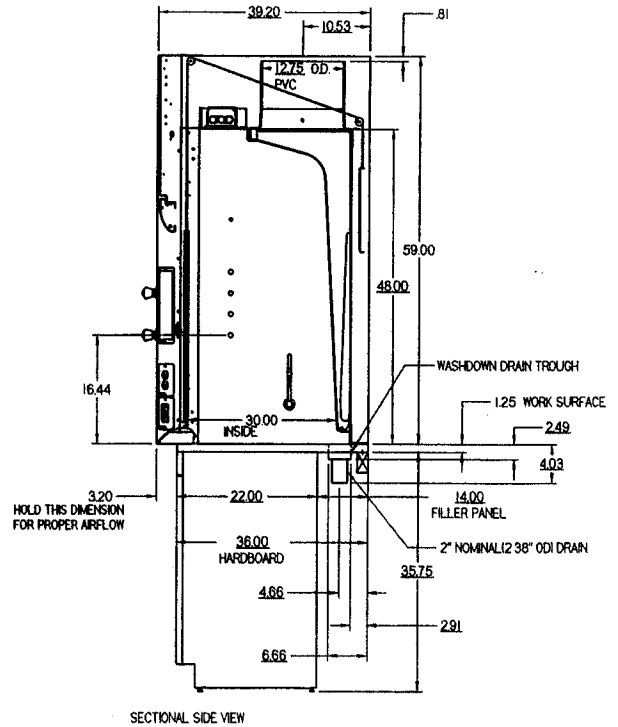
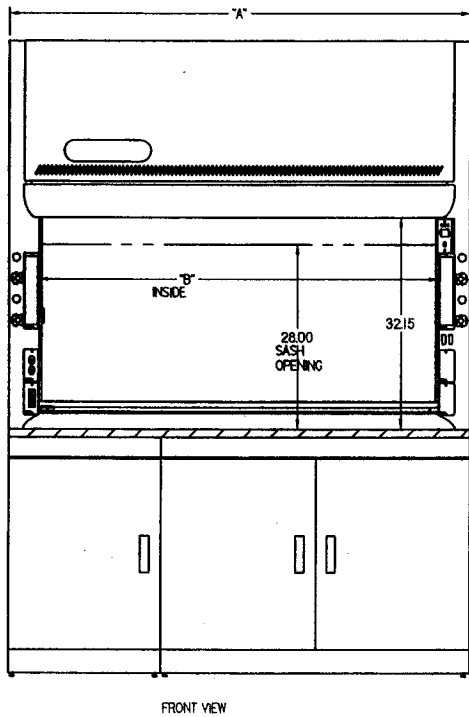

APPENDIX C

PROTECTOR PVC

HOOD

SPECIFICATIONS

Environmental Conditions

- Indoor use only.
- Maximum altitude: 6562 feet (2000 meters).
- Ambient temperature range: 41° to 104°F (5° to 40°C).
- Maximum relative humidity: 80% for temperatures up to 88°F (31°C), decreasing linearly to 50% relative humidity at 104°F (40°C).
- Main supply voltage fluctuations not to exceed $\pm 10\%$ of the nominal voltage.
- Transient over-voltages according to Installation Categories II (Over-voltage Categories per IEC 1010). Temporary voltage spikes on the AC input line that may be as high as 1500V for 115V models and 2500V for 230V models are allowed.
- Used in an environment of Pollution degrees 2 (i.e., where normally only non-conductive atmospheres are present). Occasionally, however, a temporary conductivity caused by condensation must be expected, in accordance with IEC 664.

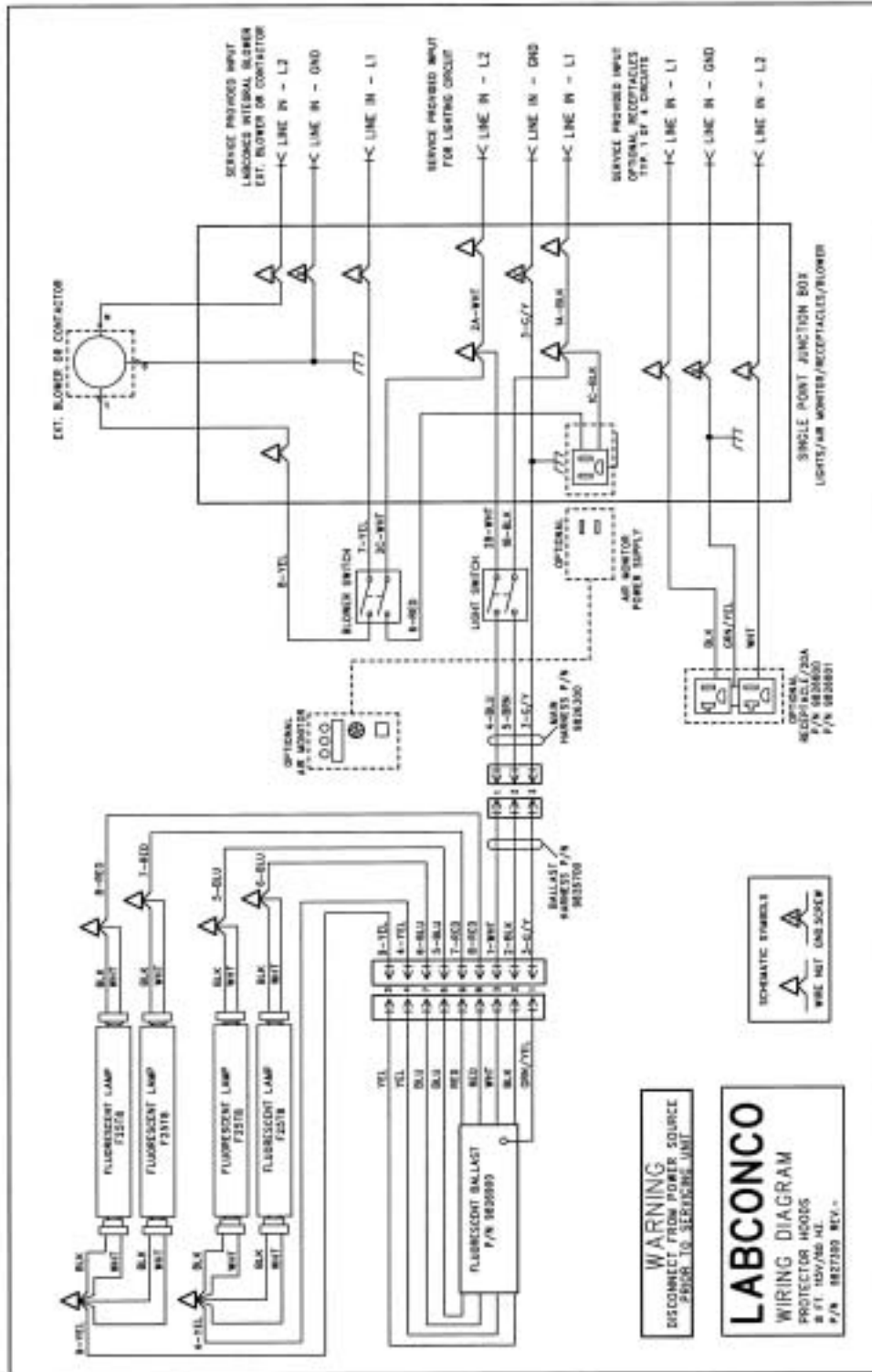

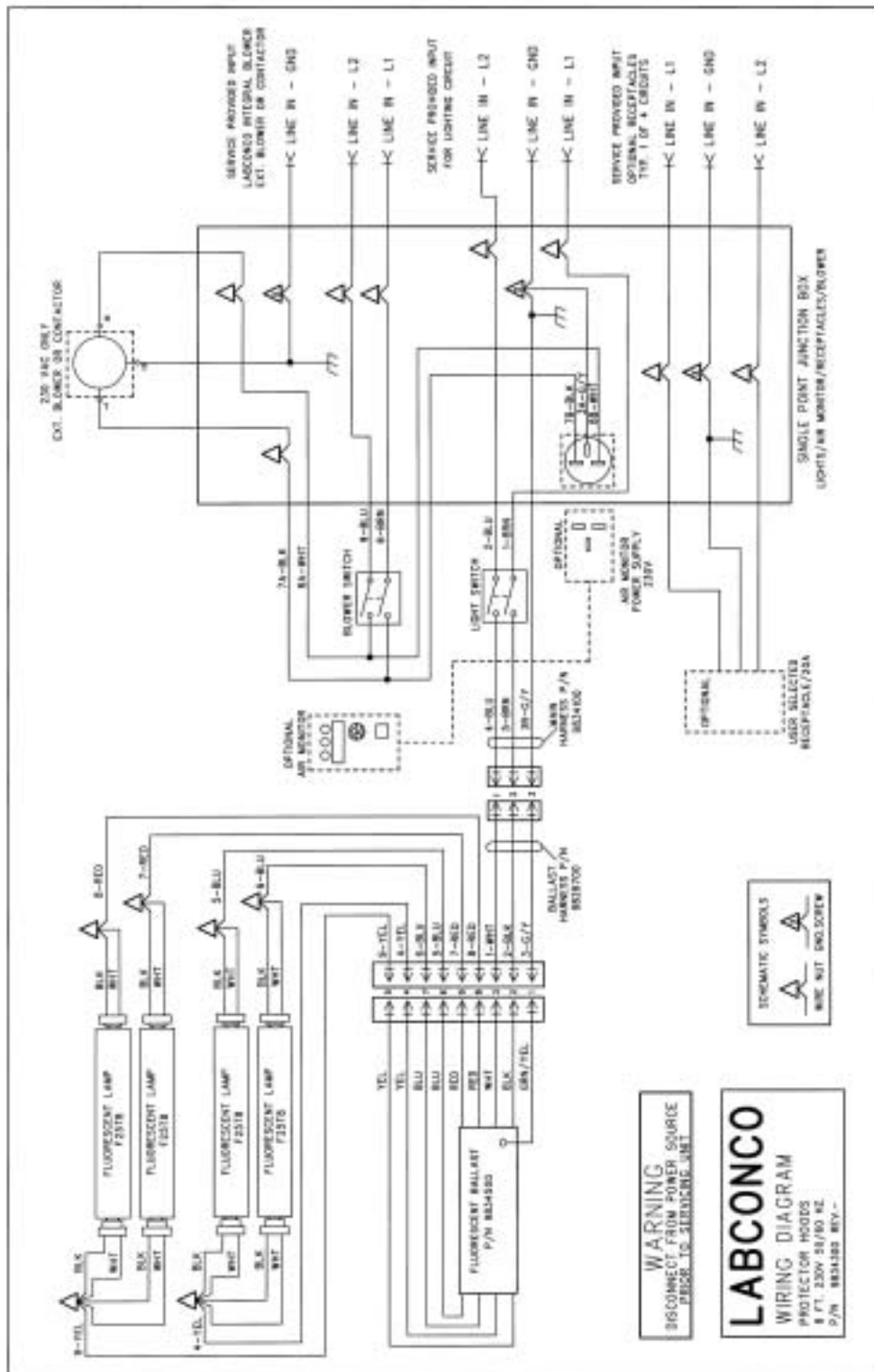

APPENDIX D

REFERENCES

Many excellent reference texts and booklets are currently available. The following is a brief listing:

Laboratory Ventilation Standards

Federal Register 29 CFR Part 1910

Non-mandatory recommendations from "Prudent Practices."

- Fume hoods should have a continuous monitoring device
- Face velocities should be between 60-100 linear feet per minute (lfpm)
- Average 2.5 linear feet of hood space per person

Occupational Health and Safety

U.S. Department of Labor

200 Constitution Avenue N.W.

Washington, DC 20210

(202) 523-1452

Industrial Ventilation-ACGIH

- Fume hood face velocities between 60-100 lfpm
- Maximum of 125 lfpm for PVC Hood hoods
- Duct velocities of 1000-2000 fpm for vapors, gasses and smoke
- Stack discharge height 1.3-2.0 x building height
- Well designed fume hood containment loss, <0.10 ppm

Industrial Ventilation, A Manual of Recommended Practice.

23rd Edition, 1998

American Conference of Governmental Industrial Hygienists

1330 Kemper Meadow drive

Cincinnati, OH 45240-1634

(513) 742-2020

ASHRAE 110-1995 Method of Testing Performance of Fume Hoods

Evaluates fume hood's containment characteristics

- Three part test: Smoke generation, Face velocity profile, Tracer gas release @ 4 liters per minute
- Rated As Manufactured (AM), As Installed (AI) and As Used (AU)

American Society of Heating, Refrigerating, and Air Conditioning Engineers

1791 Tullie Circle N.E.

Atlanta, GA 30329

(404) 636-8400

ANSI Z9.5-1993 Laboratory Standard

Covers entire laboratory ventilation system.

- Vertical stack discharge @ 2000-3000 fpm
- New and remodeled hoods shall have a monitoring device
- Ductless hoods should only be used with non-hazardous materials

American Industrial Hygiene Association

2700 Prosperity Avenue, Suite 250

Fairfax, VA 22031

(703) 849-8888

SEFA 1-1996

- Fume hood face velocities based on toxicity levels of chemicals
 - Class A – 125 to 150 fpm
 - Class B – 80 to 100 fpm
 - Class C – 75 to 80 fpm
- Test method – face velocity profile and smoke generation

Scientific Equipment & Furniture Association

1028 Duchess Drive

McLean, VA 22102

(703) 538-6007

NFPA 45 – 2000 Fire Protection for Laboratories Using Chemicals

- Laboratory hoods should not be relied on for explosion protection
- Exhaust air from fume hoods should not be recirculated
- Services should be external to the hood
- Canopy hoods only for non-hazardous applications
- Materials of construction should have flame spread of 25 or less

NFPA 30 – 1996 Flammable and Combustible Liquids Code

- Approved cabinets may be metal or wood
- Vent location on cabinets are required
- Venting of cabinets not a requirement

National Fire Protection Association

1 Batterymarch Park

P.O. Box 9101

Quincy, MA 02269-9101

(800) 344-3555

General References

American Conference of Governmental Industrial Hygienists. *Industrial Ventilation, A Manual of Recommended Practice, 23rd Edition*, Cincinnati, OH: 1995.

American Conference of Governmental Industrial Hygienists. *1991-1992 Threshold Limit Values for Chemical Substances and Physical Agents and Biological Exposure Indices*. Cincinnati, OH: 1991

ASHRAE Standard Committee. *ASHRAE Standard Atlanta*: ASHRAE Publications Sales Department, 1995

British Standards Institution. *Laboratory Fume Cupboards*. Parts 1, 2 and 3, London: 1990

Department of Labor, Occupational Safety and Health Administration, *29 CFR Part 1910, Occupational Exposures to Hazardous Chemicals in Laboratories, Final Rule*. Vol. 55, No. 21. Washington D.C.:1990

DiBerardinis. L. et al. *Guides for Laboratory Design, Health and Safety Considerations*. Wiley & Sons, 1987

McDermott, Henry, *Handbook of Ventilation for Contaminant Control, 2nd Edition*. Butterworth Publishers, 1985.

Miller, Brinton M. et al. *Laboratory Safety: Principles and Practices*. American Society for Microbiology, Washington, D.C.: 1986

Minimum Acceptable Face Velocities of Laboratory Fume Hoods and Guidelines for their Classification, Oak Ridge National Laboratory #ORNL/TM 7400.

National Fire Protection Association, NFPA 45 *Fire Protection for Laboratories Using Chemicals*, Quincy, MA, 1996.

NIH Guidelines for the Laboratory Use of Chemical Carcinogens. NIH Publication No. 81-2385.

Rayburn, Stephen R. *The Foundation of Laboratory Safety, A Guide for the Biomedical Laboratory*. Springer-Verlag, New York: 1990

Sax, N. Irving and Lewis, JR., Richard J. *Rapid Guide to Hazardous Chemicals in the Workplace*. Van Nostrand Reinhold, 1987.

Schilt, Alfred A. *PVC Hood and Perchlorates*. The G. Frederick Smith Chemical Company, Columbus, OH: 1979.

Scientific Equipment & Furniture Association. *SEFA Laboratory Fume Hoods*. Standard 1996.

Steere, Norman. *CRC Handbook of Laboratory Safety, 2nd Edition*. CRC Press, 1971.

DECLARATION OF CONFORMITY

Application Council Directive(s): 73/23/EEC, 89/336/EEC

Standard(s) to which conformity is declared: EN61010, EN55022, EN50082-1

Manufacturer's Name: Labconco Corporation

Manufacturer's Address: 8811 Prospect Avenue
Kansas City, MO 64132 USA

Importer's Name: See Shipping/Customs Documents*

Importer's Address: See Shipping/Customs Documents for your equipment

Type of Equipment: Laboratory Equipment Protector Laboratory Hoods

Protector PVC Perchloric Acid Fume Hood:

Model No.:	4882300	4' Protector PVC Perchloric Acid Hood
	4882400	4' Protector PVC Acid Digestion Hood
	7282300	6' Protector PVC Perchloric Acid Hood
	7282400	6' Protector PVC Acid Digestion Hood
	9682300	8' Protector PVC Perchloric Acid Hood
	9682400	8' Protector PVC Acid Digestion Hood

Serial No.: Various – See Individual Declaration

Year of Manufacture: 2002 and subsequent

I, the undersigned, hereby declare that the equipment specified above conforms to the above Directive(s) and Standard(s).

See individual Declaration of Conformity which
will be signed by the importer for your country.

Place: _____
(Signature)

Date: _____
(Full Name)

(Position)

*An individual version of this declaration is included with your shipping/customs documentation.

PRODUCT REGISTRATION CARD

By registering your product, you will receive these important benefits: • Warranty Confirmation • Product Registration
• Product Protection • Free LabbyWear™ Merchandise

NAME _____ TITLE _____

DEPARTMENT _____ INSTITUTION _____

ADDRESS _____

CITY/STATE/ZIP/COUNTRY _____

TELEPHONE _____ EXT _____ FAX _____ E-MAIL _____

Which of the following comes closest to describing the type of activity in which you are engaged?

- Quality Control Teaching/Instructional Testing Other (please specify)
 Clinical/Diagnostic Research & Development Production

Of what type organization is your work a part?

- Industrial, Manufacturing, Utility Government (except Medical)
 Educational Institution (except Medical School) Independent, Foundation, Consulting
 Medical, Medical School, Hospital, Public Health Other (please specify)

Which comes closest to describing your scientific discipline?

- Biological Science Inorganic Chemistry Physical Chemistry
 Bio-Chemistry Analytical Chemistry/R & D Engineering or Physics
 Polymer Chemistry Analytical Chemistry/Quality Control Other (please specify)
 Organic Chemistry

Which Protector Laboratory Hood did you purchase?

- XStream™ High Performance Hood Premier™ Fiberglass-Lined Hood XL™ Panel-Lined Hood
 Stainless Steel Radioisotope Hood Stainless Steel Perchloric Acid Hood PVC Hood

Model Number* _____ Serial Number* _____ Date of Installation _____

**Model and serial numbers are located on the lower right-hand corner of the sash and the left-hand corner cover behind the front panel.*

Indicate Labconco accessories purchased with your Protector Hood.

- Acid Storage Cabinet Solvent (flammable) Storage Cabinet Standard Base Cabinet
 Universal Base Stand Other _____

How did you learn about the Protector Hoods?

- Dealer Sales Rep Dealer Catalog Colleague Advertisement
 Labconco Sales Rep Labconco Literature Trade Show Internet/WWW
 Other (please specify) _____

What factors most influenced your decision to purchase a Protector Hood?

(Number up to 3, #1 being the most important)

- ___ Appearance ___ Reputation ___ Service Program ___ Performance Specifications
___ Ease of Operation ___ Safety Features ___ Price ___ Dealer Recommendation
___ Availability ___ Colleague Recommendation ___ Other (please specify) _____

From whom did you purchase your Protector Hood? _____
(DEALER)

Please fold card over, tape edges and mail. No postage is required.

PROTECTOR® LABORATORY HOODS

LabbyWear™ is the official uniform of LABsters everywhere! Be a LABster!

As a token of our thanks for returning your Product Registration Card, we would like to send you the LabbyWear of your choice. Please select from one of the three items listed or collect Labby Bucks and redeem for other LabbyWear merchandise. Then just complete the information requested on the reverse side, fold, tape edges and mail.

- T-shirt.** 100% cotton, short-sleeved, white, with Labby The LABster embroidered on the front left side. Specify unisex size.
 - Large
 - XLarge
- Twill cap.** Pigment-dyed, two-color, with six panels and Labby The LABster embroidered on the front.
- Lunch bag.** Insulated, teal with royal blue accent and Labby The LABster embroidered on the front.
- 10 Labby Bucks** and LabbyWear Catalog.



Labby
The LABster



For more information, please contact us:

[ExpotechUSA](#)
[10700 Rockley Road](#)
[Houston, Texas 77099](#)
[USA](#)

[281-496-0900 \[voice\]](#)

[281-496-0400 \[fax\]](#)

E-mail: sales@expotechusa.com

Website: www.ExpotechUSA.com