

User's Manual

Protector® ClassMate® Laboratory Fume Hoods

Models

69704 Series

69705 Series

69706 Series

69714 Series

69715 Series

69716 Series

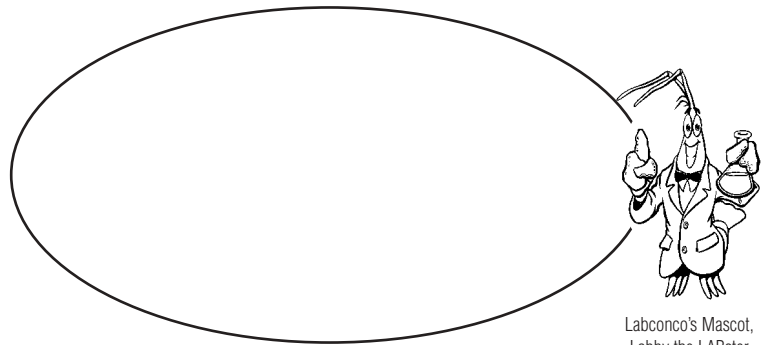

Labconco's Mascot,
Labby the LABster



*Protecting your
laboratory environment*

LABCONCO®

For more information, please contact us:

[ExpotechUSA](#)
[10700 Rockley Road](#)
[Houston, Texas 77099](#)
[USA](#)

[281-496-0900 \[voice\]](#)

[281-496-0400 \[fax\]](#)

E-mail: sales@expotechusa.com

Website: www.ExpotechUSA.com

TABLE OF CONTENTS

CHAPTER 1: INTRODUCTION	1
About This Manual	2
Typographical Conventions	3
Your Next Step	4
CHAPTER 2: PREREQUISITES	7
Location Requirements	8
Support Requirements	8
Exhaust Requirements	8
Electrical Requirements	10
Service Line Requirements	10
Space Requirements	10
CHAPTER 3: GETTING STARTED	11
Unpacking Your Fume Hood	12
Protector ClassMate Components	13
Protector ClassMate Laboratory Hoods Specifications	13
Removing the Shipping Skid	15
Installing the ClassMate on a Supporting Structure & Work Surface	17
Connecting to the ClassMate Hood Exhaust System	18
Connecting the Electrical Supply Source	20
Connecting the Service Lines	22
Sealing the Protector ClassMate Hood	24
Certifying the Protector ClassMate Fume Hood	25
CHAPTER 4: OPERATIONS AND SAFETY PRECAUTIONS	27
Safety Precautions	33
CHAPTER 5: USING YOUR PROTECTOR CLASSMATE	37
Operating the A-Style Combination Sash	38
Operating the Blower	39
Operating the Lights	40
Working in your Protector ClassMate Fume Hood	41

CHAPTER 6: MAINTAINING YOUR CLASSMATE	43
Routine Maintenance Schedule	44
Service Operations	45
CHAPTER 7: MODIFYING YOUR CLASSMATE FUME HOOD	47
Installing Additional Service Fixtures	47
Swageloc (or Parker) Service Fixture	48
Swageloc (or Parker) Service Fixture with Gooseneck	50
WaterSaver Outlet Service Tube Part Numbers	52
Installing Exhaust Adapter for Back to Back Hoods	53
Installing Guardian Digital Airflow Monitor	53
Distillation Grids – Field Installation	57
Installing a 115V Electrical Duplex Outlet	60
CHAPTER 8: TROUBLESHOOTING	63
APPENDIX A: PROTECTOR CLASSMATE COMPONENTS	67
APPENDIX B: PROTECTOR CLASSMATE DIMENSIONS	71
APPENDIX C: PROTECTOR CLASSMATE SPECIFICATIONS	73
APPENDIX D: PROTECTOR CLASSMATE ACCESSORIES	77
Work Surface	77
Cup Sink	78
Storage Cabinet	78
Wood Cabinets	79
Remote Blowers	79
Duct and Accessories	80
Service Fixtures	80
Dual Exhaust Adapter for Back to Back Hoods	80
Digital 335 Airflow Monitor	81
Distillation Grids	81
115V Electrical Duplex Outlet	81
Decorative Rear Panels	82
APPENDIX E: QUICK CHART FOR PROTECTOR CLASSMATE FUME HOOD	83
APPENDIX F: REFERENCES	84
DECLARATION OF CONFORMITY	90

CHAPTER 1

INTRODUCTION

Congratulations on your purchase of a Labconco Protector ClassMate Laboratory Fume Hood. Your Protector ClassMate is designed to protect you. It is the result of Labconco's more than 50 years experience of manufacturing fume hoods, and users like you suggested many of its features to us.

The Labconco Protector ClassMate Fume Hood has been engineered to provide maximum visibility in a classroom laboratory, and effectively contain toxic, noxious, or other harmful materials when properly installed. The Protector ClassMate offers many unique features to enhance safety, performance and visibility. To take full advantage of them, please acquaint yourself with this manual and keep it handy for future reference. If you are unfamiliar with how fume hoods operate, please review *Chapter 4: Theory of Operation and Safety Precautions* before you begin working in the fume hood. Even if you are an experienced fume hood user, please review *Chapter 5: Using Your Fume Hood*, which describes your Protector ClassMate features so that you can use the hood efficiently.

About This Manual

This manual is designed to help you learn how to install, use, and maintain your laboratory fume hood. Instructions for installing optional equipment on your hood are also included.

Chapter 1: Introduction provides a brief overview of the laboratory fume hood, explains the organization of the manual, and defines the typographical conventions used in the manual.

Chapter 2: Prerequisites explains what you need to do to prepare your site before you install your laboratory fume hood. Electrical and service requirements are discussed.

Chapter 3: Getting Started contains the information you need to properly unpack, inspect, install, and certify your laboratory fume hood.

Chapter 4: Theory of Operation and Safety Precautions explains how the Protector ClassMate operates and the appropriate precautions you should take when using the fume hood.

Chapter 5: Using Your Protector ClassMate discusses the basic operation of your fume hood. Information on how to prepare, use and shut down your Protector ClassMate are included.

Chapter 6: Maintaining Your Protector ClassMate explains how to perform routine maintenance on your fume hood.

Chapter 7: Modifying Your Protector ClassMate describes how to install the optional equipment on the fume hood.

Chapter 8: Troubleshooting contains a table of problems you may encounter while using your laboratory fume hood including the probable causes of the problems and suggested corrective actions.

Appendix A: Protector ClassMate Components contains labeled diagrams of all of the components of the fume hoods.

Appendix B: Protector ClassMate Dimensions contains comprehensive diagrams showing all of the dimensions for the 4, 5 and 6 foot models of the laboratory fume hoods.

Appendix C: Protector ClassMate Specifications contains the electrical requirements for laboratory fume hood. Wiring diagrams are also included.

Appendix D: Protector ClassMate Accessories lists the part number and descriptions of all of the accessories available for your laboratory fume hood.

Appendix E: Quick Chart for the Protector ClassMate Hoods provides useful operating specifications.

Appendix F: References lists the various resources available that deal with laboratory fume hoods.

Typographical Conventions

Recognizing the following typographical conventions will help you understand and use this manual:

- Book, chapter, and section titles are shown in italic type (e.g., *Chapter 3: Getting Started*).
- Steps required to perform a task are presented in a numbered format.
- Comments located in the margins provide suggestions, reminders, and references.

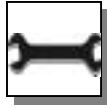

- Critical information is presented in boldface type in paragraphs that are preceded by the exclamation icon. Failure to comply with the information following an exclamation icon may result in injury to the user or permanent damage to fume hood.
- Critical information is presented in boldface type in paragraphs that are preceded by the wrench icon. These operations should only be performed by a trained certifier or contractor. Failure to comply with the information following a wrench icon may result in injury to the user or permanent damage to your hood.
- Important information is presented in capitalized type in paragraphs that are preceded by the pointer icon. It is imperative that the information contained in these paragraphs be thoroughly read and understood by the user.
- A number icon precedes information that is specific to a particular model of laboratory fume hood. The 4' icon indicates the text is specific to the 4-foot wide model. The 5' icon indicates the text is specific to the 5-foot model. The 6' icon indicates the text is specific to the 6-foot model.
- The S icon indicates the text is specific to the standard model.
- The A icon indicates the text is specific to the A-Style Combination Sash Model.

Your Next Step

If your Fume Hood needs to be installed, proceed to *Chapter 2: Prerequisites* to ensure your installation site meets all of the requirements. Then, go to *Chapter 3: Getting Started* for instructions on how to install your laboratory fume hood and make all of the necessary connections.

If you would like to review how laboratory fume hoods operate, go to *Chapter 4: Theory of Operation and Safety Precautions*.

For information on the operational characteristics of your laboratory fume hood, go to *Chapter 5: Using Your Protector ClassMate*.

If your laboratory fume hood is installed and you need to perform routine maintenance on the cabinet, proceed to *Chapter 6: Maintaining Your Protector ClassMate*.

For information on making modifications to the configuration of your unit, go to *Chapter 7: Modifying Your Laboratory Fume Hood*.

Refer to *Chapter 8: Troubleshooting* if you are experiencing problems with your Fume Hood.

CHAPTER 2

PREREQUISITES

Before you install your laboratory fume hood, you need to prepare your site for installation. Carefully examine the location where you intend to install your hood. You must be certain that the area is level and of solid construction. In addition, a dedicated source of electrical power must be located near the installation site.

Carefully read this chapter to learn:

- The location requirements for your installation site.
- The support requirements for your installation site.
- The exhaust requirements for your installation site.
- The electrical power requirements for your installation site.
- The service line requirements for your installation site.
- The space requirements for your installation site.

Refer to *Appendix B: Protector ClassMate Dimensions* for complete fume hood dimensions.

Refer to *Appendix C: Protector ClassMate Specifications* for complete laboratory fume hood electrical and environmental conditions, specifications and requirements.

Location Requirements



The Fume Hood should be located away from traffic patterns, doors, fans, ventilation registers, and any other air-handling device that could disrupt its airflow patterns. All windows in the room should be closed.

Support Requirements



DO NOT locate the fume hood on a cart, dolly, or mobile bench. **ALL** Protector ClassMate installations must be permanent and stationary. The supporting structure usually consists of a base cabinet and chemically resistant work surface. See *Appendix D: Protector ClassMate Accessories*.

Exhaust Requirements

The exhaust duct connection has been designed for 8" nominal pipe (8.625" O.D.) to allow for minimum static pressure loss while operating at 100 fpm face velocities. The 8" exhaust duct also allows for proper transport velocities away from the hood in the 1000 fpm to 2500 fpm range. It is acceptable to combine the air from two hoods with a transition coupling that would basically have two 8" nominal exhaust inlets and one 12" (12.00" O.D.) nominal exhaust outlet. See Appendix D Protector ClassMate Accessories for transition coupling. The proper exhaust volume and static pressure loss are listed next for each hood model:

Catalog Number	Standard Model Description	Total Exhaust at 18" Sash Opening 60% open		
		Face Velocity	Exhaust Volume	Static Pressure Loss
69704-00	48" Hood without fixtures & duplexes	60 fpm	340 CFM	0.09" H ₂ O
		80 fpm	460 CFM	0.16" H ₂ O
		100 fpm	570 CFM	0.24" H ₂ O
69704-01	48" Hood with 4 fixtures & 2 duplexes	60 fpm	340 CFM	0.09" H ₂ O
		80 fpm	460 CFM	0.16" H ₂ O
		100 fpm	570 CFM	0.24" H ₂ O
69705-00	60" Hood without fixtures & duplexes	60 fpm	440 CFM	0.14" H ₂ O
		80 fpm	590 CFM	0.26" H ₂ O
		100 fpm	730 CFM	0.39" H ₂ O
69705-01	60" Hood with 4 fixtures & 2 duplexes	60 fpm	440 CFM	0.14" H ₂ O
		80 fpm	590 CFM	0.26" H ₂ O
		100 fpm	730 CFM	0.39" H ₂ O
69706-00	72" Hood without fixtures & duplexes	60 fpm	540 CFM	0.19" H ₂ O
		80 fpm	710 CFM	0.33" H ₂ O
		100 fpm	890 CFM	0.51" H ₂ O
69706-01	72" Hood with 4 fixtures & 2 duplexes	60 fpm	540 CFM	0.19" H ₂ O
		80 fpm	710 CFM	0.33" H ₂ O
		100 fpm	890 CFM	0.51" H ₂ O
Total Exhaust at 50% Open Sash Horizontally or Vertically				
Catalog Number	Reduced Air Volume Model Description	Face Velocity	Exhaust Volume	Static Pressure Loss
69714-00	48" Single Sash Hood without monitor, fixtures & duplexes	60 fpm	280 CFM	0.06" H ₂ O
		80 fpm	380 CFM	0.11" H ₂ O
		100 fpm	470 CFM	0.16" H ₂ O
69714-01	48" Single Sash Hood with digital airflow monitor, 4 fixtures & 2 duplexes	60 fpm	280 CFM	0.06" H ₂ O
		80 fpm	380 CFM	0.11" H ₂ O
		100 fpm	470 CFM	0.16" H ₂ O
69715-00	60" A-Style Sash Hood without monitor, fixtures & duplexes	60 fpm	330 CFM	0.08" H ₂ O
		80 fpm	440 CFM	0.14" H ₂ O
		100 fpm	550 CFM	0.22" H ₂ O
69715-01	60" A-Style Sash Hood with digital airflow monitor, 4 fixtures & 2 duplexes	60 fpm	330 CFM	0.08" H ₂ O
		80 fpm	440 CFM	0.14" H ₂ O
		100 fpm	550 CFM	0.22" H ₂ O
69716-00	72" A-Style Sash Hood without monitor, fixtures & duplexes	60 fpm	410 CFM	0.11" H ₂ O
		80 fpm	550 CFM	0.20" H ₂ O
		100 fpm	680 CFM	0.30" H ₂ O
69716-01	72" A-Style Sash Hood with digital airflow monitor, 4 fixtures & 2 duplexes	60 fpm	410 CFM	0.11" H ₂ O
		80 fpm	550 CFM	0.20" H ₂ O
		100 fpm	680 CFM	0.30" H ₂ O

Proper blower selection can be determined from these exhaust requirements and the total system static pressure loss. Consult Labconco Ventilation Ventures Team if you need help sizing a blower.

Electrical Requirements

The Protector ClassMate Hood models feature internal wiring for the fluorescent light assembly and light switch. All hood models with 115V, 60 Hz duplex outlets are terminated at the internal boxes for hook-up by a qualified electrician. The blower switch, and light switch wires are also terminated at the internal boxes for hook-up by a qualified electrician. Refer to *Chapter 3: Getting Started* and *Appendix C: Protector ClassMate Specifications* for the wiring diagram for proper electrical installation. All models have 115 VAC, 60 Hz, 12 Amp requirements.

Service Line Requirements

All service lines to the laboratory fume hood should be ¼ inch outside diameter, copper (brass for gas), and equipped with an easily accessible shut-off valve, should disconnection be required. If the service line pressure exceeds 40 PSI, it must be equipped with a pressure regulator to reduce the line pressure.

On hood models with service fixtures, three of the fixtures are pre-plumbed using 1/4" copper tubing between both the valve, and the hose connector. The upper right hand position fixture is pre-plumbed using 1/4" brass tubing between both the valve, and the hose connector for usage with natural gas. The supply lines shall be installed from under the hood and terminated at the valves by a qualified contractor.

Space Requirements

The dimensions for the different models are shown in *Appendix B: Protector ClassMate Dimensions*.

Your Next Step

After you have determined that the location you have selected accommodates the installation and operational requirements of your fume hood, you are ready to begin installation. Proceed to *Chapter 3: Getting Started*.

CHAPTER 3

GETTING STARTED

Now that the site for your laboratory fume hood is properly prepared, you are ready to unpack, inspect, install, and certify your unit. Read this chapter to learn how to:

- Unpack and move your Protector ClassMate Hood.
- Set up the fume hood with the supporting structure and work surface.
- Connect to an exhaust system.
- Connect the electrical supply source.
- Connect the service lines.
- Sealing the Protector ClassMate Hood.
- Arrange certification of your Protector ClassMate Hood.

Depending upon which model you are installing, you may need common plumbing and electrical installation tools in addition to 5/16", 3/8", 7/16", and 1/2" wrenches, ratchets, sockets, a nut driver set, a flat-blade screwdriver, a Phillips screwdriver, and a carpenter level to complete the instructions in the chapter.



The Protector ClassMate models weigh between 400 – 700 lbs. (182-318 kg). The shipping skid allows for lifting with a mechanical lift truck or floor jack. If you must lift the fume hood manually, use at least six (6)

people and follow safe-lifting guidelines. Normally, the fume hood can slide off a hydraulic lift and be placed into position on top of the work surface.

Unpacking Your Laboratory Fume Hood

The United States Interstate Commerce Commission rules require that claims be filed with the delivery carrier within fifteen (15) days of delivery.

Carefully remove the shrink-wrap on your fume hood and inspect it for damage that may have occurred in transit. If your unit is damaged, notify the delivery carrier immediately and retain the entire shipment intact for inspection by the carrier.

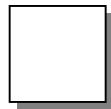

DO NOT RETURN GOODS WITHOUT THE PRIOR AUTHORIZATION OF LABCONCO. UNAUTHORIZED RETURNS WILL NOT BE ACCEPTED.

IF YOUR HOOD WAS DAMAGED IN TRANSIT, YOU MUST FILE A CLAIM DIRECTLY WITH THE FREIGHT CARRIER. LABCONCO CORPORATION AND ITS DEALERS ARE NOT RESPONSIBLE FOR SHIPPING DAMAGES.

Do not discard the shipping skid or packing material for your fume hood until you have checked all of the components and installed and tested the unit.

Do not remove the fume hood from its shipping skid until it is ready to be placed into its final location. Move the unit by placing a flat, low dolly under the shipping skid, or by using a floor jack.



Do not move the hood by tilting it onto a hand truck.

Protector ClassMate Components

Labconco manufactures Protector ClassMate Fume Hoods for operation with vertical rising sashes or combination A-Style sashes. Each of the hoods is available in 4-foot, 5-foot and 6-foot models. Models are all 115V.

Locate the hood model you received in the following group of tables. Verify that the components listed are present and undamaged.

Protector ClassMate Laboratory Hoods

General Specifications for All Models

By-pass airflow design. Frame, airfoil and trough constructed of epoxy-coated steel and aluminum. Trough extends 1.25" below hood. Tempered safety glass sash, sides, back and baffle. Factory wired fluorescent light, blower and light switches. Interior depth of 25.5" and height of 48". Interior cover plates for access to plumbing. Factory prepared for up to 4 service fixtures with an additional 4 in the base cabinet, two duplex electrical receptacles and airflow monitor, 8" diameter exhaust collar. **Blower, work surface and base cabinets are required (not included).** For operation on 115 volts, 60 Hz, 15 amps. Exterior depth is 32". Exterior height is 59" (overall height including trough is 60.25").

Additional specifications for Standard Models

Sash provides maximum visibility of 39" high. Vertical rising sash with anti-racking shaft moves from closed to 18" operating height. Sash moves up past the sash stop for loading. Fixtured models include two electrical duplex receptacles and four service fixtures pre-plumbed with copper tubing. Upper right fixture is plumbed with brass for gas connection.

Catalog #	Hood Description
69704-00	48" Hood without fixtures & duplexes
69704-01	48" Hood with 4 fixtures & 2 duplexes
69705-00	60" Hood without fixtures & duplexes
69705-01	60" Hood with 4 fixtures & 2 duplexes
69706-00	72" Hood without fixtures & duplexes
69706-01	72" Hood with 4 fixtures & 2 duplexes

Additional Specifications for Models with Combination A-Style Sashes

4' hoods have a single vertical rising sash; 5' and 6' hoods have combination horizontal sliding/vertical-rising sashes. Static viewing panel above moveable sash provides 39" viewing height. Airfoil is yellow epoxy-coated steel. Fixtured models include factory installed Guardian Digital Airflow Monitor, two electrical duplex receptacles, and four WaterSaver service fixtures plumbed with copper tubing. Upper right fixture is plumbed with brass for gas connection.

Catalog #	Hood Description
69714-00	48" Single Sash Hood without monitor, fixtures & duplexes
69714-01	48" Single Sash Hood with digital airflow monitor, 4 fixtures & 2 duplexes
69715-00	60" A-Style Sash Hood without monitor, fixtures & duplexes
69715-01	60" A-Style Sash Hood with digital airflow monitor, 4 fixtures & 2 duplexes
69716-00	72" A-Style Sash Hood without monitor, fixtures & duplexes
69716-01	72" A-Style Sash Hood with digital airflow monitor, 4 fixtures & 2 duplexes

Plus the Following:

<u>Part #</u>	<u>Component Description</u>
69852-00	User's Manual

If you did not receive one or more of the components listed for your fume hood, or if any of the components are damaged, contact Labconco Corporation immediately for further instructions.

Removing the Shipping Skid



LEAVE THE FUME HOOD ATTACHED TO ITS SHIPPING SKID UNTIL IT IS AS CLOSE TO ITS FINAL LOCATION AS POSSIBLE. MOVE THE UNIT BY USING A SUITABLE FLOOR JACK, OR BY PLACING A FURNITURE DOLLY UNDERDNEATH THE SKID. DO NOT MOVE THE HOOD BY TILTING IT ONTO A HAND TRUCK.

After you verify the fume hood components, move your hood to the location where you want to install it. Then, follow the steps listed next to remove the shipping skid from your unit.

Follow the instructions as shown in Figures 3-1, 3-2, and 3-3

1. Remove and discard the cardboard corner posts (Figure 3-1).
2. Remove strap that secures sash. For A-Style combination sashes disassemble from skid and attach to hood per Step 7.

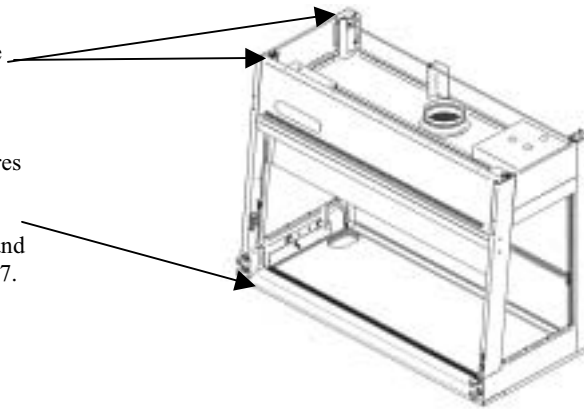

Figure 3-1

3. Remove the access panels and after removal, save the access panels and hardware for re-attachment. (Figure 3-2)
4. Remove and discard the screws and washers that are located behind the access panel that attaches the hood to the skid. Not Shown.
5. Re-attach access panels from Step 3. (Figure 3-2).

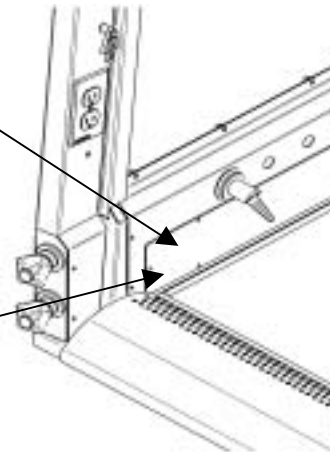

Figure 3-2

6. Ensure that the cable on each side is properly seated in the front and rear pulleys. (Figure 3-3). Releasing the sash weights with the cables improperly positioned can cause damage.

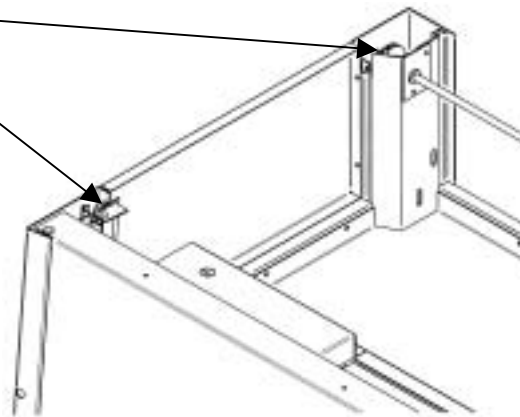

Figure 3-3



7. **IMPORTANT: A-Style Combination Sash version install horizontal glass sashes before Step 8.**

8. Release the load on the bolt by lifting up slightly on the cable. Remove the bolts straight out of the rear posts. 2 bolts per each side to be removed. (Figure 3-3)
9. Sash shall raise smoothly.

Install the Protector ClassMate Hood on A Supporting Structure and Work Surface



**The Protector ClassMate is heavy!
Use caution when lifting or moving the
unit.**

When installing the Protector ClassMate Fume Hood onto a chemically resistant work surface or benchtop, ensure that the structure can safely support the combined weight of the fume hood and any related equipment. The work surface should be at least as wide as the unit and 25-7/8 inches deep to properly support the unit.



WARNING: It is important to support the rear of the hood. Prior to setting the hood, install the cross supports after the base cabinets and work surface are leveled. The wood cross support provides support for the bottom of the work surface.

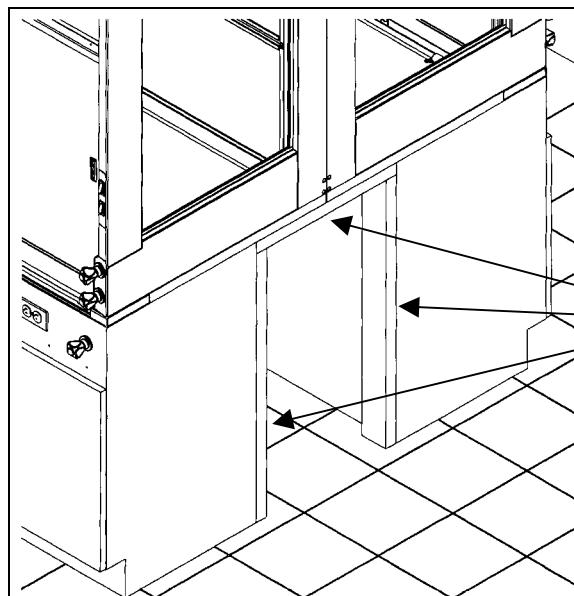

Figure 3-4

Cross
Supports

The following are instructions for mounting a 2 x 4 cross support:

1. Level the base cabinets and the work surface.
2. Scribe a line on the wall or back of the base cabinet to locate the support under the work surface.
3. Mount the support by attaching it to the wall or base cabinet.
4. Place the hood on top of the work surface and cross support.

The work surface should be smooth and durable, and made from a chemically resistant epoxy resin. The surface should be nonporous and resistant to the acids, solvents, and chemicals used in conjunction with the Protector ClassMate Fume Hood. The work surface should also contain a spillway for containing primary spills.

See *Appendix D: Protector ClassMate Accessories* for the work surfaces, and storage cabinets.

Connecting to the Protector ClassMate Hood Exhaust System



WARNING: The weight of the exhaust ductwork system must be supported independently of the hood superstructure. Do not allow this weight to be supported by the hood structure as damage to the unit may occur.

Figure 3-5

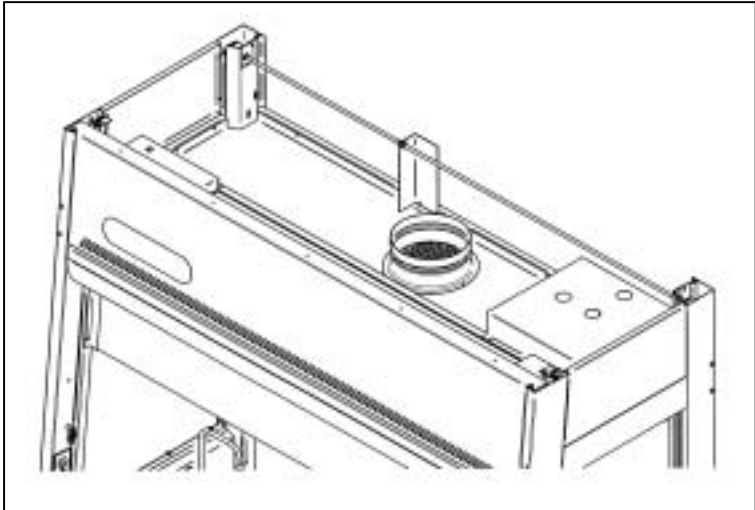

The exhaust connection should be installed by a qualified HVAC contractor.

Figure 3-6

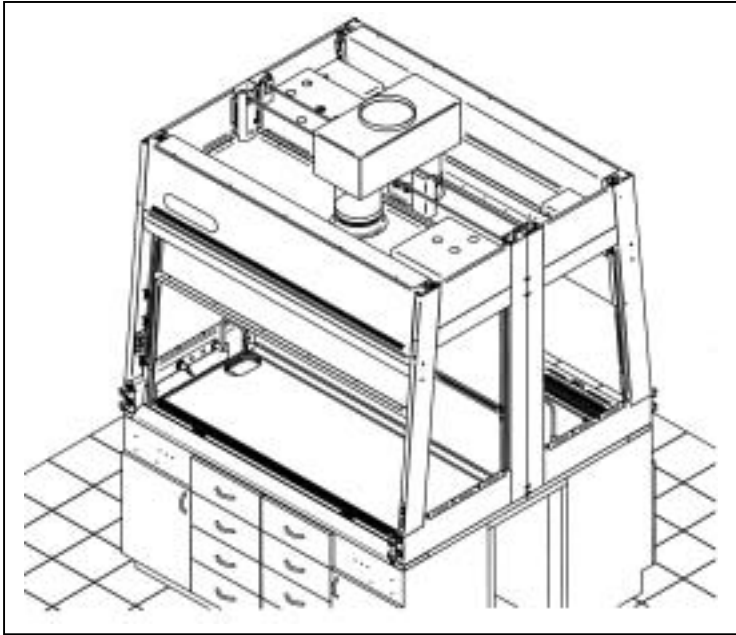

The exhaust connection on your hood has been designed for 8" nominal pipe (8.62" O.D.) to allow for minimum static pressure loss with proper transport velocities away from the hood. It is acceptable to combine the air from two back to back hoods with a 12" x 8" x 8" dual exhaust adapter that would basically have two 8" nominal exhaust inlets and one 12" (12.00" O.D.) nominal exhaust outlet. See *Appendix D: Protector ClassMate Accessories* for dual exhaust adapter. Refer to exhaust requirements in *Chapter 3 Fume Hood Components* on exhaust volumes for your model to properly size the blower. Consult Labconco Ventilation Ventures Team should you require help sizing your blower for the exhaust volume and total system static pressure loss.

Connecting the Electrical Supply Source to the Protector ClassMate Fume Hood

Prior to connecting any electrical wiring to the fume hood structure, refer to the hood identification plate for the proper electrical characteristics of your specific model.



WARNING: The building electrical supply system for Protector ClassMate Hoods should include overload protection. A switch or circuit breaker should be in close proximity to the equipment and within easy reach of the operator. The switch or circuit breaker is to be marked as the disconnecting device for the equipment.

The identification plate, model number, serial number, and electrical connection boxes are accessible from the front of the fume hood by removing the front panel.

The remote blower style Protector ClassMate Hood is fully wired internally for 115 Volt, 60 Hz, 15 Amp electrical service. The number of circuits varies depending on the model. The Protector ClassMate Hood models do not feature internal wiring or electrical components excluding the fluorescent light assembly. All of the hood's electrical connections are terminated at the internal boxes for hook-up by a qualified electrician. The specific internal boxes for hook-up are the lights, blower, and 115V, 60 Hz, 15A duplex outlets. Refer to the wiring diagram for your Protector ClassMate in *Appendix C: Protector ClassMate Fume Hood Specifications*.

Figure 3-7

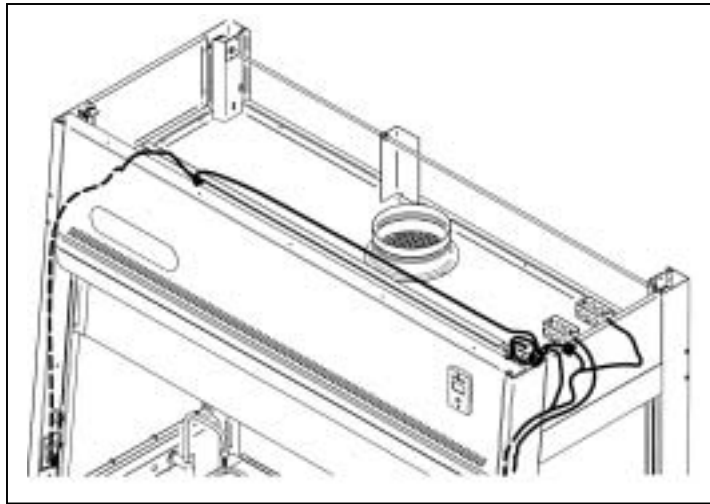

All wiring for the enclosure MUST be performed by a licensed electrician and conform to all local codes. In most cases, the hood will require the use of shielded conduit to protect the wiring into the hood. The grounding connection shall not be made to the terminal box cover.

The fluorescent light has been mounted outside the top liner panel assembly and is sealed from any vapors used inside the hood structure. To change the fluorescent light bulbs in your hood, you must first remove the front panel from the hood. Next remove the screws holding down the light reflectors. Remove the light reflectors and slide them away temporarily.

The fluorescent light assembly is now fully exposed and ready for service. While the fixture is in this position, replace the defective bulbs, and reassemble.

Connecting the Service Lines to the Protector ClassMate Fume Hood

The hoods with service fixtures have been fully plumbed for up to four valves on the hood for your installation convenience. Supply tubing shall be provided by the qualified contractor. Tubing is to extend through the work surface to make connections to the individual supply lines in your facility.

On standard models three of the fixtures are pre-plumbed using 1/4" copper tubing between the valve, and hose connector. The upper right hand position fixture is pre-plumbed using 1/4" brass tubing between the valve, and hose connector for use with natural gas.

Figure 3-8

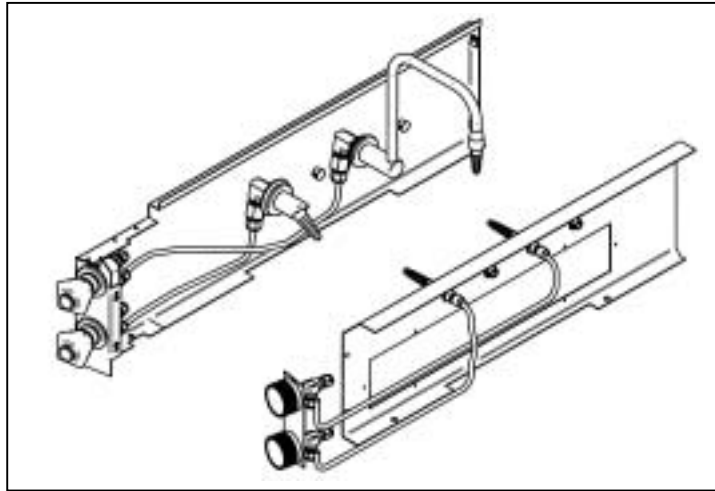

To install the supply tubing, follow these steps:

1. Remove the valve service plate and outlet fitting access covers by loosening their individual screws. The valve body and service areas will now be fully exposed.
2. Ensure that the tubing is $\frac{1}{4}$ inch outside diameter, soft metal, and that the end has been deburred completely. (See *Appendix D Service Fixture Accessories* to order 5.5' of supply tubing 48899-00 or 49211-00 gas).
3. Route the tubing from under the fume hood through the slot in the work surface.



Make sure that the tube routing will not contact any electrical wires.

4. Make sure that the tube fitting on the valve is loose, but do not remove it. Look inside the fitting to make sure the tube ferrules are there.
5. Push the tube into the fitting until it is properly seated. The tube will go approximately $\frac{3}{4}$ inch into the fitting.
6. Tighten the tube fitting hand tight and then using a $\frac{7}{16}$ inch wrench, tighten it at least $\frac{3}{4}$ turn more.

7. Close the service valve in the Protector ClassMate Fume Hood and then slowly open the shutoff valve on the service line.



NOTE: Inspect all fittings for leakage. Tighten the tube nut slightly if needed.



CAUTION: Do not use oxygen with service fixtures as supplied with this hood. Contact Labconco for oxygen fixture information.

Should access to the hood plumbing fixture bodies be required, remove the individual valve service plates on the corner covers by loosening their individual screws. The valve body will now be fully exposed for any service work that may be necessary. The service fixtures supplied on your laboratory hood are designed for use with the following services:

- Air
- Cold Water
- Hot Water
- Natural Gas (upper right)
- Vacuum



WARNING: Contact Labconco Corporation directly before using any service other than those listed above in these valves to assure full compatibility.



CAUTION: Natural gas should be used only in the service fixture that has been pre-plumbed with brass tubing. Sulfur content of the gas could cause deterioration of standard copper supply lines.

Sealing the Protector ClassMate Hood

When the hood has been set in place, ducted, wired, and plumbed, it should be sealed at the work surface. The sealing of the hood structure to the work surface will prevent spilled materials from collecting under the

walls of the hoods. Materials such as silicone sealants may be used to seal the hood structure.

Certifying the Protector ClassMate Fume Hood

The combination of your laboratory hood, exhaust ductwork, and exhaust blower enables you flexibility to change the airflow generated across the sash opening on the hood. To determine the actual face velocity through the sash opening, airflow velocity readings will need to be taken. This should be done across the sash opening of the hood in accordance with the *Industrial Ventilation Manual* section on laboratory hoods. Labconco recommends an average face velocity through the reduced hood opening of 60 to 100 feet per minute. Reference airflow's for your particular model in *Chapter 3 Fume Hood Components*.

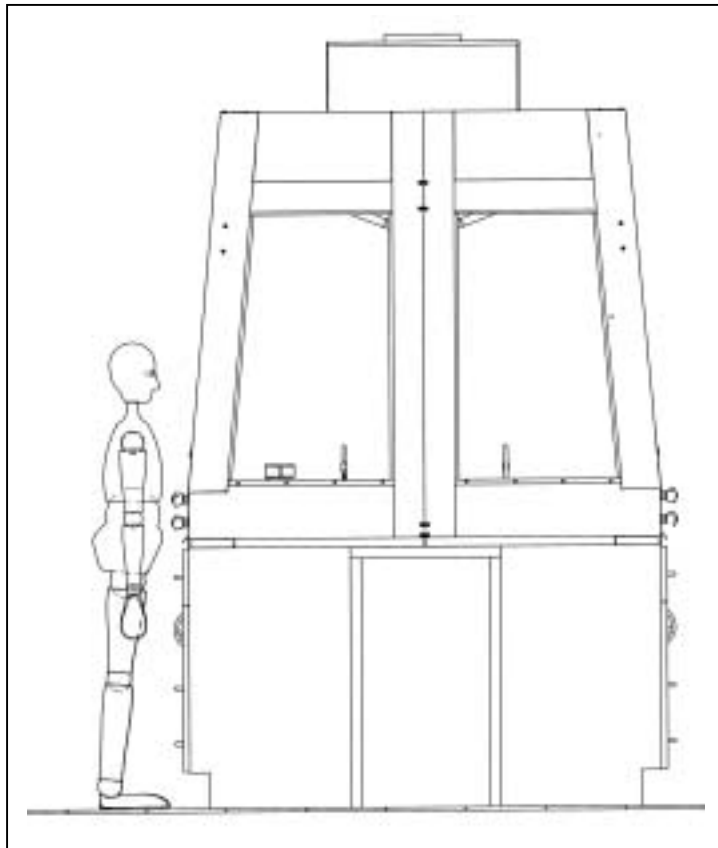

Figure 3-9

Your Protector ClassMate Fume Hood has been certified at the factory per ASHRAE 110-1995. In this procedure Labconco tests the “as manufactured” hood for average face velocity readings, smoke visualization, and tracer gas containment readings less than 0.1 part per million (PPM) with a mannequin. For “field use” ASHRAE testing contact Labconco Ventilation Ventures Team for a certified on-site contractor.



NOTE: Face velocity profiles and smoke testing should be done periodically to ensure proper safe performance.

Your Next Step

After your Fume Hood has been installed and certified, you are ready to proceed to *Chapter 4: Theory of Operation and Safety Precautions*.

CHAPTER 4

THEORY OF

OPERATION AND

SAFETY

PRECAUTIONS

Theory of Operation:

The Protector® ClassMate Laboratory Hood is designed to meet the needs of the science instructor. Clear back and sides and taller front viewing window provide enhanced visibility for the instructor conducting chemistry demonstrations or observing students using the hood. The ergonomic inclined front promotes additional visibility into the laboratory. The clear back also does not obstruct visibility when hoods are placed back-to-back in an island configuration. A fully featured by-pass hood with baffle and airfoil, this hood maintains safe airflow while sash opening restriction conserves energy. The Protector ClassMate Hood is offered in 4', 5', and 6' widths. Additional energy saving A-Style Combination Sash models are also available. The hood features by-pass airflow design that allows the hood face velocity to remain relatively stable as the sash is closed. Airflow is diverted

behind the front and under the airfoil to help control fluctuations in face velocity, which occur as the sash is closed.

The major components in Protector ClassMate Laboratory Hoods are outlined as follows and in Figure 4-1, and Figure 4-1A:

1. **Clear, tempered safety glass sides, back and baffle provide maximum visibility.** All glass components except sashes are removable for cleaning. Visibility up to 45" on sides and back.
2. **Unique sash provides maximum visibility of 39" high while conserving energy.** Vertical-rising sash may be raised from a closed to 18" operating height. Exhaust volume, and blower sizing is based on the 18" height. For loading and cleaning, the sash raise up above the sash stop.
3. **Anti-racking shaft** provides smooth vertical sash movements.
4. **By-pass airflow design** ensures relatively stable face velocities.
5. **Large usable interior work depth of 26" and interior height of 48"** provide ample working space.
6. **Baffle** directs airflow to the rear of the interior to provide efficient airflow. The baffle may be removed or pivoted down for cleaning purposes only.
7. **Tissue Screen** located directly below the exhaust outlet prevents debris from potentially damaging the remote blower.
8. **Interior cover plates** are removable for easy access to plumbing.
9. **Lift-away front panel** provides easy access to electrical wiring, sash weights, and lighting fixtures.
10. **Energy efficient fluorescent lighting** is located behind a tempered safety glass shield mounted to the top of the hood interior. The factory

wired light is serviceable from outside the hood cavity.

11. **Low mounted, factory wired light and blower switches** are ADA compliant.
12. **Ergonomic airfoil** allows air to sweep work surface for maximum containment and provide a Patented Clean Sweep™ on the upper surface to provide maximum containment.
13. **Low profile trough** below airfoil contains spills. The trough is the same depth as the work surface (1.25") and requires no cabinet overhang.
14. **Streamlined corner posts** provide maximum visibility.
15. **All hoods are factory prepared for up to 8 service fixtures** (four controlled from the front of the hood and four from the base cabinet). Four service fixtures are factory installed on fixtured models. ADA compliant fixtures are fully plumbed with copper tubing. The upper right fixture is brass for gas service. Because the fixtures are remotely controlled, they can be used regardless of sash position.
16. **Duplex electrical receptacles** are mounted on the right and left fixture panels on fixtured models to allow convenient and safe connections. Receptacles are factory wired to hood junction boxes.
17. **Shipped fully assembled** and eliminates the need for costly onsite assembly.
18. **Accessory Guardian™ Digital Airflow Monitor** continuously monitors face velocity. An audio/visual alarm alerts the user to low airflow conditions. The front panel can be factory prepared to accommodate the Guardian Digital Airflow Monitor (sold separately).
19. **Energy Reducing A-Style Combination Sash Models.** See Figure 4-1A. Clear static viewing panel above the sash frame has a 39" viewing height permitting the hood to be mounted in a low or high position to accommodate persons of

different heights and still maintain the same visual accessibility. The 4' hoods have a single vertical rising sash; 5' and 6' hoods have combination horizontal sliding/vertical rising sashes. These combination sashes allow the operator to use the hood with sashes either half open vertically or horizontally to conserve energy. Two sets of integral sash stops prevent raising the vertical sash above the half-open and fully closed positions unless manually defeated by the operator.

20. **Epoxy coated steel sash enclosure** located behind the front panel prevents laboratory exposure to contaminated interior sash surfaces for energy saving A-Style models only.
21. **Frame of epoxy coated steel and aluminum** is durable and corrosion resistant.
22. **Exhaust Connection.** The hood features 8" (8.62" O.D. pipe) molded exhaust connections sized to allow for a minimum static pressure loss through the hood structure while providing a good transport velocity through the exhaust system. Dual exhaust Adapter is sold separately.
23. **Accessory solid Epoxy Work Surface** is dished to contain spills. Work surface is sold separately.

Figure 4-1

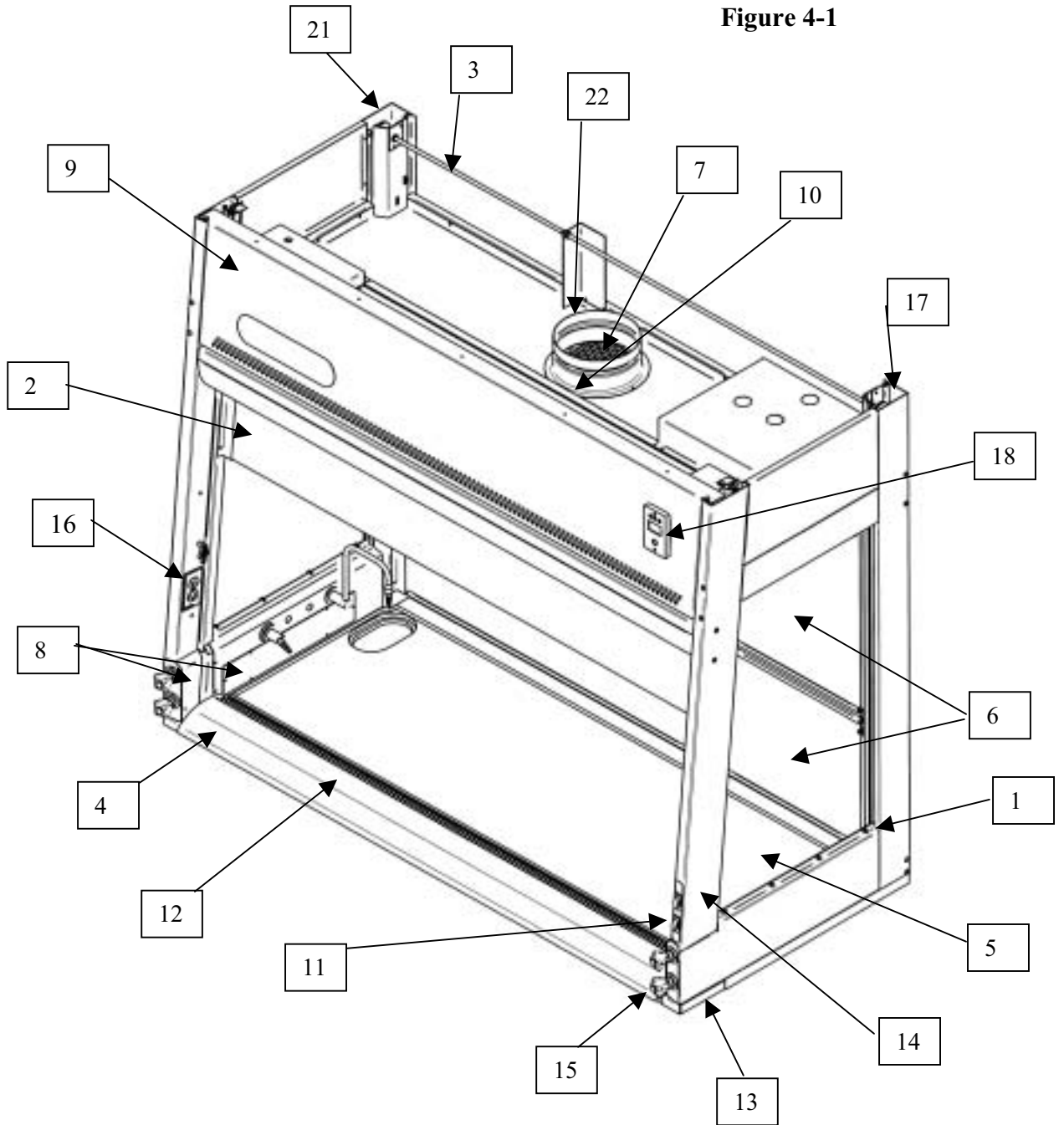
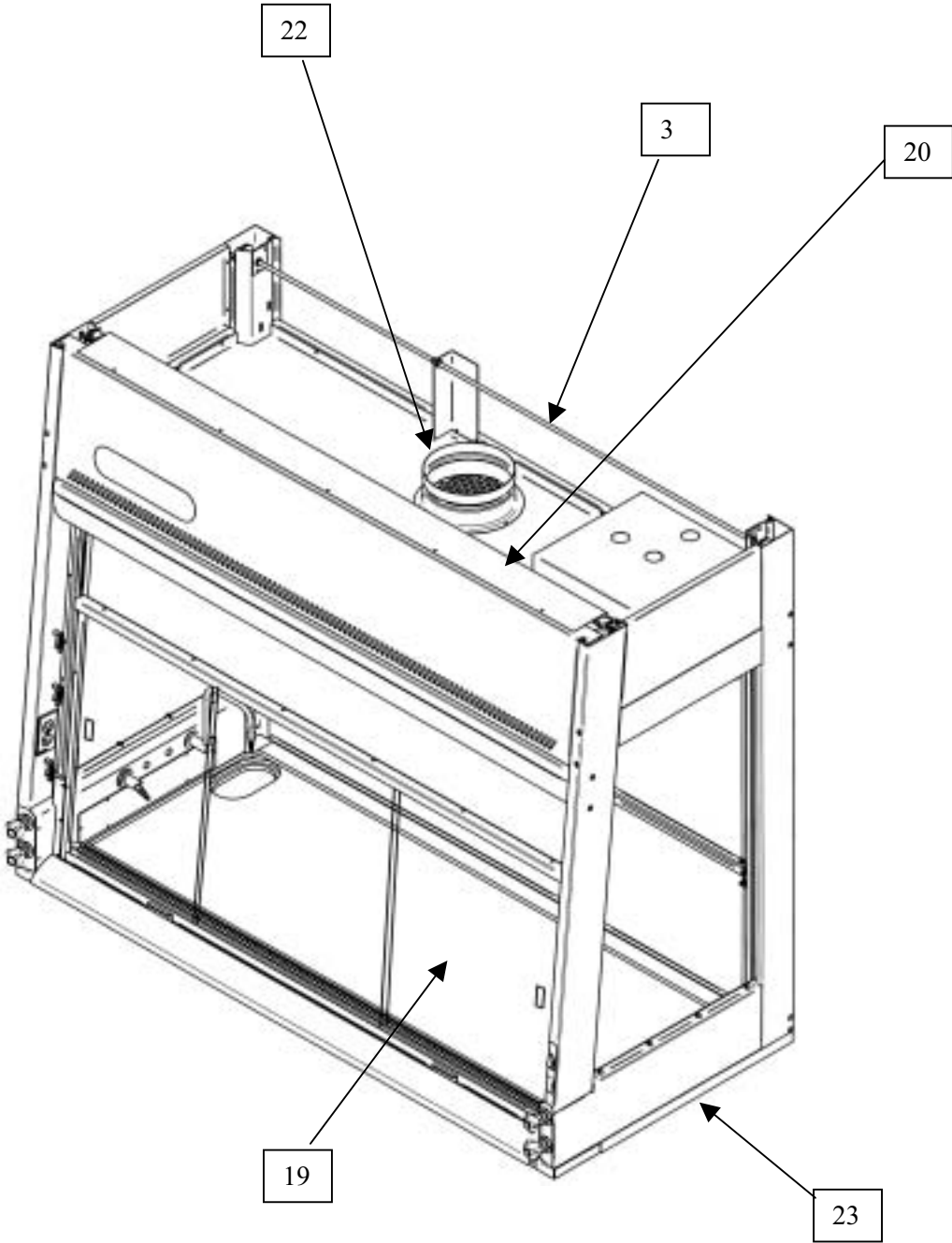

Figure 4-1A



Safety Precautions



Although the laboratory hood has been engineered to maintain optimum operator safety, caution should always be used while working in the hood. Prior to using the hood, check to make sure that the exhaust blower is operating and that air is entering the hood at the proper velocity of 100 fpm.



USE GOOD HOUSEKEEPING IN THE HOOD AT ALL TIMES. CLEAN UP SPILLS IMMEDIATELY. PERIODICALLY CLEAN HOOD INTERIOR, INCLUDING FLUORESCENT LIGHT GLASS PANEL. REPLACE BURNED OUT LIGHT BULBS TO MAINTAIN MAXIMUM ILLUMINATION.

DO NOT OVERLOAD THE WORK SURFACE WITH APPARATUS OR WORK MATERIAL. THE SAFE OPERATION OF THE LABORATORY HOOD IS BASED UPON HAVING PROPER AIRFLOW THROUGH THE STRUCTURE. DO NOT PLACE LARGE, BULKY OBJECTS SUCH AS BLOCK HEATERS, DIRECTLY ON THE HOOD WORK SURFACE. INSTEAD, PLACE THE OBJECT ON A BLOCK UP 2" TO 3" TO ALLOW A FLOW OF AIR UNDER THE OBJECT AND INTO THE LOWER REAR BAFFLE EXHAUST SLOT OF THE HOOD. ENSURE

BLOCKS ARE LEVEL AND SET IN PLACE.



Blocking the bottom of the baffle at rear of hood will change the airflow pattern in the hood causing turbulence and possible leakage at the face of the hood. (Don't store containers or supplies against baffles, as this will affect airflow through the hood).

Avoid placing head inside hood. Keep hands out of hood as much as possible.

Always work as far back in hood as possible. It is best to keep all chemicals and apparatus 6" inside the front of the hood.

This hood has not been built with explosion proof components. Therefore, use of flammable or explosive materials in quantities above the explosive limit are not recommended. (Consult with Labconco).

Do not work with or store chemicals in this hood without the exhaust system running.

Perchloric acid use in this hood is prohibited.

High level radioisotope materials are prohibited for usage in this hood.



AVOID CROSS DRAFTS AND EXCESSIVE PERSONNEL PASSAGE IN FRONT OF THE HOOD. AIR DISTURBANCES SO

CREATED MAY DRAW FUMES
OUT OF THE HOOD.



The use of heat generating equipment in this hood without the exhaust system operating properly can cause damage to the hood.

The Protector ClassMate Laboratory Hood should be certified by a qualified certification technician before its initial use. The hood should be re-certified whenever it is relocated, serviced or at least annually thereafter.

Ensure that the unit is connected to electrical service in accordance with local and national electrical codes. Failure to do so may create a fire or electrical hazard. Do not remove or service any electrical components without first disconnecting the hood from electrical service.

Proper operation of the fume hood depends largely upon the hood's location and the operator's work habits. Consult the *Prerequisites Chapter 2, Installation Chapter 3, and Using your Hood Chapter 5.*

Your Next Step

After you understand the theory of operation and safety precautions, you are ready to proceed to *Chapter 5: Using Your Protector ClassMate Fume Hood.*



CHAPTER 5

USING YOUR

PROTECTOR

CLASSMATE FUME

HOOD

Operating the Vertical Rising Sash



Because of the Protector ClassMate's counterbalanced, anti-racking sash mechanism, it will take only a few pounds of force to move the sash up or down, and you can operate the sash smoothly with one or two hands positioned any where along the handle. The vertical rising sash may be raised from a closed to 18" operating height where it bumps the sash stop. (See Figure 5-1) For loading and cleaning, the sash moves up past the sash stop; however, please note that the airflow requirements are sized for the 18" operating height.



Figure 5-1

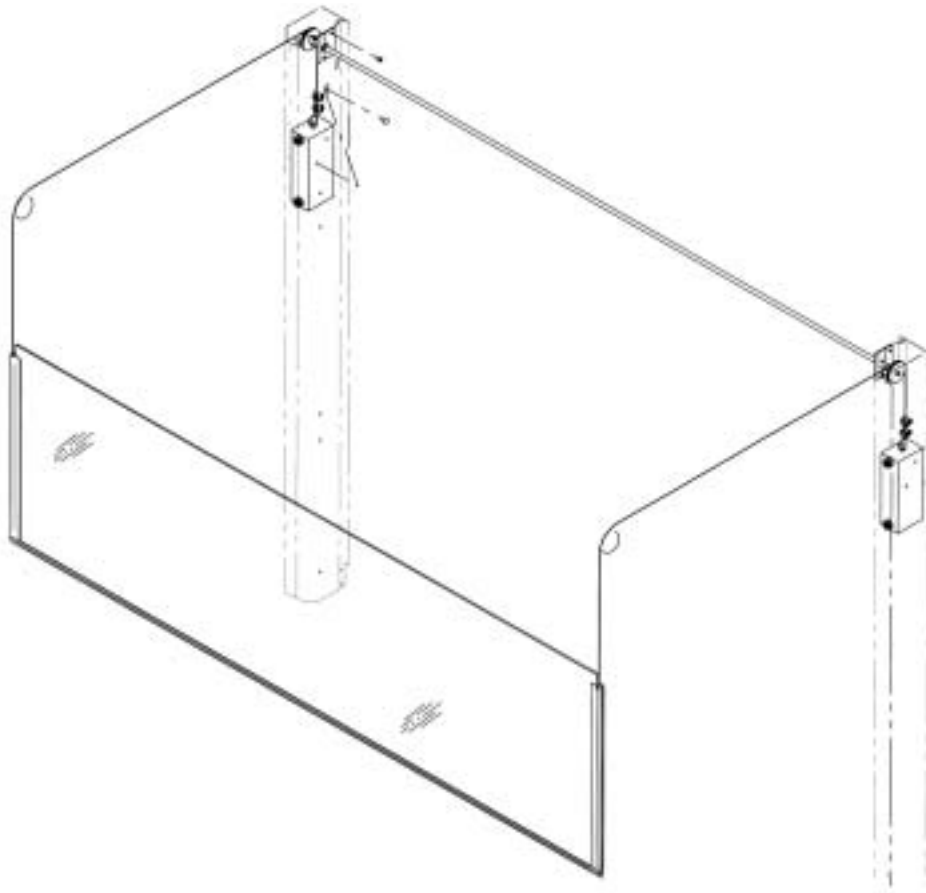

A

Operating the A-Style Combination Sash

Some hood models have additional energy saving sashes called A-Style Combination Sashes in place of vertical-rising and pivoting sashes. These combination sashes allow the operator to use the hood with sashes either half open horizontally or vertically to conserve energy. The horizontal sashes are used in normal operating mode. Two sets of integral sash stops prevent raising the vertical sash above the half-open and fully closed positions unless manually defeated by the operator. The airflow requirements are sized for the 50% open sash condition. (See Figure 5-2)

Figure 5-2

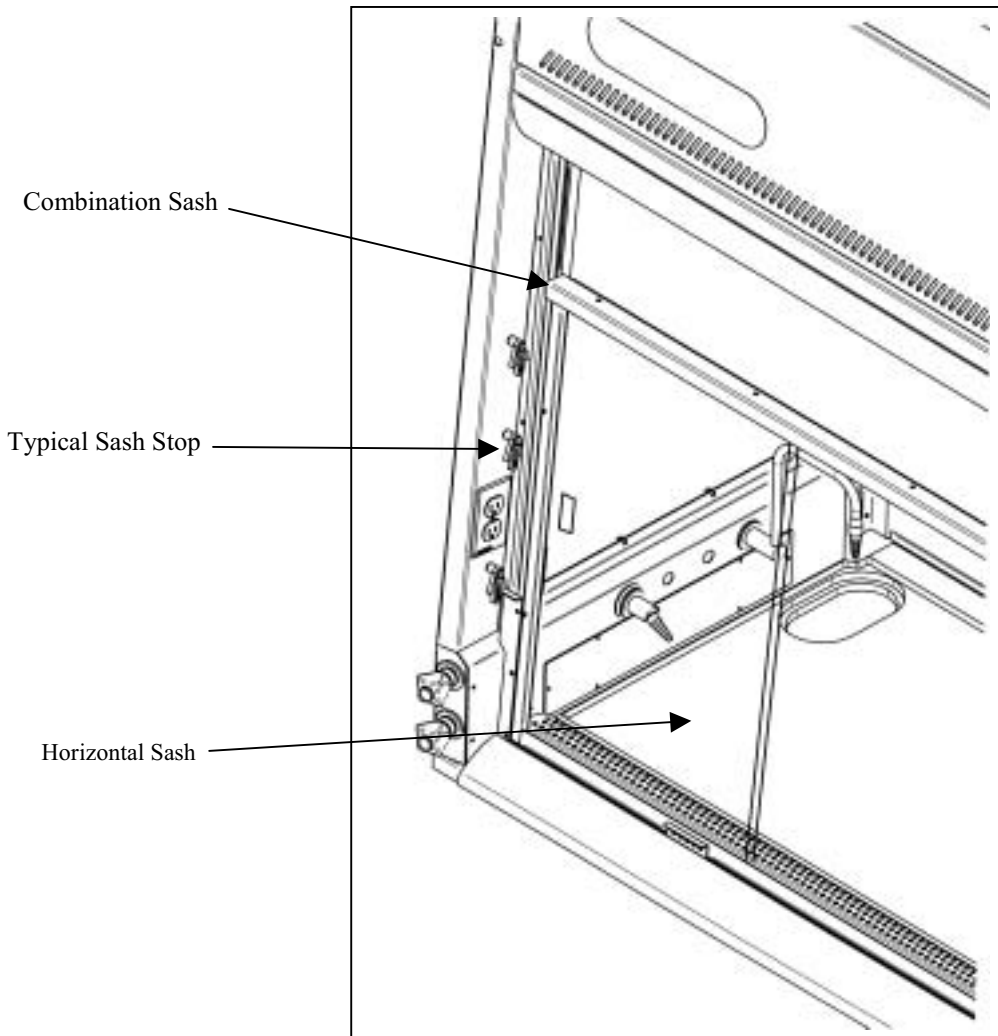

Operating the Blower

Your Protector ClassMate Fume Hood utilizes a remote style blower, which can be activated from the blower switch by turning the blower switch to “ON”. You can validate the hood performance by watching smoke be drawn away from the hood face opening. (See Figure 5-3)

S

A

S **A**

Operating the Lights

Your Protector ClassMate Fume Hood utilizes a factory wired fluorescent light to illuminate the hood interior. Simply turn the light switch to “ON” to operate. (See Figure 5-4)

Figure 5-3

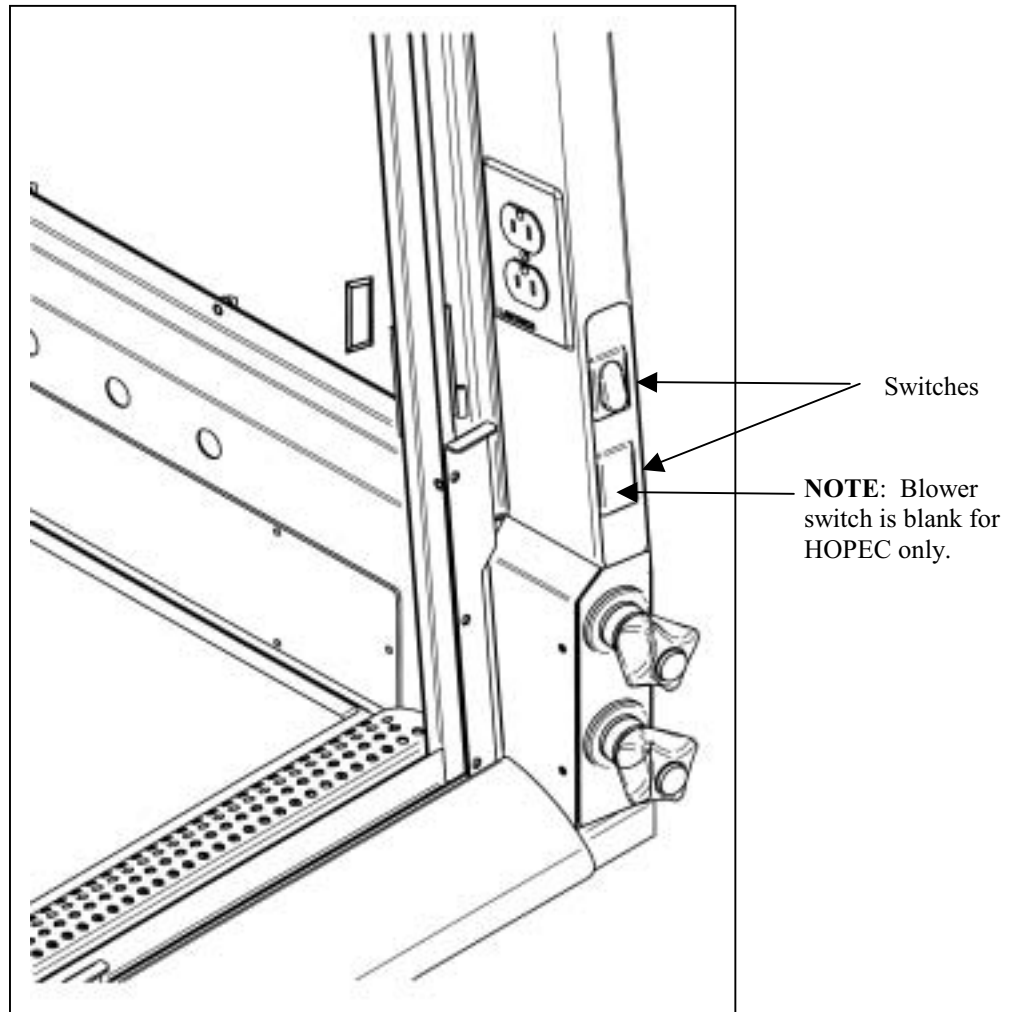

Working in your Protector ClassMate Fume Hood

Planning

- Thoroughly understand procedures and equipment required before beginning work.
- Arrange for minimal disruptions, such as room traffic or entry into the room while the hood is in use.

Start-up

- Turn on fluorescent light and hood blower.
- Slowly raise the sash.
- Check the baffle air slots for obstructions.
- Allow the hood to operate unobstructed for 5 minutes.
- Wear a long sleeved lab coat with knit cuffs and rubber gloves. Use protective eyewear. Wear a protective mask if appropriate.

Wipe-Down

- Raise the sash to its full open position.
- If necessary, wipe down the interior surfaces of the hood with dish soap and glass cleaner and allow to dry.

Loading Materials and Equipment

- Only load the materials required for the procedure. Do not overload the hood.
- Do not obstruct the front airfoil, or rear baffle slots.
- Large objects should not be placed close together.
- After loading the hood, wait one minute to purge airborne contaminants from the work area.

Work Techniques

- Keep all materials at least 6 inches inside of the sash, and perform all contaminated operations as far to the rear of the work area as possible.
- Segregate all clean and contaminated materials in the work area.

- Avoid using techniques or procedures that disrupt the airflow patterns of the hood.

Final Purging

- Upon completion of work, the hood should be allowed to operate for two to three minutes undisturbed, to purge airborne contaminants from the work area.

Unloading Materials and Equipment

- Objects in contact with contaminated material should be surface decontaminated before removal from the hood.
- All open trays or containers should be covered before being removed from the hood.

Wipe-Down

- If dirty, wipe down the interior surfaces of the hood with dish soap and glass cleaner and allow to dry.
- Dispose of rubber gloves appropriately, and have lab coat laundered properly.
- Wash hands and arms thoroughly with germicidal soap.

Shutdown

- Turn off the fluorescent light and hood blower, then close the sash.

Your Next Step

After you understand how to operate and work in the fume hood, you are ready to proceed to *Chapter 6: Maintaining Your Protector ClassMate Fume Hood.*

CHAPTER 6

MAINTAINING YOUR

PROTECTOR

CLASSMATE FUME

HOOD

Now that you have an understanding of how to work in the fume hood, we will review the suggested maintenance schedule and the common service operations necessary to maintain your fume hood for peak performance.



Only trained and experienced certification technicians should perform some of the service operations after the fume hood has been properly decontaminated. DO NOT attempt to perform these operations if you are not properly trained. The wrench icon precedes the service operations that require qualified certifiers.

Routine Maintenance Schedule

Weekly

- Using ordinary dish soap to clean the surface inside of the fume hood, and the work surface.
- Using an appropriate glass cleaner, clean the sash and all glass surfaces.
- Operate the fume hood blower, noting the airflow velocity through the hood using a source of visible smoke.

Monthly (or more often as required)



- Determine the actual face velocity through the sash opening of the hood where the average reading should be 100 feet per minute.
- Using a damp cloth, clean the exterior surfaces of the hood, particularly the front of the hood, to remove any accumulated dust.
- Check all service valves, if so equipped, for proper operation.
- The hood baffles should be checked for blockages behind them to ensure that the hood is maintaining proper airflow.
- All weekly activities.

Annually



- Replace the fluorescent lamps.
- Have the fume hood recertified by a qualified certification technician. See *Certifying the Protector ClassMate Fume Hood in Chapter 3*.
- All monthly activities.

Biannually

- The sash assembly should be checked to ensure proper operation and to make sure there are no signs of abnormal wear on the sash pulleys, cables and clamps.

Service Operations

Front Panel Removal:

1. Simply lift the front panel up and then away from the hood to provide access to the top.

Figure 6-1

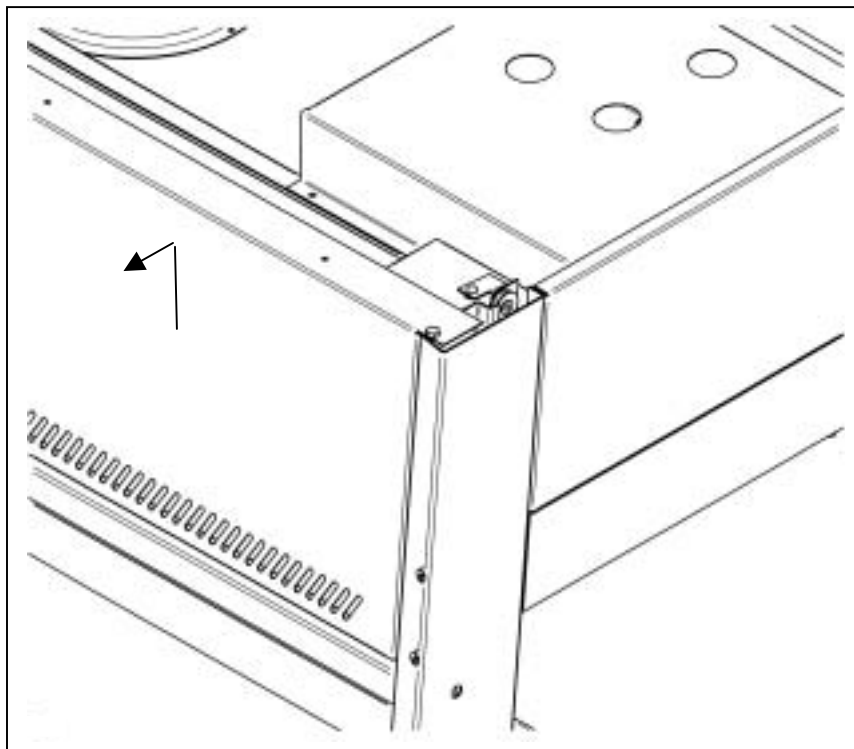

Changing the Fluorescent Lamp:

4'

5'

6'

1. Turn light switch to “OFF”.
2. Remove the front panel as noted earlier.
3. Reach over the front header of the hood and loosen screws to the light reflector and remove light reflector.
4. Remove the fluorescent lamp by pushing it out of the spring-loaded lamp socket and swinging it out of the other lamp socket.
5. Install the new lamp by reversing the removal procedure.

Figure 6-2

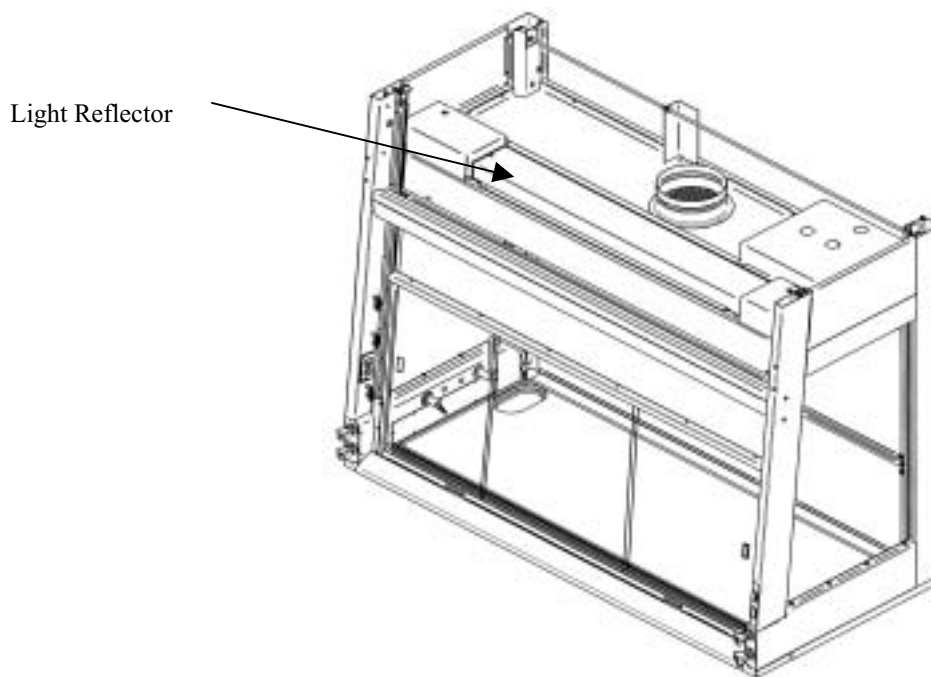

Your Next Step

After you understand the maintenance procedures, you are ready to proceed to *Chapter 7: Modifying Your Protector ClassMate Fume Hood.*

CHAPTER 7

MODIFYING YOUR

PROTECTOR

CLASSMATE FUME

HOOD

There are several ways to modify the fume hood for your individual requirements. These include the addition of service fixtures, exhaust adapter, air monitor, distillation grids, and electrical duplex outlets. See *Appendix D: Protector ClassMate Accessories* to order.

Installing Additional Service Fixtures

Additional service fixtures can be installed in the four available service fixture holes in both side walls. However, the Protector ClassMate Fume Hood can only mount two valves per side on the hood; the other two valves, per side, must be mounted on the support cabinet below.





If the service line pressure exceeds 40 PSI, it must be equipped with a pressure regulator to reduce the line pressure. Please use the appropriate instructions for the appropriate valves. See *Appendix D: Protector ClassMate Accessories* to order.

Labconco Service Fixture

1. Decide the locations (either position 1 or 3) you want to install the service fixture and outlet fitting and remove the hole plugs, and access panels. (See Figure 7-1)
2. Mount the Labconco Valve (P/N 9817000) through the hole and tighten with the supplied nut (P/N 9818000). Mount the knob (P/N 98187-XX, lens (P/N 9818900), and label (P/N 9825500) underneath the lens. XX colors as follows:
 - 00 Argon - Gray
 - 01 CW - Green
 - 02 GAS - Blue
 - 03 AIR - Orange
 - 04 VAC - Yellow
 - 05 HW - Red
 - 06 DW - White
 - 07 STM - Black
 - 08 NIT - Brown
3. Mount the Bulkhead Union (P/N 1449500) on the sidewall through the 3/4" diameter hole and tighten the supplied nut (P/N 9819001) with a 7/16" lockwasher (P/N 1910819).
4. Connect one end of the Outlet Service Tube (Part numbers listed next), to the Bulkhead Union Tube fitting by pressing the tube all the way into the fitting, and through the two ferrules turning the tubing nut hand tight, and then approximately one more turn using pliers or a 9/16" wrench.
5. Connect the other end of the Outlet Service Tube (Part numbers listed next) to the Labconco Valve fitting by pressing the tube all the way into the fitting and through the two ferrules turning the tubing nut hand tight, and then approximately one

more turn using pliers or a 9/16" wrench. Note the flow direction on the valve.

Following is a list of Labconco Outlet Service Tube Part Numbers:

Part Number	Location	Position
69945-00	Front Right	1
69945-01	Front Left	1
69945-02	Front Right (Gas)	1
69945-03	Front Left (Gas)	1
69946-00	Rear Right	3
69946-01	Rear Left	3
69946-02	Rear Right (Gas)	3
69946-03	Rear Left (Gas)	3
69846-00	Rear Gooseneck Only	3

6. Connect the Supply Service Tube between the source and the Labconco Valve fitting by pressing the tube all the way into the fitting and through the two ferrules turning the tubing nut hand tight, and then approximately one more turn using pliers or a 9/16" wrench. (Order P/N 4889900 or 4921100 (Gas) for 5.5' of supply tubing)
7. Apply Teflon® Tape P/N 1485700 to the Bulkhead Fitting and tighten the appropriate colored Plastic Hose Connector P/N 98188-XX with a wrench.
8. Make sure the valve service fitting is turned off before pressurizing the service line. Once pressurized, check the valve body, connectors, and fittings for leaks. Tighten any leaking joints.

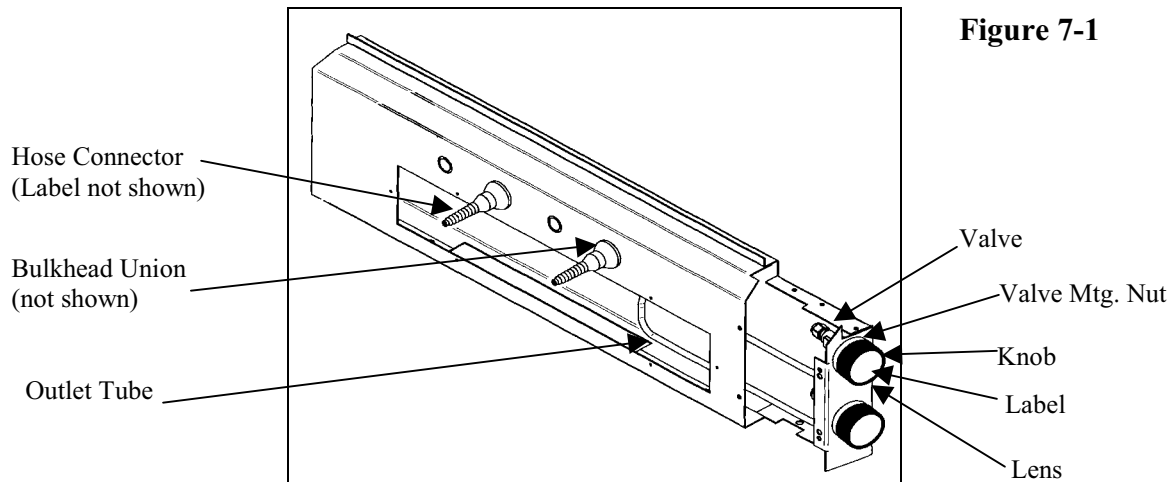

Figure 7-1

Labconco Service Fixture with Gooseneck

Use the instructions above for the Labconco Service Fixture except Steps 3 and 4 use the following:

- 3a. (Gooseneck only) Mount the gooseneck outlet fitting P/N 6983705 on the sidewall through the 3/4" diameter hole and tighten the supplied nut and washer.
- 3b. (Gooseneck only) Mount the 3/8" female and 3/8" male street elbow P/N 1402400 to the gooseneck outlet fitting. Apply pipe sealant P/N 1577900 to the threads. Tighten the fitting with a wrench or pliers.
- 3c. (Gooseneck only) Mount the 3/8" pipe x 1/4" tube female connector P/N 4890300 to the street elbow. Apply pipe sealant P/N 1577900 to the threads. Tighten the fitting with a wrench or pliers.
4. (Gooseneck only) Connect one end of the outlet service tube P/N 6984600 to the gooseneck female connector fitting (from Step 4c) by pressing the tube all the way into the fitting and through the two ferrules, turning the tubing nut hand tight, and then approximately one more turn using pliers or a 9/16" wrench.

WaterSaver Service Fixture and/or Gooseneck

1. Decide into which of the available locations (positions either 1 or 3) you want to install the service fixture and outlet fitting and then remove the hole plugs, valve cover, plates, and access panels. (See Figure 7-2)

2. Mount the WaterSaver valve, listed below, through the 1.25" diameter hole and tighten the supplied round locking ring.

Part Number	Description
69837-00	WaterSaver rigid gooseneck and valve
69837-01	WaterSaver (VAC) Connector and valve
69837-02	WaterSaver (AIR) Connector and valve
69837-03	WaterSaver (GAS) Connector and valve
69837-04	WaterSaver Swivel Gooseneck and valve

3. Mount two each 3/8" pipe x 1/4" tube male connectors P/N 1410701 to the WaterSaver valve with pipe sealant P/N 1577900 and tighten the male connectors approximately one turn past hand tight.
4. Mount the WaterSaver outlet connector or gooseneck on the sidewall through the 3/4" diameter hole and tighten the supplied nut and washer.
5. Mount the 3/8" female x 3/8" male street elbow P/N 1402400 to the outlet fitting. Apply pipe sealant P/N 1577900 to the threads. Tighten the fitting with a wrench or pliers.
6. Mount the 3/8" pipe x 1/4" tube female connector P/N 4890300 to the street elbow. Apply pipe sealant P/N 1577900 to the threads. Tighten the fitting with a wrench or pliers.
7. Connect one end of the outlet service tube, part numbers listed below, to the female connector fitting, from Step 5, by pressing the tube all the way into the fitting, and through the two ferrules, turning the tubing nut hand tight, and then approximately one more turn using a 9/16" wrench.
8. Connect the other end of the outlet service tube, part number listed below, to the WaterSaver valve male connector fitting by pressing the tube all the way into the fitting and through the two ferrules, turning the tubing nut hand tight, and then approximately one more turn using 9/16" wrench. Note the flow direction on the valve.

Watersaver Outlet Service Tube Part Numbers

Part Number	Location	Position
6991300	Front	1
6991301	Front (Gas)	1
6991400	Rear	3
6991401	Rear (Gas)	3
6991400	Rear Gooseneck Only	3

9. Connect the supply service tube between the source and the WaterSaver valve male connector fitting by pressing the tube all the way into the fitting and through the two ferrules, turning the tubing nut hand tight, and then approximately one more turn using a 9/16" wrench. (Order P/N 4889900 or 4921100 (Gas) for 5.5' of supply tubing).
10. Make sure the valve service fitting is turned off before pressurizing the service line. Once pressurized, check the valve body, connectors, and fittings for leaks. Tighten any leaking joints.

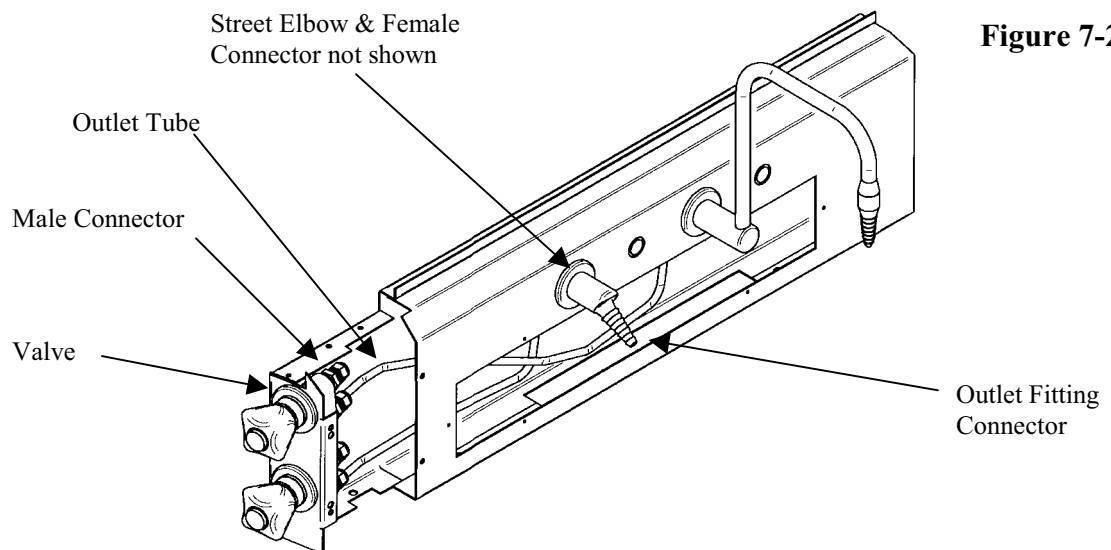
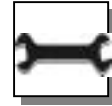

Figure 7-2

Installing Exhaust Adapter for Back to Back Hoods

The common exhaust adapter P/N 6987000 allows you to duct two back-to-back Protector ClassMate Fume Hoods from two 8" (8.62" O.D. pipe) exhaust stacks to one 12" (12.00" O.D. pipe) exhaust stack. (See Figure 7-3)



Step 1. Simply place the adapter on both hood exhausts and seal with silicone sealant.

Step 2. Attach the 12" (12.00" O.D.) pipe to your blower exhaust.

Figure 7-3

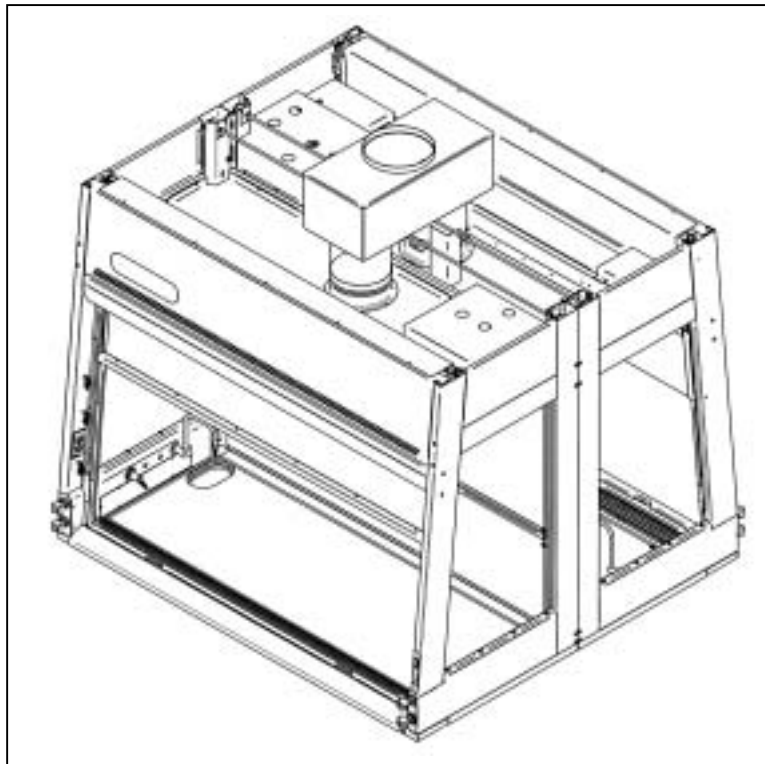

Installing Guardian Digital Airflow Monitor

The Digital Airflow Monitor P/N 97432-03 allows you to continuously monitor face velocity through the fume hood opening. (See Figure 7-4, Figure 7-5, and Figure 7-6)

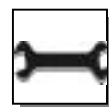

Tools Required:

1. Power Drill
2. Drill bit size #37 (0.104")
3. 33/64" diameter hole saw
4. Reciprocating saw with saw blades for cutting sheet metal
5. Pilot drill sized to fit the saw blade
6. Phillips head screwdriver with #1 point
7. Slotted screwdriver with 3/32 blade width



DANGER: Always wear eye protection when using power tools. Observe all necessary precautions when installing or repairing monitors near electrical equipment.

Figure 7-4

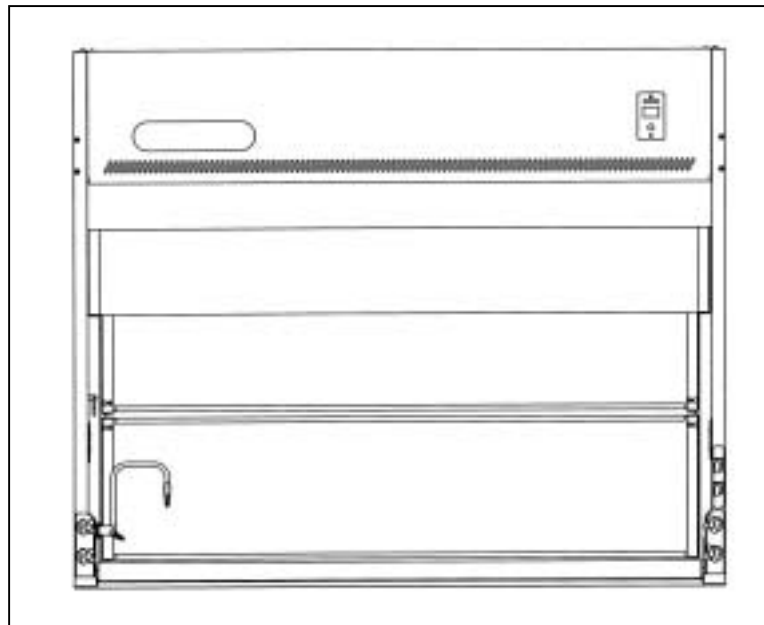

Procedure:

Step 1: The mounting location of the monitor shall be 3" down from the top and 7" from the right side to the centerline located on the front panel. Use the cardboard template supplied as a guide for the size of the installed product and the hole needed to be cut out of the hood. The cutout required is 3" high by 2" wide, which is the

typical size required for a single switch electrical box. If the cardboard template is not available, a dimensioned pictorial is at the back of the manual included with the monitor.

- Step 2: Using the template, mark off the 3" high by 2" wide hole necessary to clear the rear enclosure portion of the monitor. Mark off the two mounting screw hole locations.
- Step 3: Drill a pilot hole in each of the four corners. Use the saw to cut out the hole. A suitable nibbling tool may also be used.
- Step 4: Drill the two #37 mounting screw holes.
- Step 5: Screw the monitor to the fume hood front panel.
- Step 6: Remove the 0.50" diameter hole plug located on the front of the upper top shelf to the right of the fluorescent lights. Install the .50" diameter x 9.00" long tube P/N 6985100 in the hole. The .50" diameter tube shall extend into the interior fume hood cavity 7.50" with 1.50" above the top shelf. Secure the tube with silicone sealant P/N 1579100.
- Step 7: Turn the blower and light switches to OFF. Connect the input/output signal wiring, if required, to the terminal block on the back of the monitor. See the Electrical Wiring *Appendix C* section for wiring information.

Figure 7-5

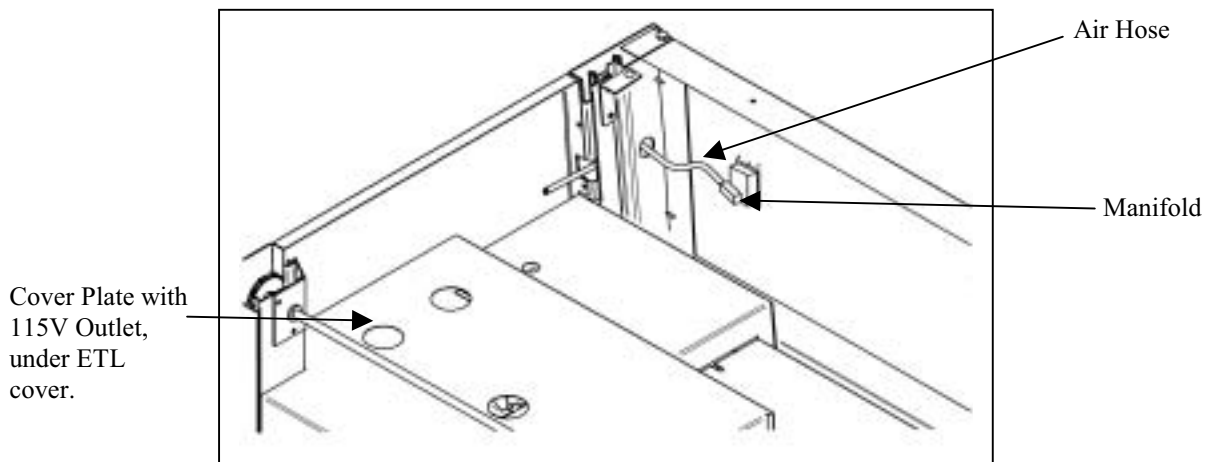

- Step 8: Place the right angle manifold P/N 6977000 on the back of the monitor so that the exit from the manifold faces the open slot on the right side vertical support of the fume hood. Secure the manifold to the monitor with silicone sealant P/N 1579100. (See Figure 7-5)
- Step 9: With the manifold exit facing the open slot insert the .50" diameter barbed hose stem P/N 1548101 into the manifold and secure with silicone sealant P/N 1579100.
- Step 10: Connect one end of the supplied air hose to the .50" diameter tube at the 1.50" extension. Route the hose as necessary to prevent kinks and bends which can affect the calibration. Route through open slot. Trim slightly if required. Firmly connect the other end to the stem on the rear of the monitor. Air hose is now complete.
- Step 11: Connect the 9VDC power cord to the power jack on the monitor.
- Step 12: Replace the junction box cover plate with the new junction box cover plate P/N 6985000 that has a .968" square cutout for the outlet assembly. Snap-in the 115V outlet assembly P/N 7907802 into the .968" square cutout. (See Figure 7-6)
- Step 13: Connect the male terminals from the 115V outlet assembly to the female terminals, which are part of the hood wiring harness. Refer to the Wiring Diagram in Appendix C and you will see black to 1C-black and white to 6-red and green to ground. Power is now supplied to the 115V outlet.
- Step 14: Attach the junction box cover plate with the 115V outlet to the junction box. Plug the 9VDC power supply into the wired 115V outlet. Power is now supplied to the monitor

when the blower and light switches are turned “ON”. (See Figure 7-6)

Step 15: The installation of the monitor is now complete.

Step 16: Refer to the air monitor manual for calibration, programming, and set-up.

Figure 7-6

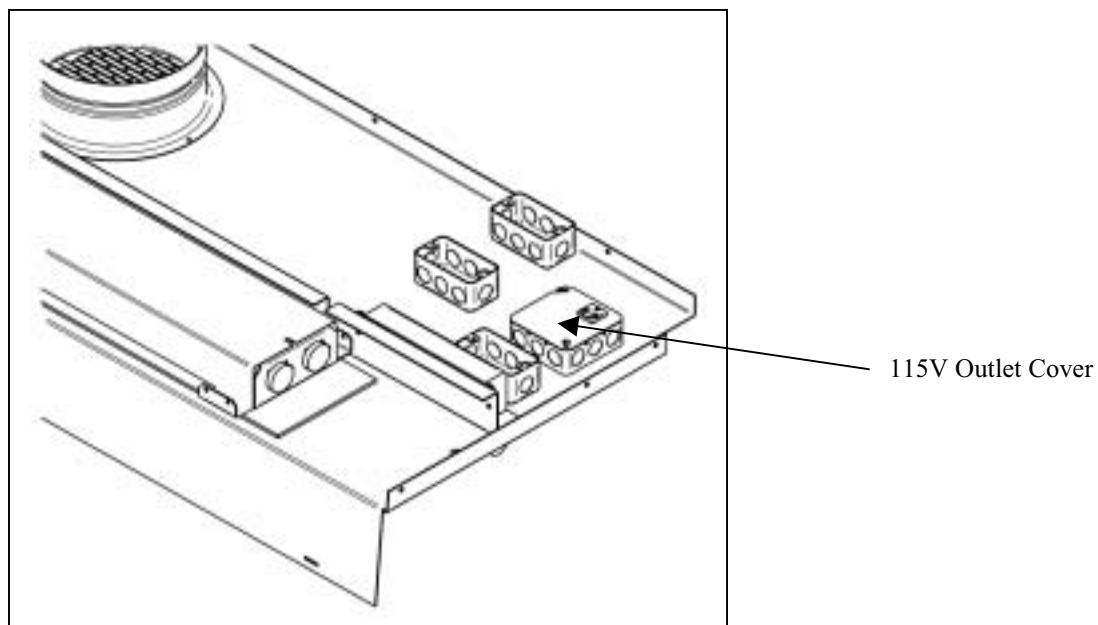

Distillation Grids – Field Installation

Location – Standard Mounting

The distillation grids P/N’s 6973300, 6973301, and 6973302 have been strategically placed with the vertical rod center lines at a distance of 4" in front of the lower baffle and middle baffle. The distillation grids allow the hood user to mount motors, stirrers, and other apparatus.



	Description	Model No.
4'	Hood Distillation Grid Kit	6973300
5'	Hood Distillation Grid Kit	6973301
6'	Hood Distillation Grid Kit	6973302

Figure 7-7

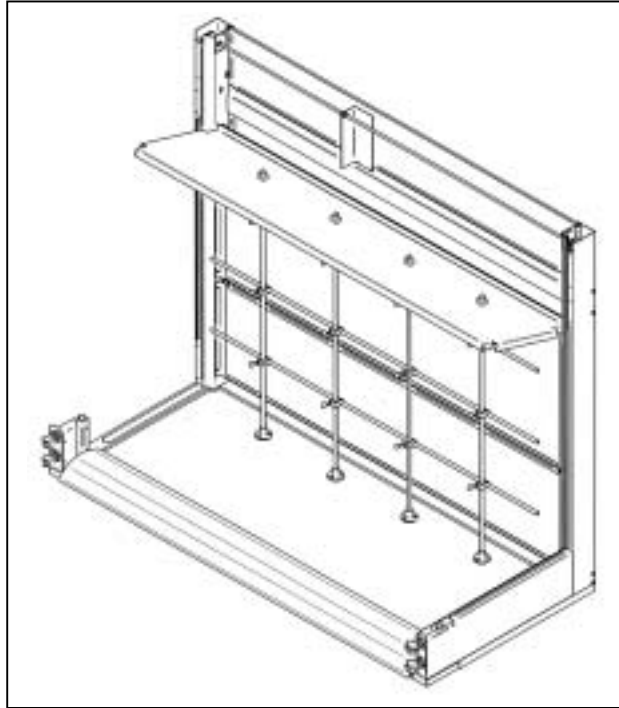
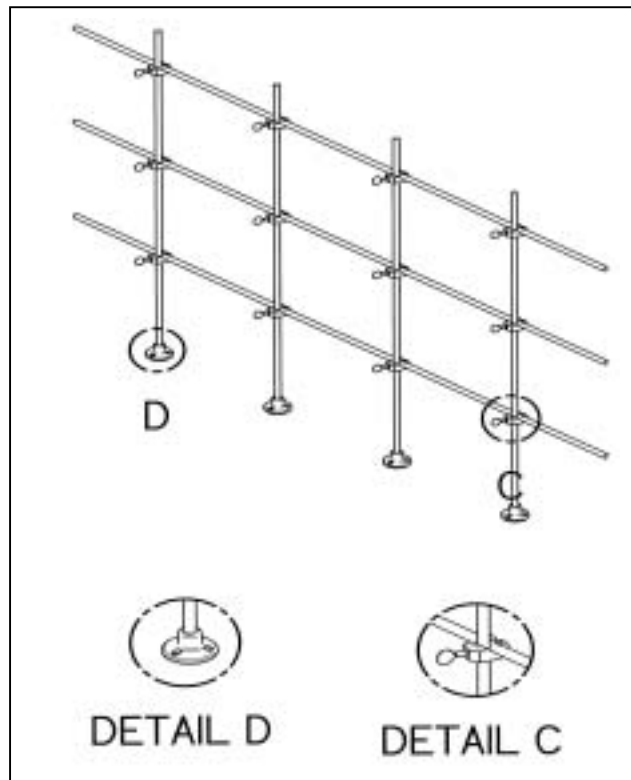

Figure 7-8



1. Remove the hole plugs and install the grommets into the upper baffle.
2. The vertical rods can now be systematically installed in front of the horizontal rods. The bottom of the rods slip into the footplates which rest on the work surface. Tighten the clamping screws on the footplates. For support you need to drill .147 diameter pilot holes and mount the footplates that rest on the work surface. Use the additional #8 thread forming screws in the kit to mount the footplates to the work surface. Another alternative is to secure the footplates to the work surface with clear RTV sealant.
3. Install all the hook connectors, which connect all the vertical rods to the horizontal rods, then install the horizontal rods. Please note that all the vertical rods are in **front** of the horizontal rods. Simply tighten all the thumbscrews on the hook connectors.
4. The installation is now complete and is ready to mount your apparatus.

Installing a 115V Electrical Duplex Outlet



Your Protector ClassMate Fume Hood can be ordered with duplex outlets, however, if you ordered a model without a 115V electrical duplex outlet you can have one installed in the field by a qualified electrician.

Figure 7-9

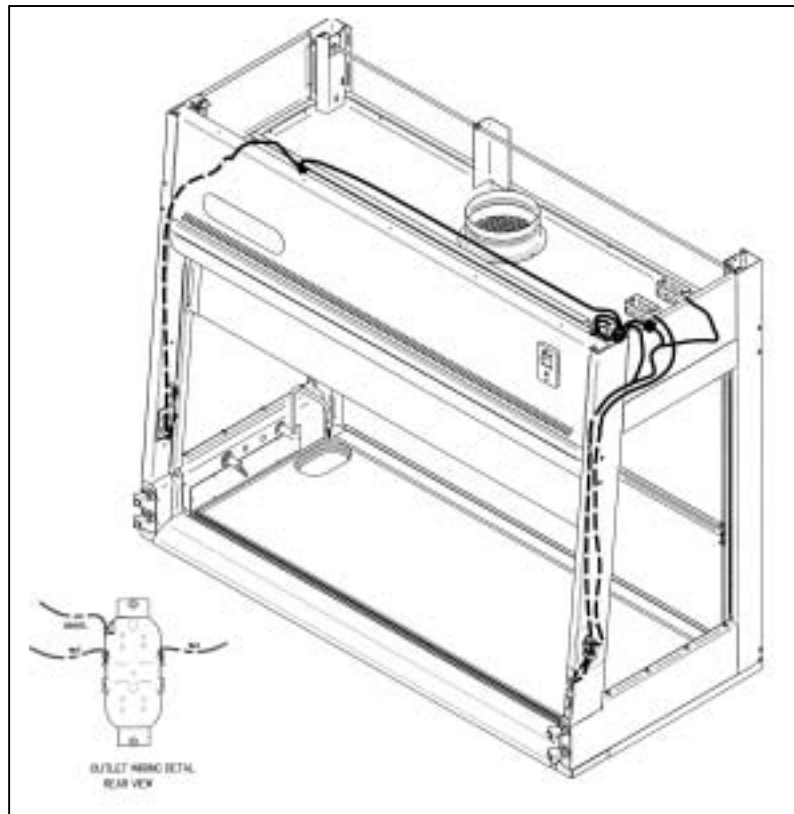

Order the following parts from Labconco to field install a 115V electrical duplex outlet assembly.

Parts Required:

Qty	Part No.	Description
1 ea.	6982400	Outlet Harness 115V, 15A
1 ea.	1885608	Screw, #6-32 x .50 Type F oval head black
1 ea.	1230700	Receptacle, Duplex 115V, 15A Gray
1 ea.	4922401	Wallplate, Duplex Receptacle Gray
2 ea.	1220300	Cable Connector

- Step 1: Remove the gray blank wall plate from the hood corner. It is attached to the hood with silicone sealant. You will probably damage the blank wall plate upon removal.
- Step 2: Remove the 2 x 4 handy box cover on the top of the fume hood from the nearest junction box to the front.
- Step 3: Install the cable connectors on the junction box, one for inlet power, and one for outlet power.
- Step 4: Route power from the junction box to the front corner post using the outlet harness. Route cable through the slot in the corner post.
- Step 5: Wire outlet cable to 115V duplex receptacle and attach receptacle to front corner post with two #6-32 supplied screws.
- Step 6: Attach gray duplex receptacle wall plate to the duplex using the #6-32 black oval head screw.
- Step 7: Wire 115V, 15A supply line to the outlet harness. Be sure the line is properly grounded to the junction box.
- Step 8: Circuit test 115V electrical duplex outlet.
- Step 9: Replace the 2 x 4 handy box cover when testing is complete.

Your Next Step

After you understand the modifying procedures, you are ready to proceed to *Chapter 8: Troubleshooting*.

CHAPTER 8

TROUBLESHOOTING

Refer to the following table if your fume hood fails to operate properly. If the suggested corrective actions do not solve your problem, contact Labconco for additional assistance.

PROBLEM	CAUSE	CORRECTIVE ACTION
Remote blower and lights won't turn on	Wires not connected at junction boxes or switches.	Check connection of switches. Check connection to control box on top of unit.
	Circuit breakers tripped in building electrical supply.	Reset circuit breakers.
	Remote Blower won't turn on but lights work	Blower wiring is disconnected. Blower motor is defective.
Fume Hood blower turns on but lights don't work	Lamp not installed correctly.	Inspect lamp installation.
	Lamp is defective.	Replace lamp.
	Lamp circuit breaker in building is tripped.	Reset the lamp circuit breaker.

PROBLEM	CAUSE	CORRECTIVE ACTION
Fume Hood blower turns on but lights don't work (cont.)	Lamp wiring is disconnected.	Inspect lamp wiring.
	Defective lamp ballasts.	Replace lamp ballasts.
Contamination outside of laboratory fume hood	Improper technique or procedure for the fume hood.	See "Certifying the Hood Chapter 3 and "Safety Precautions" Chapter 4 sections in the manual.
	Restriction of the baffle air slots or – blockage of the exhaust outlet.	Ensure that all baffle air slots, and the exhaust outlet are unobstructed.
	External factors are disrupting the fume hood airflow patterns or acting as a source of contamination.	See "Location Requirements" Chapter 2, "Certifying the Hood" Chapter 3, and "Safety Precaution" Chapter 4 sections of this manual.
	Fume Hood has improper face velocity of 100 fpm average.	Have fume hood re-certified and check remote blower exhaust system.
Fume Hood Vertical Sash no longer operates smoothly	Cable is frayed or plastic protection is damaged.	Inspect cable and replace cable if worn or damaged; otherwise injury could result.
	Pulley bearing is damaged.	Replace pulley, bearing or add grease.
	Cable has slipped off the pulleys.	Re-install cable or replace if damaged.
	Weight has broken pulleys.	Replace weight pulleys.
Fume Hood combination A-Style Sash no longer operates smoothly	Horizontal glass panels have come off the tracks.	Re-install horizontal glass on tracks.

PROBLEM	CAUSE	CORRECTIVE ACTION
	Vertical sash frame is crooked.	Place horizontal glass symmetrically and pull sash down to airfoil to re-align.
	Cable is frayed or has slipped off the pulleys.	Re-install cable or replace if damaged.
Electrical duplex outlets no longer have power	Wires not connected or faulty duplex.	Check wire connection or replace duplex.
	Circuit breakers tripped in building electrical supply.	Reset circuit breakers.
Service valves no longer operate	Faulty building supply.	Inspect building supply and appropriate pressures below 40 PSI.
	Valve no longer operates.	Replace valve and check for leaks.
	Supply line or outlet line has leaks.	Inspect line for leaks and fix any leaking plumbing connections.

APPENDIX A

PROTECTOR

CLASSMATE

COMPONENTS

Illustrations A-1 and A-2 indicate the location of the following service parts:

Protector ClassMate Replacement Parts

Item	Quantity	Part No.	Description
1A	1	9817000	Labconco Valve
1B	1	9817000	Labconco Valve (Gas)
2A	1	6983700	WaterSaver Rigid Gooseneck and Valve
2B	1	6983701	WaterSaver (VAC) Connector and Valve
2C	1	6983702	WaterSaver (AIR) Connector and Valve
2D	1	6983703	WaterSaver (GAS) Connector and Valve
2E	1	6983704	WaterSaver Swivel Gooseneck and Valve
2F	1	6983705	WaterSaver Swivel Gooseneck Only
3A	1	9818700	Knob (Argon - Gray)
3B	1	9818701	Knob (CW - Green)
3C	1	9818702	Knob (GAS - Blue)
3D	1	9818703	Knob (AIR - Orange)
3E	1	9818704	Knob (VAC - Yellow)
3F	1	9818705	Knob (HW - Red)
3G	1	9818706	Knob (DW - White)
3H	1	9818707	Knob (STM - Black)
3I	1	9818708	Knob (NIT - Brown)
3J	1	9818900	Lens
4A	1	9818800	Hose Connector (Gray) Standard Argon
4B	1	9818801	Hose Connector (Green) Cold Water
4C	1	9818802	Hose Connector (Blue) Gas
4D	1	9818803	Hose Connector (Orange) Air
4E	1	9818804	Hose Connector (Yellow) VAC
4F	1	9818805	Hose Connector (Red) Hot Water
4G	1	9818806	Hose Connector (White) Deionized Water
4H	1	9818807	Hose Connector (Black) Steam

Appendix A: Protector ClassMate Components

Item	Quantity	Part No.	Description
4I	1	9818808	Hose Connector (Brown) Nitrogen
5	1	9825500	Label, Knob
6	1	1302300	Switch, Rocker
7A	1	1230700	115V Duplex Receptacle (Gray)
7B	1	4922401	Duplex Cover Plate (Gray)
8A	1	1277900	Lamp, Fluorescent 3' (use on 4' Hood)
8B	1	1270500	Lamp, Fluorescent 4' (use on 5', 6' Hoods)
9A	1	3704700	Ballast Assy, 3' Bulbs (use on 4' Hood)
9B	1	3704701	Ballast Assy, 4' Bulbs (use on 5', 6' Hoods)
10A	1	6991100	Valve Cover Plate, Left
10B	1	6991101	Valve Cover Plate, Right
10C	1	6992400	Valve Cover Plate, HOPEC Left
10D	1	6992401	Valve Cover Plate, HOPEC Right
11	1	6988400	Access Panel
12A	1	6989300	Side Panel L.H.
12B	1	6989301	Side Panel R.H.
13A	1	6991900	Air Foil Std. 4'
13B	1	6991901	Air Foil Std. 5'
13C	1	6991902	Air Foil Std. 6'
13D	1	6991903	Air Foil, A-Style 4'
13E	1	6990201	Air Foil, A-Style 5'
13F	1	6990202	Air Foil, A-Style 6'
14A	1	6990600	Trough 4'
14B	1	6990601	Trough 5'
14C	1	6990602	Trough 6'
15	2	1924300	Screw, Shoulder #10-24/ .25 x .25
16	1	1885405	Screw, #6-32 x .31 Stainless
17	2	1861400	Pulley, Front
18	1	1489100	Lubriplate Grease
19	2	6982700	Sheave, Rear
20	2	1934400	Bearing, Flanged Rear
21	2	4949902	Cable, Sash 130"
22	4	1920100	Clamp, Cable
23A	4	9709400	Roller, Combination A-Style Sash
23B	4	9709600	Spacer, Combination A-Style Sash
23C	4	9709100	Washer, Roller Retainer
23D	4	1910908	#8 Lockwasher Inter Star SS
23E	4	1894606	Screw Machine #8-32 x .38 SS with Nylon Lock
24A	1	6973100	Sash Assy., Combo A-Style 5'
24B	1	6973101	Sash Assy., Combo A-Style 6'

Figure A-1

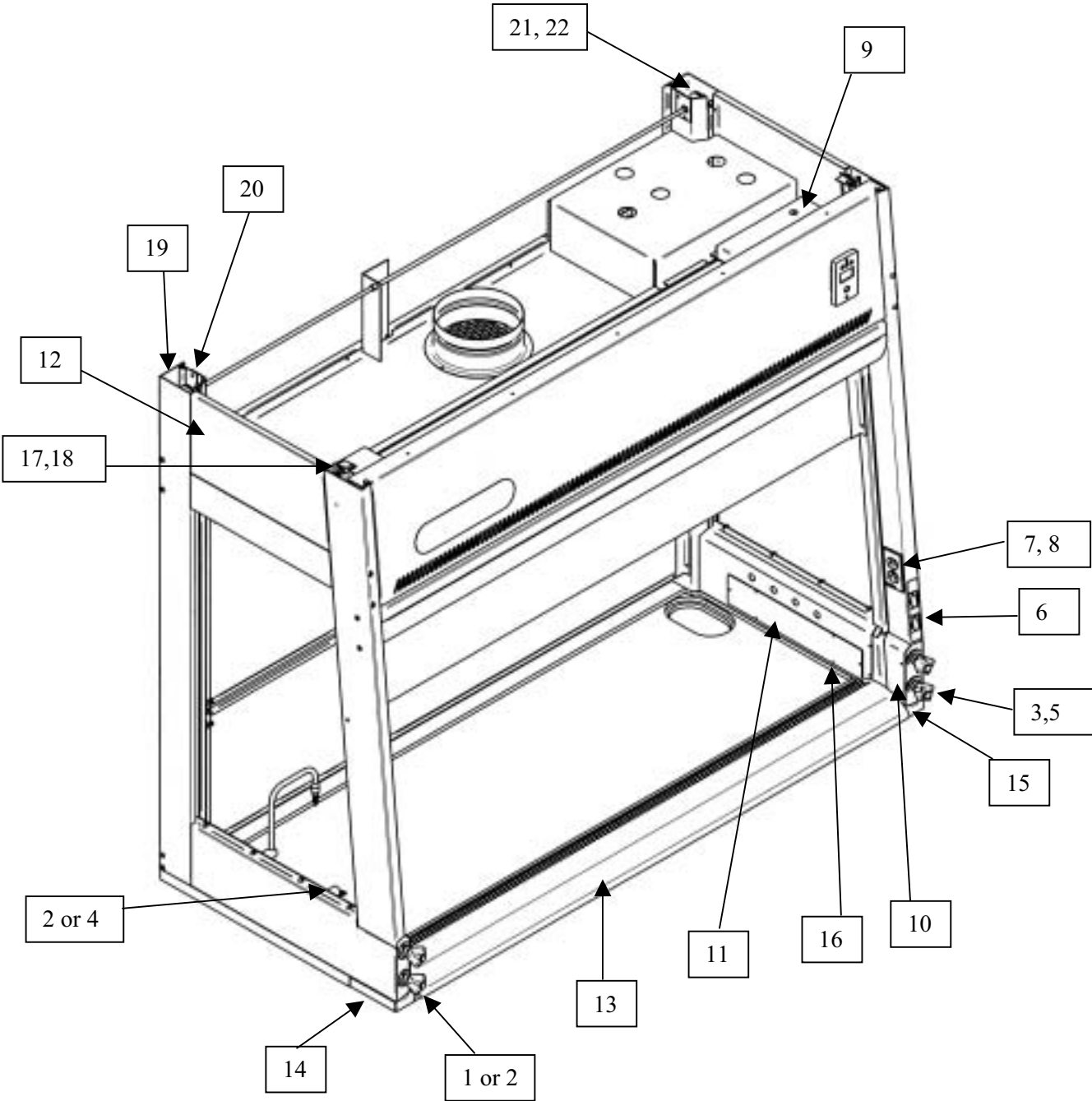
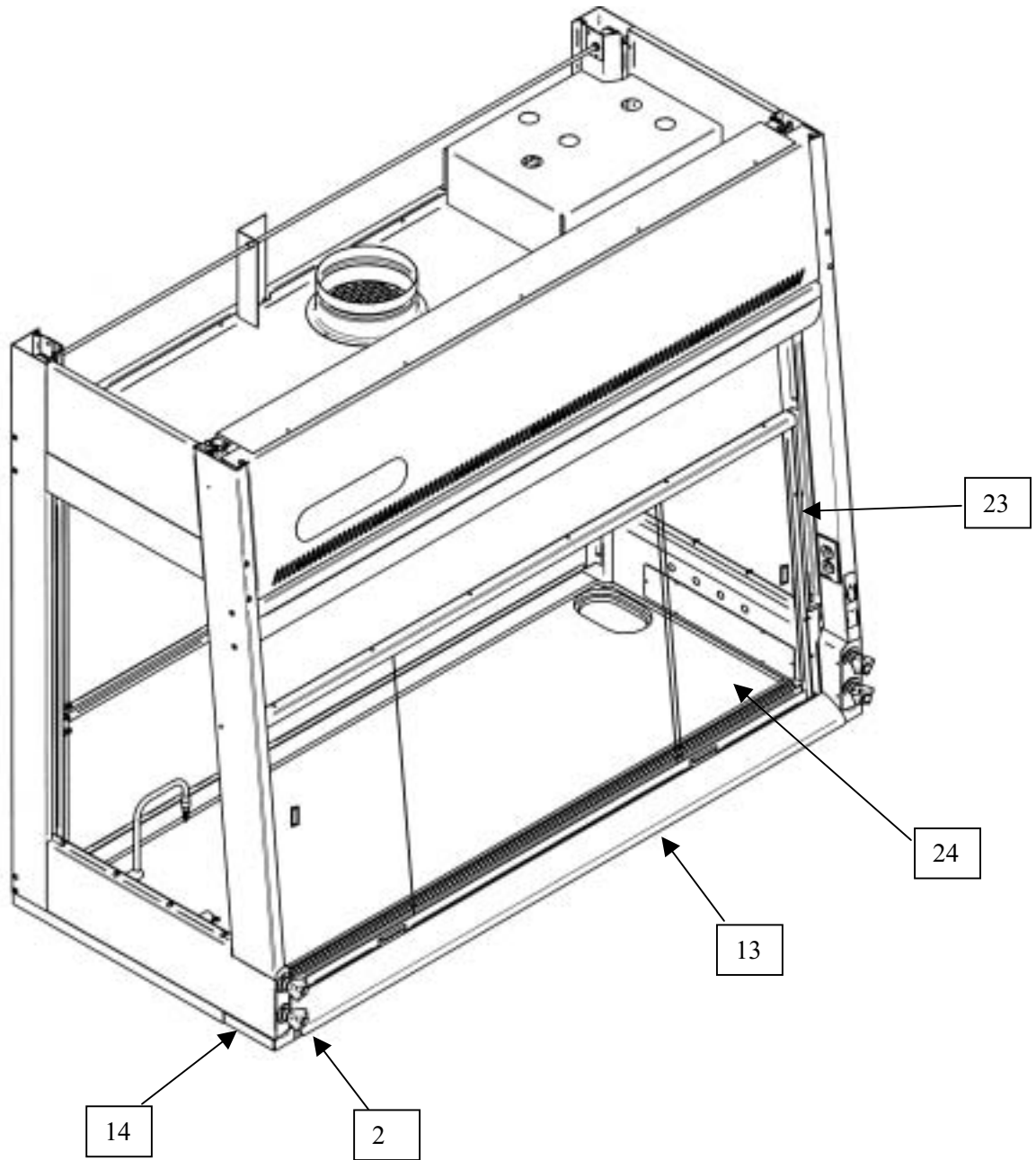

Figure A-2



APPENDIX B

PROTECTOR

CLASSMATE

DIMENSIONS

Standard Education Hood

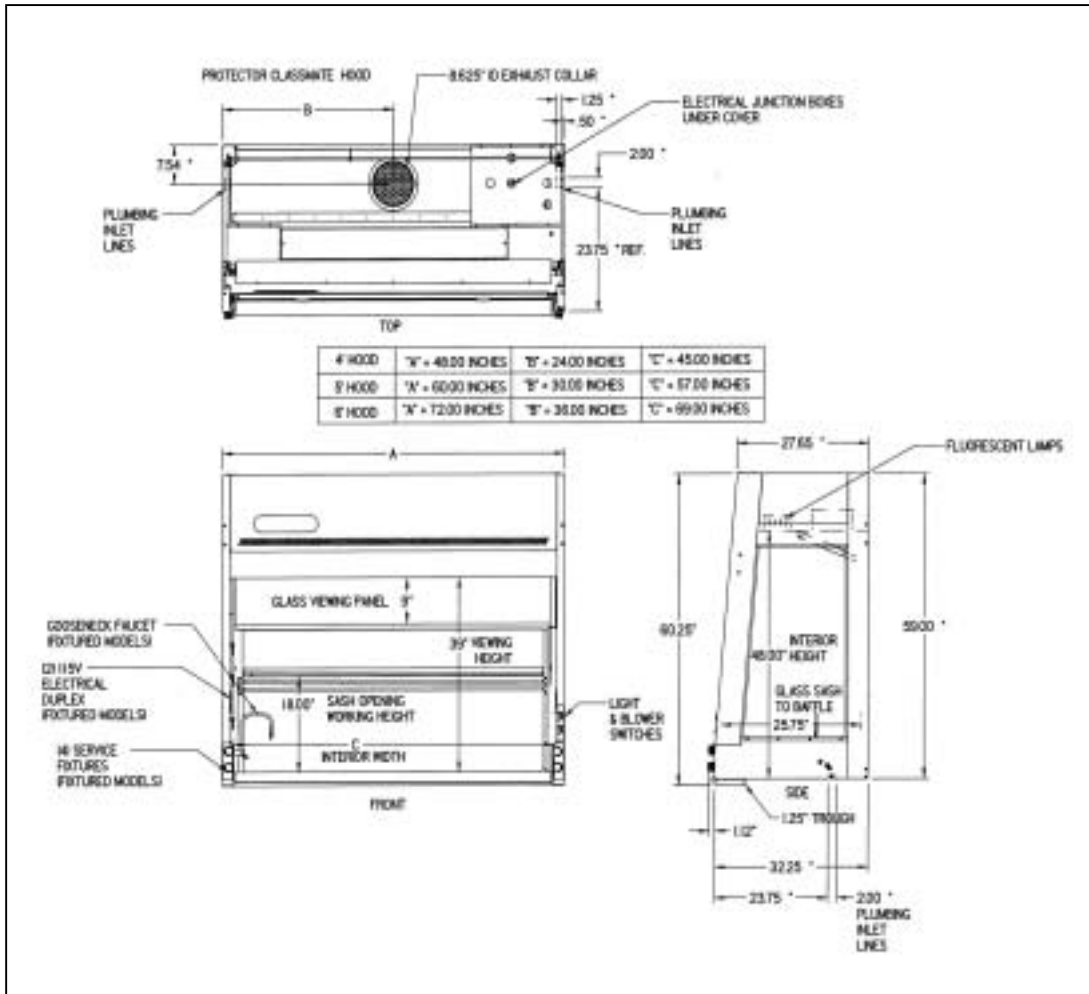

APPENDIX C

PROTECTOR

CLASSMATE FUME

HOOD

SPECIFICATIONS

Electrical Data

Cabinet Model	Electrical Requirements
6970400, 6970401	115 VAC – 60 Hz, 1 Phase – 12 Amps
6970500, 6970501	115 VAC – 60 Hz, 1 Phase – 12 Amps
6970600, 6970601	115 VAC – 60 Hz, 1 Phase – 16 Amps
6971400, 6971401	115 VAC – 60 Hz, 1 Phase – 16 Amps
6971500, 6971501	115 VAC – 60 Hz, 1 Phase – 16 Amps
6971600, 6971601	115 VAC – 60 Hz, 1 Phase – 16 Amps

Environmental Conditions

- Indoor use only.
- Maximum altitude: 6562 feet (2000 meters).
- Ambient temperature range: 41° to 104°F (5° to 40°C).
- Maximum relative humidity: 80% for temperatures up to 88°F (31°C), decreasing linearly to 50% relative humidity at 104°F (40°C).
- Main supply voltage fluctuations not to exceed ±10% of the nominal voltage.

- Transient over-voltages according to Installation Categories II (Over-voltage Categories per IEC 1010). Temporary voltage spikes on the AC input line that may be as high as 1500V for 115V models and 2500V for 230V models are allowed.
- Used in an environment of Pollution degrees 2 (i.e., where normally only non-conductive atmospheres are present). Occasionally, however, a temporary conductivity caused by condensation must be expected, in accordance with IEC 664.

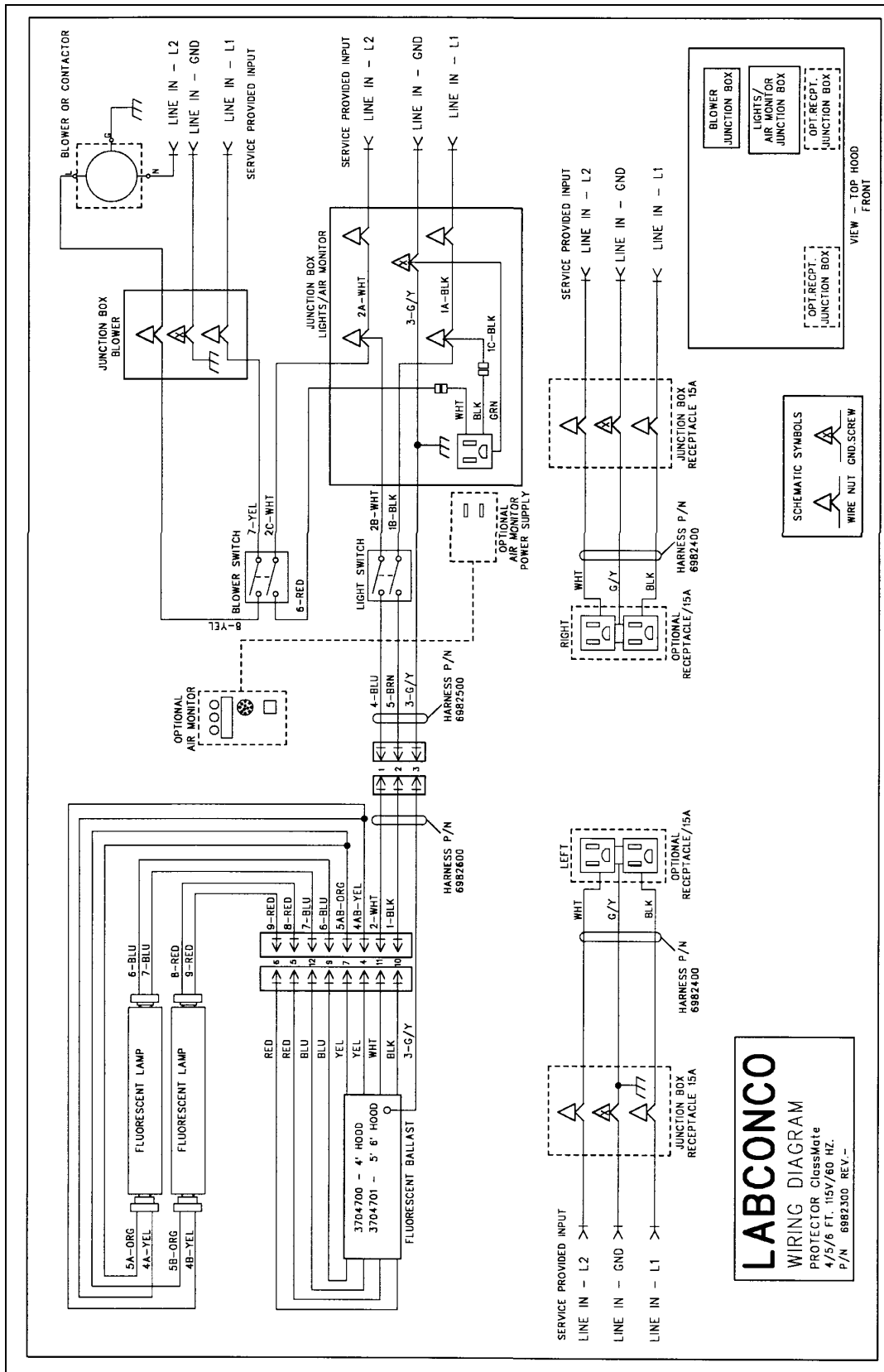

APPENDIX D

PROTECTOR

CLASSMATE FUME

HOOD

ACCESSORIES

Work Surfaces

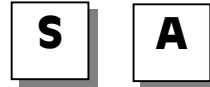

The solid epoxy work surfaces are 1.25" thick and are dished to contain a primary spill. The work surface rests on the storage cabinets and the fume hood rests on the work surface. The work surface rests immediately behind the secondary spill trough provided on all Protector ClassMate Fume Hood models.

Catalog #	Size	Cupsink	Work Surface Dimensions
6986400	4'	None	48"w x 25.9"d x 1.25" thick
6986401	4'	Left Only	48"w x 25.9"d x 1.25" thick
6986402	4'	Right Only	48"w x 25.9"d x 1.25" thick
6986403	4'	Both Sides	48"w x 25.9"d x 1.25" thick

6986500	5'	None	60"w x 25.9"d x 1.25" thick
6986501	5'	Left Only	60"w x 25.9"d x 1.25" thick
6986502	5'	Right Only	60"w x 25.9"d x 1.25" thick
6986503	5'	Both Sides	60"w x 25.9"d x 1.25" thick

6986600	6'	None	72"w x 25.9"d x 1.25" thick
6986601	6'	Left Only	72"w x 25.9"d x 1.25" thick
6986602	6'	Right Only	72"w x 25.9"d x 1.25" thick
6986603	6'	Both Sides	72"w x 25.9"d x 1.25" thick

S

A

Cupsinks

The cupsinks are ordered separately if required for your work surface.

Catalog #	Description
4005200	Durcon CS-4, 3 x 6 Oval Cupsink

S

A

Storage Cabinets

Labconco manufactures four types of Storage Cabinets – Acid, Solvent, Standard Base, and Vacuum Pump.

Protector® Acid Storage Cabinets have been engineered to efficiently store and ventilate corrosive materials and include an interior plastic liner to protect the metal from corrosion.

Protector® Solvent Storage Cabinets are designed to efficiently store flammable materials and includes a 1-1/2" double wall construction for fire protection.

Protector® Standard Base Storage Cabinets are utilized for general storage and are not recommended for corrosive or flammable materials.

Protector® Vacuum Pump Storage Cabinets are utilized for vacuum pump storage.

All cabinets feature 18 gauge steel construction with epoxy coated paint, to give you both a durable and chemically resistant finish that ensures many years of quality service.

All the model numbers are listed next for your convenience in ordering.

Size/Description	SOLVENT			ACID		
	Dual Doors	Right Hinge	Left Hinge	Dual Doors	Right Hinge	Left Hinge
48"	9902000	-	-	9901000	-	-
36"	9902100	-	-	9901100	-	-
30"	9902200	-	-	9901200	-	-
24"	-	9902300	9902400	-	9901300	9901500
18"	-	-	-	-	9901400	9901600
12"	-	-	-	-	-	-
48" w/Self Closing Doors	9903000	-	-	-	-	-
36" w/Self Closing Doors	9903100	-	-	-	-	-
30" w/Self Closing Doors	9903200	-	-	-	-	-
24" w/Self Closing Doors	-	9903300	9903400	-	-	-
24" ADA	-	9906000	9906100	-	9905000	9905200
24" ADA w/Self Closing Doors	-	9906200	9906300	-	-	-
18" ADA	-	-	-	-	9905100	9905300
12" ADA	-	-	-	-	-	-

Size/Description	STANDARD BASE			VACUUM PUMP		
	Dual Doors	Right Hinge	Left Hinge	Dual Doors	Right Hinge	Left Hinge
48"	9900000	-	-	-	-	-
36"	9900100	-	-	-	-	-
30"	9900200	-	-	-	-	-
24"	-	9900300	9900600	-	-	-
18"	-	9900400	9900700	-	9907000	9907100
12"	-	9900500	9900800	-	-	-
48" w/Self Closing Doors	-	-	-	-	-	-
36" w/Self Closing Doors	-	-	-	-	-	-
30" w/Self Closing Doors	-	-	-	-	-	-
24" w/Self Closing Doors	-	-	-	-	-	-
24" ADA	-	9904000	9904300	-	-	-
24" ADA w/Self Closing Doors	-	-	-	-	-	-
18" ADA	-	9904100	9904400	-	-	-
12" ADA	-	9904200	9904500	-	-	-

Wood Cabinets

Consult Labconco Ventilation Ventures Team for pricing and availability of wood cabinets.

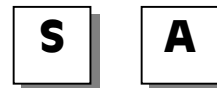

Remote Blowers

Labconco supplies a full line of coated steel, fiberglass, and PVC blowers, which are too numerous to list here. Consult Labconco Ventilation Ventures Team to request a blower brochure or if you need help with blower selection and sizing.



S

A

Ductwork and Accessories

Labconco supplies a full line of ductwork, couplings, elbows, dampers, T-connectors, Y-connectors, reducers, and zero pressure weather caps. Consult Labconco Ventilation Ventures Team to request the blower brochure, which has the ductwork accessories or if you need help with selection.

S

A

Service Fixtures

Your Protector ClassMate Fume Hood is equipped to mount up to four service fixtures, two per side. The service fixtures include serrated hose connector, valve, fittings, and outlet plumbing. Supply tubing ordered separately as shown below:

Catalog #	Qty	Description
4889900	1	5.5' Copper Tubing 1/4" O.D.
4921100	1	5.5' Brass Tubing (GAS) 1/4" O.D.

See Chapter 7 “Installing Additional Service Fixtures” for specific part numbers.

S

A

Dual Exhaust Adapter for Back to Back Hoods

The common exhaust adapter allows you to duct two back-to-back Protector ClassMate Fume Hoods from two 8" (8.62" O.D. pipe) exhaust stacks to one 12" (12.00" O.D. pipe) exhaust stack.

Catalog #	Description
6987000	Dual Exhaust Adapter 8 x 8 x 12

S

A

Digital 335 Airflow Monitor

The digital airflow monitor with low flow alarm allows you to continuously monitor face velocity through the fume hood opening.

Catalog #	Description
9743203	Guardian Digital 335 Airflow Monitor

See *Chapter 7: “Installing Guardian Digital Monitor”* for installation.

Distillation Grids



The distillation grids allow the hood user to mount motors, stirrers, and other apparatus’.

Catalog #	Description
6973300	4' Hood Distillation Grid Kit
6973301	5' Hood Distillation Grid Kit
6973302	6' Hood Distillation Grid Kit

See *Chapter 7: “Distillation Grids-Field Installation”* for installation.

115V Electrical Duplex Outlet



You can install a 115V electrical duplex outlet in the field. See *Chapter 7: “Installing a 115V Electrical Duplex Outlet”*. Order the following parts for installation:

Qty.	Part No.	Description
1 ea.	6982400	Outlet Harness 115V 15A
1 ea.	1885608	Screw, #6-32 x .50 Type F Oval Head Black
1 ea.	1230700	Receptacle, Duplex 115V, 15A Gray
1 ea.	4922401	Wall Plate, Duplex Receptacle Gray
2 ea.	1220300	Cable Connector

Decorative Rear Panels

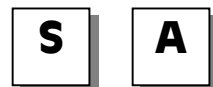

The decorative rear panels allow the upper back of the hood to be protected and more aesthetic. This accessory can be purchased when the hood is placed in the middle of the room where the back of the hood is exposed.

Catalog #	Description
6987300	4' Decorative Rear Panel
6987301	5' Decorative Rear Panel
6987302	6' Decorative Rear Panel

APPENDIX E

QUICK CHART FOR

PROTECTOR

CLASSMATE FUME

HOOD

Model Number	6970400 6970401	6970500 6970501	6970600 6970601	6971400 6971401	6971500 6971501	6971600 6971601
Model Description	4' Standard	5' Standard	6' Standard	4' w/ Sash Stop Energy Saving	5' A-Style Energy Saving	6' A-Style Energy Saving
Sash Type	Vertical- Rising Pivoting	Vertical- Rising Pivoting	Vertical- Rising Pivoting	Vertical- Rising w/Sash Stop	A-Style Combination	A-Style Combination
Operating Sash Height (in)	18.00	18.00	18.00	15.00	30.00	30.00
Operating Sash Width (in)	45.00	57.00	69.00	45.00	26.00	32.00
Total Open Area (Sq. Ft.) Includes bypass air under airfoil	5.70	7.30	8.90	4.70	5.50	6.80
Average Face Velocity (FPM)	100±10	100±10	100±10	100±10	100±10	100±10
Total Air Volume Displacement (CFM)	570	730	890	470	550	680
Hood Static Pressure Loss (in H ₂ O)	0.24	0.39	0.51	0.16	0.22	0.30
Average Face Velocity (FPM)	80±10	80±10	80±10	80±10	80±10	80±10
Total Air Volume Displacement (CFM)	460	590	710	380	440	550
Hood Static Pressure Loss (in H ₂ O)	0.16	0.26	0.33	0.11	0.14	0.20
Average Face Velocity (FPM)	60±10	60±10	60±10	60±10	60±10	60±10
Total Air Volume Displacement (CFM)	340	440	540	280	330	410
Hood Static Pressure Loss (in H ₂ O)	0.09	0.14	0.19	0.06	0.08	0.11

The following calculation is used:

Total Air Volume Displacement (CFM)=Total Open
Area (Sq. Ft.) *Average Face Velocity (FPM).

APPENDIX F

REFERENCES

Many excellent reference texts and booklets are currently available. The following is a brief listing:

Laboratory Ventilation Standards

Federal Register 29 CFR Part 1910

Non-mandatory recommendations from "Prudent Practices".

- Fume hoods should have a continuous monitoring device
- Face velocities should be between 60-100 linear feet per minute (lfpm)
- Average 2.5 linear feet of hood space per person

Occupational Health and Safety

U.S. Department of Labor

200 Constitution Avenue N.W.

Washington, DC 20210

(202) 523-1452

Industrial Ventilation-ACGIH

- Fume hood face velocities between 60-100 lfpm
- Maximum of 125 lfpm for radioisotope hoods
- Duct velocities of 1000-2000 fpm for vapors, gasses and smoke
- Stack discharge height 1.3-2.0 x building height
- Well designed fume hood containment loss, <0.10 ppm

Industrial Ventilation, A Manual of Recommended Practice.

24th Edition, 2001

American Conference of Governmental Industrial Hygienists

1330 Kemper Meadow drive

Cincinnati, OH 45240-1634

(513) 742-2020

ASHRAE 110-1995 Method of Testing Performance of Fume Hoods

Evaluates fume hood's containment characteristics

- Three part test: Smoke generation, Face velocity profile, Tracer gas release @ 4 liters per minute
- Rated As Manufactured (AM), As Installed (AI) and As Used (AU)

American Society of Heating, Refrigerating, and Air Conditioning Engineers

1791 Tullie Circle N.E.

Atlanta, GA 30329

(404) 636-8400

ANSI Z9.5-1993 Laboratory Standard

Covers entire laboratory ventilation system.

- Vertical stack discharge @ 2000-3000 fpm
- New and remodeled hoods shall have a monitoring device
- Ductless hoods should only be used with non-hazardous materials
- Fume hood face velocities between 80-120 fpm

American Industrial Hygiene Association

2700 Prosperity Avenue, Suite 250

Fairfax, VA 22031

(703) 849-8888

SEFA 1-2002

- Fume hood face velocities based on toxicity levels of chemicals
 - Class A – 125 to 150 fpm
 - Class B – 80 to 100 fpm
 - Class C – 75 to 80 fpm
- Test method – face velocity profile and smoke generation

Scientific Equipment & Furniture Association

1028 Duchess Drive

McLean, VA 22102

(703) 538-6007

NFPA 45 – 2002 Fire Protection for Laboratories Using Chemicals

- Laboratory hoods should not be relied on for explosion protection
- Exhaust air from fume hoods should not be recirculated
- Services should be external to the hood
- Canopy hoods only for non-hazardous applications
- Materials of construction should have flame spread of 25 or less
- 80 to 120 fpm to prevent escape

NFPA 30 – 2000 Flammable and Combustible Liquids Code

- Approved cabinets may be metal or wood
- Vent location on cabinets are required
- Venting of cabinets not a requirement

National Fire Protection Association
1 Batterymarch Park
P.O. Box 9101
Quincy, MA 02269-9101
(800) 344-3555

General References

American Conference of Governmental Industrial Hygienists. *Industrial Ventilation, A Manual of Recommended Practice*, Cincinnati, OH: 1995.

ASHRAE Standard Committee. *ASHRAE Standard Atlanta*: ASHRAE Publications Sales Department, 1995

British Standards Institution, *Laboratory Fume Cupboards*. Parts 1, 2 and 3, London: 1990

Department of Labor, Occupational Safety and Health Administration, *29 CFR Part 1910, Occupational Exposures to Hazardous Chemicals in Laboratories, Final Rule*. Vol. 55, No. 21. Washington D.C.:1990

DiBerardinis, L. et al. *Guides for Laboratory Design, Health and Safety Considerations*. Wiley & Sons, 1987

McDermott, Henry, *Handbook of Ventilation for Contaminant Control, 2nd Edition*. Butterworth Publishers, 1985.

Miller, Brinton M. et al. *Laboratory Safety: Principles and Practices*. American Society for Microbiology, Washington, D.C.: 1986

NIH Guidelines for the Laboratory Use of Chemical Carcinogens. NIH Publication No. 81-2385.

Rayburn, Stephen R. *The Foundation of Laboratory Safety, A Guide for the Biomedical Laboratory*. Springer-Verlag, New York: 1990

Sax, N. Irving and Lewis, JR., Richard J. *Rapid Guide to Hazardous Chemicals in the Workplace*. Van Nostrand Reinhold, 1987.

Appendix F: References

Schilt, Alfred A. *Perchloric Acid and Perchlorates*. The G. Frederick Smith Chemical Company, Columbus, OH: 1979.

Steere, Norman. *CRC Handbook of Laboratory Safety*, 2nd Edition. CRC Press, 1971.

DECLARATION OF CONFORMITY

Application Council Directive(s): 73/23/EEC, 89/336/EEC

Standard(s) to which conformity is declared: EN61010, EN55022, EN50082-1

Manufacturer's Name: Labconco Corporation

Manufacturer's Address: 8811 Prospect Avenue
Kansas City, MO 64132 USA

Importer's Name: See Shipping/Customs Documents*

Importer's Address: See Shipping/Customs Documents for your equipment

Type of Equipment: Laboratory Equipment - Educational Fume Hoods

Model No.: 6970400 thru 6970401 48" Protector ClassMate without/with fixtures
6970500 thru 6970501 60" Protector ClassMate without/with fixtures
6970600 thru 6970601 72" Protector ClassMate without/with fixtures
6971400 thru 6971401 48" Energy Saving Protector ClassMate without/with fixtures
6971500 thru 6971501 60" Energy Saving Protector ClassMate without/with fixtures
6971600 thru 6971601 72" Energy Saving Protector ClassMate without/with fixtures

Serial No.: Various – See Individual Declaration

Year of Manufacture: 2001 and subsequent

I, the undersigned, hereby declare that the equipment specified above conforms to the above Directive(s) and Standard(s).

See individual Declaration of Conformity which
will be signed by the importer for your country.

Place: _____
(Signature)

Date: _____
(Full Name)

(Position)

*An individual version of this declaration is included with your shipping/customs documentation.

PRODUCT REGISTRATION CARD

By registering your product, you will receive these important benefits: • Warranty Confirmation • Product Registration
• Product Protection • Free LabbyWear™ Merchandise

NAME _____ TITLE _____

DEPARTMENT _____ INSTITUTION _____

ADDRESS _____

CITY/STATE/ZIP/COUNTRY _____

TELEPHONE _____ EXT _____ FAX _____ E-MAIL _____

Which of the following comes closest to describing the type of activity in which you are engaged?

- Quality Control Teaching/Instructional Testing Other (please specify)
 Clinical/Diagnostic Research & Development Production

Of what type organization is your work a part?

- Industrial, Manufacturing, Utility Government (except Medical)
 Educational Institution (except Medical School) Independent, Foundation, Consulting
 Medical, Medical School, Hospital, Public Health Other (please specify)

Which comes closest to describing your scientific discipline?

- Biological Science Inorganic Chemistry Physical Chemistry
 Bio-Chemistry Analytical Chemistry/R & D Engineering or Physics
 Polymer Chemistry Analytical Chemistry/Quality Control Other (please specify)
 Organic Chemistry

Which Protector Laboratory Hood did you purchase?

- Fiberglass 48, 60, 72, or 96 Hood PVC Perchloric Acid/Acid Digestion Hood HOPEC Hood
 Stainless Steel Radioisotope Hood Fiberglass Walk-In Hood ClassMate™ Hood
 Stainless Steel Perchloric Acid Hood XL Hood

Model Number* _____ Serial Number* _____ Date of Installation _____

*On most models, model and serial numbers are located behind the front panel in upper left hand corner, near the junction box.

Indicate Labconco accessories purchased with your Protector Hood.

- Acid Storage Cabinet Solvent (flammable) Storage Cabinet Standard Base Cabinet
 Universal Base Stand Work Surface Other _____

How did you learn about the Protector Hoods?

- Dealer Sales Rep Dealer Catalog Colleague Advertisement
 Labconco Sales Rep Labconco Literature Trade Show Internet/WWW
 Other (please specify) _____

What factors most influenced your decision to purchase a Protector Hood?

(Number up to 3, #1 being the most important)

- ___ Appearance ___ Reputation ___ Service Program ___ Performance Specifications
___ Ease of Operation ___ Safety Features ___ Price ___ Dealer Recommendation
___ Availability ___ Colleague Recommendation ___ Other (please specify) _____

From whom did you purchase your Protector Hood? _____
(DEALER)

Please fold card over, tape edges and mail. No postage is required.



PROTECTOR® LABORATORY HOODS

LabbyWear™ is the official uniform of LABsters everywhere! Be a LABster!

As a token of our thanks for returning your Product Registration Card, we would like to send you the LabbyWear of your choice. Please select from one of the three items listed or collect Labby Bucks and redeem for other LabbyWear merchandise. Then just complete the information requested on the reverse side, fold, tape edges and mail.

- T-shirt.** 100% cotton, short-sleeved, white, with Labby The LABster embroidered on the front left side. Specify unisex size.
 - Large
 - XLarge
- Twill cap.** Pigment-dyed, two-color, with six panels and Labby The LABster embroidered on the front.
- Lunch bag.** Insulated, teal with royal blue accent and Labby The LABster embroidered on the front.
- 10 Labby Bucks** and LabbyWear Catalog.



**Labby
The LABster**

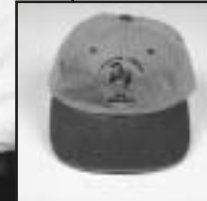

For more information, please contact us:

[ExpotechUSA](#)
[10700 Rockley Road](#)
[Houston, Texas 77099](#)
[USA](#)

[281-496-0900 \[voice\]](#)

[281-496-0400 \[fax\]](#)

E-mail: sales@expotechusa.com

Website: www.ExpotechUSA.com