



# User's Manual

## Protector® Laboratory Fume Hoods

### Premier® Models

4871300, 4871400, 4871500, 4871600, 4880000, 4880100, 4880200,  
4880300, 4880400

6071300, 6071400, 6071500, 6071600, 6080000, 6080100, 6080200,  
6080300, 6080400

7271300, 7271400, 7271500, 7271600, 7280000, 7280100, 7280200,  
7280300, 7280400

9674500, 9683000

### XL™ Models

97001 Series, 97002 Series, 97003 Series, 97004 Series, 97504 Series,  
97505 Series, 97506 Series



Labconco's Mascot,  
Labby the LABster



*Protecting your  
laboratory environment*

**LABCONCO®**

For more information, please contact us:

[ExpotechUSA](#)  
[10700 Rockley Road](#)  
[Houston, Texas 77099](#)  
[USA](#)

[281-496-0900 \[voice\]](#)

[281-496-0400 \[fax\]](#)

E-mail: [sales@expotechusa.com](mailto:sales@expotechusa.com)

Website: [www.ExpotechUSA.com](http://www.ExpotechUSA.com)

## Warranty

Labconco provides a warranty on all parts and factory workmanship. The warranty includes areas of defective material and workmanship, provided such defect results from normal and proper use of the equipment.

The warranty for all Labconco products will expire one year from date of installation or two years from date of shipment from Labconco, whichever is sooner, except the following:

- Purifier® Delta® Series Biological Safety Cabinets, and PuriCare™ Bedding Disposal Stations carry a three-year warranty from date of installation or four years from date of shipment from Labconco, whichever is sooner.
- Carts carry a lifetime warranty.
- Glass is not warranted from breakage due to accident or mishandling.

This limited warranty covers parts and labor, but not transportation and insurance charges. In the event of a warranty claim, contact Labconco Corporation or the dealer who sold you the product. If the cause is determined to be a manufacturing fault, the dealer or Labconco Corporation will repair or replace all defective parts to restore the unit to operation. Under no circumstances shall Labconco Corporation be liable for indirect, consequential, or special damages of any kind. This statement may be altered by a specific published amendment. No individual has authorization to alter the provisions of this warranty policy or its amendments. Lamps and filters are not covered by this warranty. Damage due to corrosion or accidental breakage is also not covered.

## Limitation of Liability

The disposal and/or emission of substances used in connection with this equipment may be governed by various federal, state, or local regulations. All users of this equipment are required to become familiar with any regulations that apply in the user's area concerning the dumping of waste materials in or upon water, land, or air and to comply with such regulations. Labconco Corporation is held harmless with respect to user's compliance with such regulations.

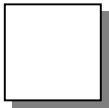

---

**Part #9825700 Rev C, ECO C299**

---

# TABLE OF CONTENTS

<b>CHAPTER 1: INTRODUCTION</b>	1
About This Manual	2
Typographical Conventions	3
Your Next Step	4
<b>CHAPTER 2: PREREQUISITES</b>	7
Location Requirements	8
Support Requirements	8
Exhaust Requirements	8
Exhaust Requirements Table	9
Electrical Requirements	10
Service Line Requirements	10
Space Requirements	10
Your Next Step	10
<b>CHAPTER 3: GETTING STARTED</b>	11
Unpacking Your Fume Hood	12
Removing the Shipping Skid	13
Sash Weight Release	13
Installing the Hood on a Supporting Structure & Work Surface	14
Connecting to the Hood Exhaust System	16
Connecting the Electrical Supply Source	16
Connecting the Service Lines	18
Sealing the Protector Hood	19
Certifying the Protector Fume Hood	19
Your Next Step	20
<b>CHAPTER 4: PERFORMANCE FEATURES AND SAFETY</b>	
<b>PRECAUTIONS</b>	21
Performance Features	21
Safety Precautions	25
Your Next Step	27

<b>CHAPTER 5: USING YOUR PROTECTOR</b>	29
Operating the Vertical Rising Sash	29
Operating the A-Style Combination Sash	30
Operating the Blower	30
Operating the Lights	30
Working in your Protector Fume Hood	31
Your Next Step	32
<b>CHAPTER 6: MAINTAINING YOUR FUME HOOD</b>	33
Routine Maintenance Schedule	34
Routine Service Operations	35
Your Next Step	35
<b>CHAPTER 7: MODIFYING YOUR FUME HOOD</b>	37
Installing Work Surfaces	37
Installing Ceiling Enclosures above the Fume Hood	38
Installing Rear Panels behind the Fume Hood	38
Installing Additional Service Fixtures	39
Installing Guardian Digital Airflow Monitor	39
Distillation Grids – Field Installation	40
Sash Stop Kit-Field Installation	40
Installing an Electrical Duplex Outlet	41
Your Next Step	41
<b>CHAPTER 8: TROUBLESHOOTING</b>	43
<b>APPENDIX A: PROTECTOR COMPONENTS</b>	47
<b>APPENDIX B: PROTECTOR DIMENSIONS</b>	51
<b>APPENDIX C: PROTECTOR SPECIFICATIONS</b>	55
<b>APPENDIX D: REFERENCES</b>	61
<b>APPENDIX E: DISASSEMBLY AND REASSEMBLY INSTRUCTIONS</b>	65
<b>DECLARATION OF CONFORMITY</b>	68

---

# CHAPTER 1

## INTRODUCTION

Congratulations on your purchase of a Labconco Protector® Laboratory Fume Hood. Your Protector® Laboratory Fume Hood is designed to protect you. It is the result of Labconco's more than 50 years experience in manufacturing fume hoods, and users like you suggested many of its features to us.

The Labconco Protector Fume Hood has been engineered to provide maximum visibility in a laboratory, and effectively contain toxic, noxious, or other harmful materials when properly installed. The Protector offers many unique features to enhance safety, performance, and visibility. To take full advantage of them, please acquaint yourself with this manual and keep it handy for future reference. If you are unfamiliar with how fume hoods operate, please review *Chapter 4: Performance Features and Safety Precautions* before you begin working in the fume hood. Even if you are an experienced fume hood user, please review *Chapter 5: Using Your Fume Hood*, which describes your Protector Hood's features so that you can use the hood efficiently.

## About This Manual

This manual is designed to help you learn how to install, use, and maintain your laboratory fume hood. Instructions for installing optional equipment on your hood are also included.

*Chapter 1: Introduction* provides a brief overview of the laboratory fume hood, explains the organization of the manual, and defines the typographical conventions used in the manual.

*Chapter 2: Prerequisites* explains what you need to do to prepare your site before you install your laboratory fume hood. Electrical and service requirements are discussed.

*Chapter 3: Getting Started* contains the information you need to properly unpack, inspect, install, and certify your laboratory fume hood.

*Chapter 4: Performance Features and Safety Precautions* explains how the Protector operates and the appropriate precautions you should take when using the fume hood.

*Chapter 5: Using Your Protector* discusses the basic operation of your fume hood. Information on how to prepare, use and shut down your Protector Hood are included.

*Chapter 6: Maintaining Your Protector* explains how to perform routine maintenance on your fume hood.

*Chapter 7: Modifying Your Protector* explains how to modify the fume hood or add accessories.

*Chapter 8: Troubleshooting* contains a table of problems you may encounter while using your laboratory fume hood including the probable causes of the problems and suggested corrective actions.

*Appendix A: Protector Hood Components* contains labeled diagrams of all of the components of the fume hoods.

*Appendix B: Protector Hood Dimensions* contains comprehensive diagrams showing all of the dimensions for the laboratory fume hoods.

*Appendix C: Protector Hood Specifications* contains the electrical requirements for laboratory fume hood. Wiring diagrams are also included.

*Appendix D: References* lists the various resources available that deal with laboratory fume hoods.

## Typographical Conventions

Recognizing the following typographical conventions will help you understand and use this manual:

- Book, chapter, and section titles are shown in italic type (e.g., *Chapter 3: Getting Started*).
- Steps required to perform a task are presented in a numbered format.
- Comments located in the margins provide suggestions, reminders, and references.

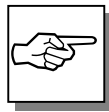

- Critical information is presented in boldface type in paragraphs that are preceded by the exclamation icon. Failure to comply with the information following an exclamation icon may result in injury to the user or permanent damage to fume hood.
- Critical information is presented in boldface type in paragraphs that are preceded by the wrench icon. These operations should only be performed by a trained certifier or contractor. Failure to comply with the information following a wrench icon may result in injury to the user or permanent damage to your hood.
- Important information is presented in capitalized type in paragraphs that are preceded by the pointer icon. It is imperative that the information contained in these paragraphs be thoroughly read and understood by the user.
- A number icon precedes information that is specific to a particular model of laboratory fume hood. The 4' icon indicates the text is specific to the 4-foot wide model. The 5' icon indicates the text is specific to the 5-foot model, etc.
- The S icon indicates the text is specific to the standard model.
- The A icon indicates the text is specific to the A-Style Combination Sash Model.

## Your Next Step

If your Fume Hood needs to be installed, proceed to *Chapter 2: Prerequisites* to ensure your installation site meets all of the requirements. Then, go to *Chapter 3: Getting Started* for instructions on how to install your laboratory fume hood and make all of the necessary connections.

If you would like to review how laboratory fume hoods operate, go to *Chapter 4: Performance Features and Safety Precautions*.

For information on the operational characteristics of your laboratory fume hood, go to *Chapter 5: Using Your Protector Hood*.

If your laboratory fume hood is installed and you need to perform routine maintenance on the cabinet, proceed to *Chapter 6: Maintaining Your Protector Hood*.

For information on making modifications to the configuration of your fume hood, go to *Chapter 7: Modifying Your Laboratory Fume Hood*.

Refer to *Chapter 8: Troubleshooting* if you are experiencing problems with your fume hood.



---

# CHAPTER 2

## PREREQUISITES

Before you install your laboratory fume hood, you need to prepare your site for installation. Carefully examine the location where you intend to install your hood. You must be certain that the area is level and of solid construction. In addition, a dedicated source of electrical power must be located near the installation site.

Carefully read this chapter to learn the requirements for your installation site:

- The location requirements.
- The support requirements.
- The exhaust requirements.
- The electrical power requirements.
- The service line requirements.
- The space requirements.

Refer to *Appendix B: Protector Hood Dimensions* for complete fume hood dimensions.

Refer to *Appendix C: Protector Hood Specifications* for complete laboratory fume hood electrical and environmental conditions, specifications and requirements.

## Location Requirements



The fume hood should be located away from traffic patterns, doors, windows, fans, ventilation registers, and any other air-handling device that could disrupt its airflow patterns. All windows in the room should be closed.

## Support Requirements



**DO NOT** install the fume hood on a cart, dolly, or mobile bench. **ALL** Protector Hood installations must be permanent and stationary. The supporting structure usually consists of a base cabinet and chemically resistant work surface.

## Exhaust Requirements

The exhaust duct connection has been designed for 12" nominal duct (12.75" OD) to allow for minimum static pressure loss while operating at 100 fpm face velocities. The 12" diameter exhaust duct also allows for proper transport velocities away from the hood in the 1000 fpm to 2500 fpm range. The proper exhaust volume and static pressure loss are listed next for each hood model:

**NOTE:** The 4' integral blower model uses 10" (10.75" OD) duct.

Hood Size	Standard Model Description	Full Open 28" Sash Opening		
		Face Velocity	Exhaust Volume	Static Pressure Loss
4'	48" Protector Hood	80 fpm	590 CFM	0.11" H <sub>2</sub> O
		100 fpm	730 CFM	0.16" H <sub>2</sub> O
5'	60" Protector Hood	80 fpm	770 CFM	0.15" H <sub>2</sub> O
		100 fpm	960 CFM	0.24" H <sub>2</sub> O
6'	72" Protector Hood	80 fpm	940 CFM	0.18" H <sub>2</sub> O
		100 fpm	1180 CFM	0.28" H <sub>2</sub> O
8'	96" Protector Hood	80 fpm	1330 CFM	0.12" H <sub>2</sub> O
		100 fpm	1660 CFM	0.19" H <sub>2</sub> O
10'	120" Protector Hood	80 fpm	1700 CFM	0.18" H <sub>2</sub> O
		100 fpm	2130 CFM	0.28" H <sub>2</sub> O
12'	144" Protector Hood	80 fpm	2080 CFM	0.25" H <sub>2</sub> O
		100 fpm	2600 CFM	0.39" H <sub>2</sub> O
16'	192" Protector Hood	80 fpm	2840 CFM	0.15" H <sub>2</sub> O
		100 fpm	3550 CFM	0.23" H <sub>2</sub> O
<b>60% Open 18" Sash Opening (sash stop required)</b>				
Hood Size	Standard Model Description	Face Velocity	Exhaust Volume	Static Pressure Loss
4'	48" Protector Hood	80 fpm	380 CFM	0.05" H <sub>2</sub> O
		100 fpm	470 CFM	0.07" H <sub>2</sub> O
5'	60" Protector Hood	80 fpm	490 CFM	0.07" H <sub>2</sub> O
		100 fpm	610 CFM	0.10" H <sub>2</sub> O
6'	72" Protector Hood	80 fpm	600 CFM	0.07" H <sub>2</sub> O
		100 fpm	750 CFM	0.11" H <sub>2</sub> O
8'	96" Protector Hood	80 fpm	850 CFM	0.05" H <sub>2</sub> O
		100 fpm	1060 CFM	0.08" H <sub>2</sub> O
10'	120" Protector Hood	80 fpm	1100 CFM	0.08" H <sub>2</sub> O
		100 fpm	1370 CFM	0.12" H <sub>2</sub> O
12'	144" Protector Hood	80 fpm	1340 CFM	0.10" H <sub>2</sub> O
		100 fpm	1670 CFM	0.16" H <sub>2</sub> O
16'	192" Protector Hood	80 fpm	1830 CFM	0.07" H <sub>2</sub> O
		100 fpm	2290 CFM	0.10" H <sub>2</sub> O

Proper blower selection can be determined from these exhaust requirements and the total system static pressure loss. Contact Labconco Customer Service for assistance in sizing a blower system.

## Electrical Requirements

The Protector Hood models feature internal wiring for the fluorescent light assembly and light switch. All internal wiring is terminated at the single point wiring junction box for hook-up by a qualified electrician. The blower switch, and light switch wires are also terminated at the single point wiring junction box for hook-up by a qualified electrician. Refer to *Chapter 3: Getting Started* and *Appendix C: Protector Specifications* for the wiring diagram for proper electrical installation.

## Service Line Requirements

All service lines to the laboratory fume hood should be ¼ inch outside diameter, copper (brass for natural gas), and equipped with an easily accessible shut-off valve, should disconnection be required. If the service line pressure exceeds 40 PSI, it must be equipped with a pressure regulator to reduce the line pressure. Please check with local codes for other requirements.

## Space Requirements

The dimensions for the different models are shown in *Appendix B: Protector Dimensions*.

## Your Next Step

After you have determined that the location you have selected accommodates the installation and operational requirements of your fume hood, you are ready to begin installation. Proceed to *Chapter 3: Getting Started*.

---

# CHAPTER 3

## GETTING STARTED

Now that the site for your laboratory fume hood is properly prepared, you are ready to unpack, inspect, install, and certify your unit. Read this chapter to learn how to:

- Unpack and move your Protector Hood.
- Set up the fume hood with the supporting structure and work surface.
- Connect to an exhaust system.
- Connect the electrical supply source.
- Connect the service lines.
- Sealing the Protector Hood to the work surface.
- Arrange certification of your Protector Hood.

Depending upon which model you are installing, you may need common plumbing and electrical installation tools in addition to 5/16", 3/8", 7/16", and 1/2" wrenches, ratchets, sockets, a nut driver set, a flat-blade screwdriver, a Phillips screwdriver, and a carpenter level to complete the instructions in the chapter.



**The Protector Hood models weigh between 400 to 800 lbs. (182-363 kg). The shipping skid allows for lifting with a mechanical lift truck or floor jack. If you must lift the fume hood manually, follow safe-lifting guidelines. Normally, the fume hood can be slid off a hydraulic lift table and**

be placed into position on top of the work surface. **Do not lift by the front air foil.**

## Unpacking Your Laboratory Fume Hood

*The United States Interstate Commerce Commission rules require that claims be filed with the delivery carrier within fifteen (15) days of delivery.*

Carefully remove the shrink-wrap or carton on your fume hood and inspect it for damage that may have occurred in transit. If your unit is damaged, notify the delivery carrier immediately and retain the entire shipment intact for inspection by the carrier.

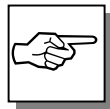

**DO NOT RETURN GOODS WITHOUT THE PRIOR AUTHORIZATION OF LABCONCO. UNAUTHORIZED RETURNS WILL NOT BE ACCEPTED.**

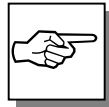

**IF YOUR HOOD WAS DAMAGED IN TRANSIT, YOU MUST FILE A CLAIM DIRECTLY WITH THE FREIGHT CARRIER. LABCONCO CORPORATION AND ITS DEALERS ARE NOT RESPONSIBLE FOR SHIPPING DAMAGES.**

Do not discard the shipping skid or packing material for your fume hood until you have checked all of the components and installed and tested the unit.

Do not remove the fume hood from its shipping skid until it is ready to be placed into its final location. Move the unit by placing a flat, low dolly under the shipping skid, or by using a floor jack.



**Do not move the hood by tilting it onto a hand truck.**

## Removing the Shipping Skid

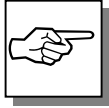

LEAVE THE FUME HOOD ATTACHED TO ITS SHIPPING SKID UNTIL IT IS AS CLOSE TO ITS FINAL LOCATION AS POSSIBLE. MOVE THE HOOD BY USING A SUITABLE FLOOR JACK, OR BY PLACING A FURNITURE DOLLY UNDERDNEATH THE SKID. DO NOT MOVE THE HOOD BY TILTING IT ONTO A HAND TRUCK.

After you verify the fume hood components, move your hood to the location where you want to install it. Should you require disassembly to move the hood, then follow the instructions in Appendix E. Then, follow the steps listed next to remove the shipping skid from your unit.

1. Remove the side panels by unscrewing the Phillips screws.
2. Find the hardware (bolts, washers, nuts) that attach the fume hood to the skid and remove the hardware. Some hardware is on the sides and some is on the back.

## Sash Weight Release

To protect the fume hood from damage in shipment, the sash weight has been secured to the back of the fume hood with four (4) screws. Simply remove the screws and make sure the sash cables are on the pulleys before operation of the sash. On models with more than one sash, the sash weights have been secured to the shipping skid with lag screws. Remove the weights from the skid and attach them to the respective sash cables using the hooks provided.

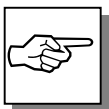

**NOTE:** THE SASH WEIGHT ITSELF WAS INDIVIDUALLY MATCHED FOR THIS SPECIFIC HOOD AND SHOULD NOT BE EXCHANGED ON ANY OTHER UNIT.

## Install the Protector Hood on a Supporting Structure and Work Surface



**The Protector Hood is heavy! Use caution when lifting or moving the unit.**

When installing the Protector Fume Hood onto a chemically-resistant work surface or benchtop, ensure that the structure can safely support the combined weight of the fume hood and any related equipment. The work surface should be at least as wide as the hood to properly support it. **The work surface is aligned flush with the back of the fume hood for good airflow: this will provide the correct spacing under the air foil for proper bypass airflow.**



**WARNING: It is important to support the rear of the work surface and fume hood. The cross support provides support for the bottom of the work surface. Install the cross support after the base cabinets and work surface are leveled and before installing the hood.**

The following are instructions for mounting a cross support:

1. Level the base cabinets and the work surface. Work surface should be placed flush with the back of the fume hood as shown in Figure 3-1.
2. Scribe a line on the wall or back of the base cabinet to locate the support under the work surface.
3. Mount the support by attaching it to the wall or base cabinet.
4. Place the hood on top of the work surface and cross support.

The work surface should be smooth and durable, such as a chemically-resistant epoxy resin. The surface

should be nonporous and resistant to the acids, solvents, and chemicals used in conjunction with the

Protector Fume Hood. The work surface should also contain a dished recessed area for containing primary spills.

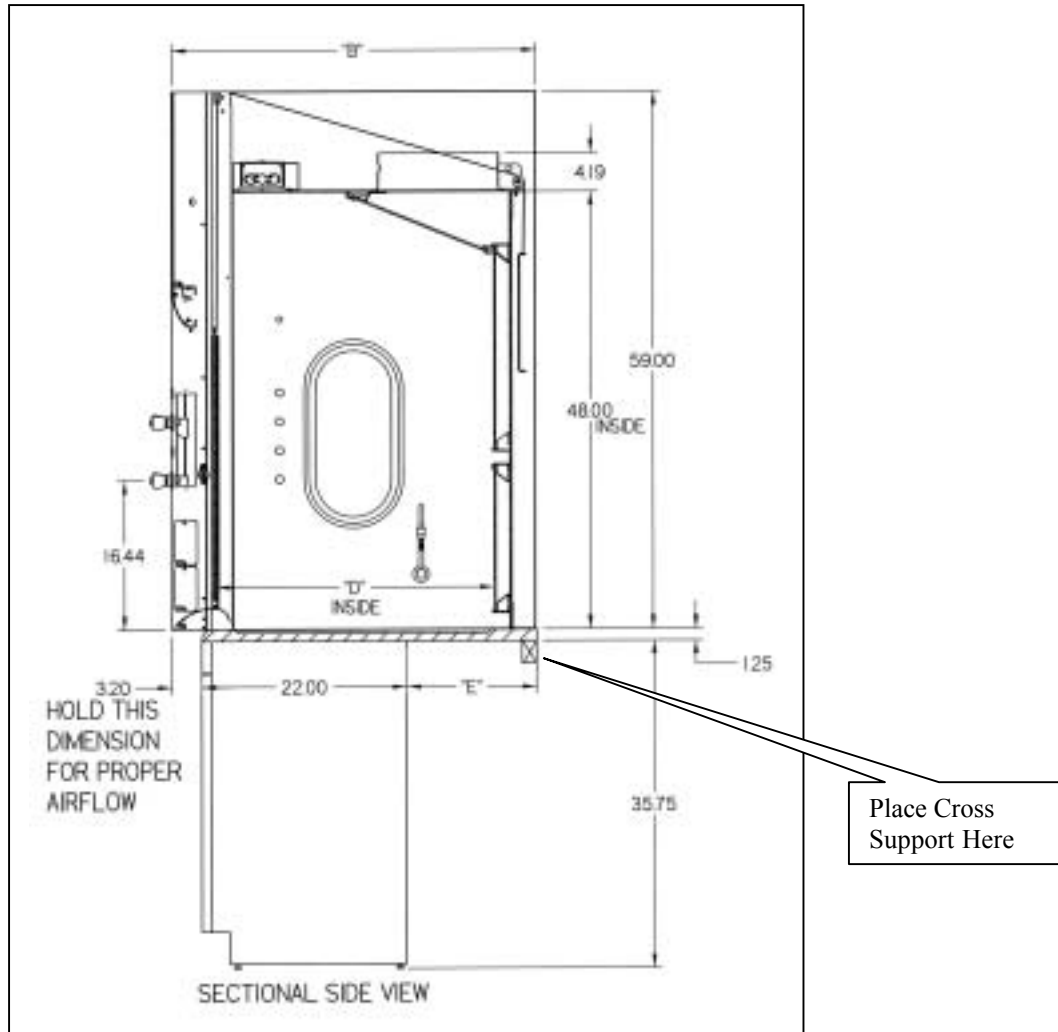

Figure 3-1

Dimensions Shown in Inches			
Hood Depth "B"	Hood Internal Depth "D"	Filler Panel Depth "E"	Work Surface Depth
33.19"	24"	8"	30"
39.19"	30"	14"	36"
45.19"	36"	20"	42"

## Connecting to the Protector Hood Exhaust System



**WARNING:** The weight of the exhaust ductwork system must be supported independently of the hood superstructure. Do not allow this weight to be supported by the hood structure as damage to the hood may occur.



The exhaust connection should be installed by a qualified HVAC contractor.

The exhaust connection on your hood has been designed for 12" nominal pipe (12.75" OD) to allow for minimum static pressure loss with proper transport velocities away from the hood. The 4' integral blower model uses 10" (10.75" OD) duct. Consult Labconco Customer Service should you require help sizing your blower for the exhaust volume and total system static pressure loss.



The selected exhaust duct material should match the hood procedures and chemicals used to ensure compatibility.

## Connecting the Electrical Supply Source to the Protector Fume Hood

Prior to connecting any electrical wiring to the fume hood structure, refer to the hood identification plate for the proper electrical requirements of your specific model.



**WARNING:** The building electrical supply system for Protector Hoods should include overload protection. A switch or circuit breaker should be in close proximity to the equipment and within easy reach of the operator. The switch or circuit breaker is to be marked as the disconnecting device for the equipment. Consult the NEC-2002 for proper installation.

The identification plate, model number, serial number, and electrical connection boxes are accessible from the front of the fume hood by removing the front panel.

The Protector Hood is normally wired for 115 Volt, 60 Hz, 20 Amp or 230Volt, 50 Hz, 10 Amp electrical service. Check the I.D. plate behind the front panel for voltage verification. The number of circuits varies depending on the model. All of the electrical connections are terminated at the single point internal junction box for hook-up by a qualified electrician. The single point internal junction box is used for the connection of the lights, blower, and duplex outlets. Refer to the wiring diagram for your Protector in *Appendix C: Protector Fume Hood Specifications*.

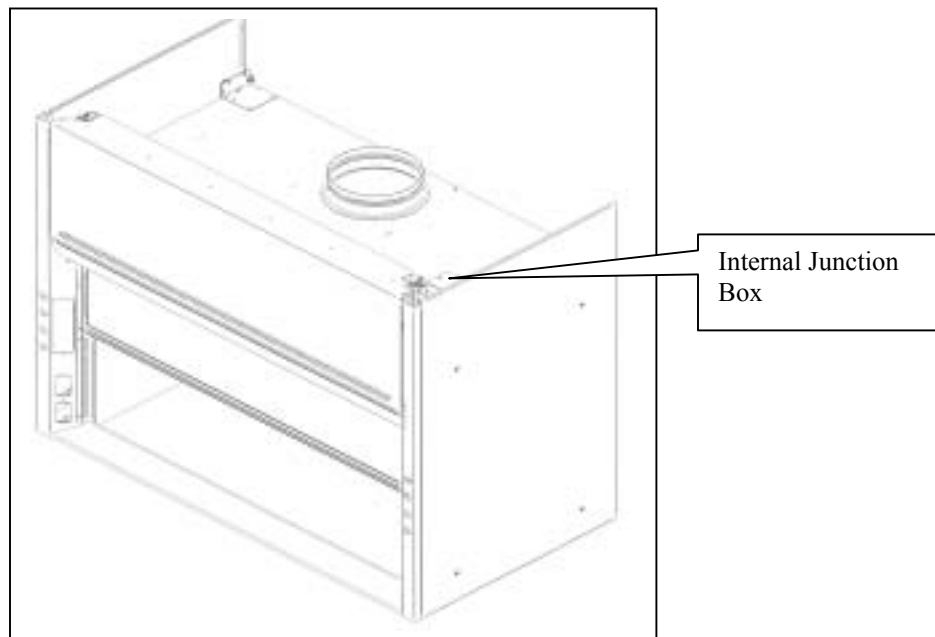

**Figure 3-2**



**All wiring for the fume hood SHOULD be performed by a licensed electrician and conform to all local codes. In most cases, the hood will require the use of shielded conduit to protect the wiring into the hood. The grounding connection shall not be made to the terminal box cover.**

The fluorescent light has been mounted outside the top liner panel and is sealed from vapors inside the hood structure. To change the fluorescent light bulbs in your hood, you must first remove the front panel from the hood. Next remove the screws holding down the light reflector(s). Remove the light reflector(s) and slide out of the way temporarily.

The fluorescent lights are now fully exposed and ready for service. While the fixture is in this position, replace the defective bulbs, and reassemble.

## **Connecting the Service Lines to the Protector Fume Hood**

The hoods with service fixtures have been plumbed from the valve to the hose connector or gooseneck for your installation convenience. Supply tubing shall be provided by the qualified installer. Tubing can enter the hood from above, through the back, or through the work surface to make these connections to the service fixtures.



**NOTE: Inspect all fittings for leakage. Tighten the fittings slightly if needed.**



**CAUTION: Do not use oxygen with any standard service fixture. Contact Labconco Customer Service for oxygen fixture information.**

Should access to the hood plumbing fixture bodies be required, remove the service access plate on the hood front corner posts by loosening their individual screws. (See item 11 Figure A-1, page 48 and 49) The valve body will now be fully exposed for any service work that may be necessary. The service fixtures supplied on your laboratory hood are designed for use with the following services:

- Air
- Cold Water
- Hot Water
- Natural Gas – See caution below
- Vacuum



**WARNING: Contact Labconco Customer Service directly before using any service other than those listed above in these valves to assure full compatibility.**



**CAUTION: Natural gas should be used only in the service fixture that has been pre-plumbed with brass tubing. Sulfur content of the gas could cause deterioration of standard copper supply lines.**

## Sealing the Protector Hood to the Work Surface

When the hood has been set in place, ducted, wired, and plumbed, it should be sealed at the work surface to prevent spilled materials from collecting under the walls of the hood. Materials such as silicone sealants are recommended to seal the hood structure.

## Certifying the Protector Fume Hood

The combination of your laboratory hood, exhaust ductwork, and exhaust blower gives you the flexibility to change the airflow at the sash opening of your hood. To determine the actual face velocity at the sash

opening, airflow velocity readings will need to be taken. This should be done across the sash opening of the hood in accordance with the *Industrial Ventilation Manual* section on laboratory hoods. (See Appendix D – Reference) Labconco recommends an average face velocity at the sash opening of 80 to 100 feet per minute. Consult Labconco Customer Service for proper airflow volumes for your particular model.

Your Protector Fume Hood has been tested at the factory per ASHRAE 110-1995. All hoods achieve an “as manufactured rating” of less than 0.10 part per million (ppm) at 4 liters per minute (lpm); AM<0.10 (consult Labconco for individual fume hood ratings). For “field use” ASHRAE testing contact Labconco Ventilation Ventures Team or Customer Service for a certified on-site contractor.



**NOTE: Face velocity profiles and smoke testing should be done periodically to ensure safe performance.**

## Your Next Step

After your Fume Hood has been installed and certified, you are ready to proceed to *Chapter 4: Performance Features and Safety Precautions*.

---

# CHAPTER 4

## PERFORMANCE

## FEATURES AND

## SAFETY

## PRECAUTIONS

### Performance Features:

The Protector® Laboratory Hood is designed to meet the needs of the laboratory scientist. The laboratory fume hood has been designed to effectively contain toxic, noxious, or other harmful materials when properly installed. A fully featured by-pass hood with baffle and air foil, this hood maintains safe airflow. Optional energy saving A-Style Combination Sash models are also available. The hood features by-pass airflow design that allows the hood face velocity to remain relatively stable as the sash is closed. Airflow is diverted behind the front panel and under the air foil to help control fluctuations in face velocity, which occur as the sash is closed.

1. **Unique sash provides maximum visibility of 32.15" high while conserving energy by limiting sash travel to 28"**. Vertical-rising sash may be raised from a closed to 28" operating height. Exhaust volume, and blower sizing is based on the 28" height. Optional sash stops are available to limit sash height and reduce energy usage.
2. **By-pass airflow design** ensures relatively stable face velocities.
3. **Large usable interior work depth and interior height of 48"** provides ample working space.
4. **Baffle** (not shown) directs airflow to the rear of the interior to provide efficient airflow. The baffle may be removed for cleaning purposes only.
5. **Exterior access cover plates** are removable for easy access to plumbing valves when access through the sides is not available.
6. **Lift-Away™ front panel** provides easy access to electrical wiring, sash weights, and lighting fixtures.
7. **Energy efficient fluorescent lighting** is located behind a laminated safety glass shield mounted to the top of the hood. The factory-wired instant start T8 lighting is serviceable from outside the hood cavity.
8. **Low mounted, factory-wired light and blower switches** are ADA compliant.
9. **Clean-Sweep™ Air Foil** allows air to sweep the work surface for maximum containment.
10. **Streamlined corner posts** provide maximum visibility and the flexibility to add services after installation.
11. **All hoods are factory prepared for up to 8 service fixtures.**
12. **Duplex electrical receptacles** are mounted on the right and left corner posts as requested. Receptacles are factory-wired to hood single point junction box.

13. **Shipped fully assembled** and eliminates the need for costly onsite assembly.
14. **Accessory Guardian™ Digital Airflow Monitor or Guardian Jr. Monitor** continuously monitors face velocity. An audio/visual alarm alerts the user to low airflow conditions. The right corner post is factory prepared to accommodate the Guardian Monitor (sold separately).
15. **Optional Energy Reducing A-Style Combination Sash Models.** These combination sashes allow the operator to use the hood with sashes either half open vertically or horizontally to conserve energy. Optional sash stops prevent raising the vertical sash above the half-open, and fully-closed positions unless manually defeated by the operator.
16. **Frame of epoxy-coated steel and aluminum** is durable and corrosion resistant.
17. **Exhaust Connection.** The hood features 12" (12.75" OD pipe) exhaust connections sized to allow for a minimum static pressure loss through the hood structure while providing a good transport velocity through the exhaust system. 4' Integral Blower models use 10" (10.75" OD).
18. **Spillstopper™ Solid Epoxy Work Surface** is dished to contain spills. (Work surface is sold separately).
19. **Optional Ceiling Enclosure Kits** are available for a decorative facade between the hood and the ceiling.
20. **Optional Sash Stops** provide a means of controlling the operating height of the sash.

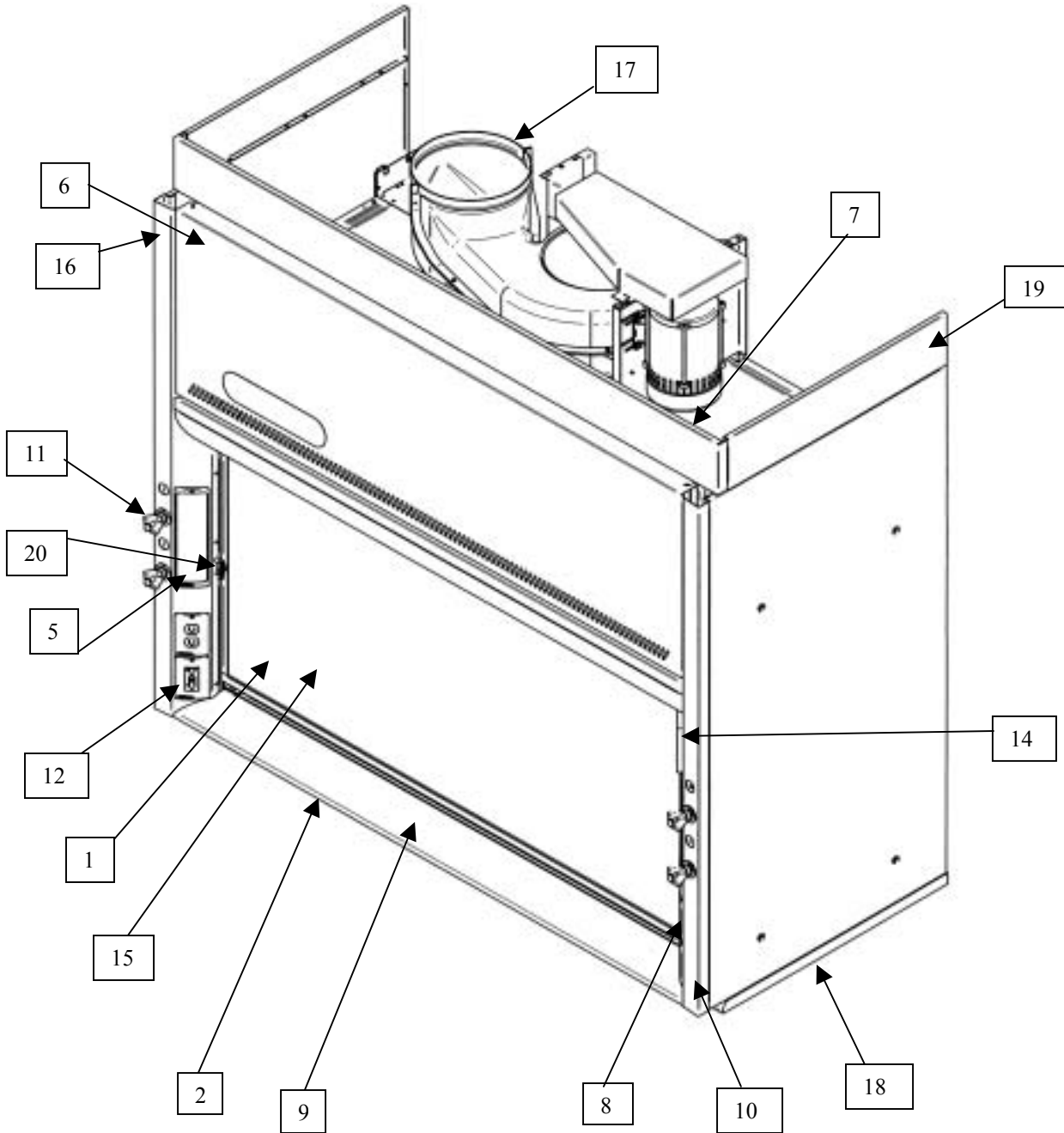

## Safety Precautions



Although the laboratory hood has been engineered to maintain optimum operator safety, caution should always be used while working in the hood. Prior to using the hood, check to make sure that the exhaust blower is operating and that air is entering the hood at its specified face velocity.

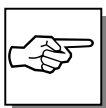

USE GOOD HOUSEKEEPING IN THE HOOD AT ALL TIMES. CLEAN UP SPILLS IMMEDIATELY WITH A MILD DETERGENT. PERIODICALLY CLEAN HOOD INTERIOR, INCLUDING FLUORESCENT LIGHT GLASS PANEL. REPLACE BURNED OUT LIGHT BULBS TO MAINTAIN MAXIMUM ILLUMINATION.

DO NOT OVERLOAD THE WORK SURFACE WITH APPARATUS OR WORK MATERIAL. THE SAFE OPERATION OF THE LABORATORY HOOD IS BASED UPON HAVING PROPER AIRFLOW THROUGH THE STRUCTURE. DO NOT PLACE LARGE, BULKY OBJECTS SUCH AS BLOCK HEATERS, DIRECTLY ON THE HOOD WORK SURFACE. INSTEAD, ELEVATE THE OBJECT 2" TO 3" ON BLOCKS TO ALLOW A FLOW OF AIR UNDER THE OBJECT AND INTO THE LOWER REAR BAFFLE EXHAUST SLOT. ENSURE BLOCKS ARE LEVEL AND SECURED IN PLACE.



**Blocking the bottom of the baffle at rear of hood will change the airflow pattern in the hood causing turbulence and possible leakage at the face of the hood. (Don't store containers or supplies against baffles, as this will affect airflow through the hood).**

**Avoid placing your head inside hood. Keep hands out of hood as much as possible.**

**Always work as far back in hood as possible. It is best to keep all chemicals and apparatus 6" inside the front of the hood.**

**This hood does not feature explosion-proof electrical components, unless ordered separately. Therefore, use of flammable or explosive materials in quantities above the explosive limit are not recommended.**

**Do not work with chemicals in this hood without the exhaust system running. Do not store chemicals in a fume hood.**

**Perchloric acid use in this hood is prohibited.**

**High level radioisotope materials are prohibited for usage in this hood.**

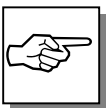

**AVOID CROSS DRAFTS AND LIMIT TRAFFIC IN FRONT OF THE HOOD. AIR DISTURBANCES CREATED MAY DRAW FUMES OUT OF THE HOOD.**



**The use of heat-generating equipment in this hood without the exhaust system operating properly can cause damage to the hood.**

**The Protector Laboratory Hood should be certified by a qualified certification technician before it is initially used. The hood should be re-certified whenever it is relocated, serviced or at least annually thereafter.**

**Ensure that the unit is connected to electrical service in accordance with local and national electrical codes. Failure to do so may create a fire or electrical hazard. Do not remove or service any electrical components without first disconnecting the hood from electrical service.**

**Proper operation of the fume hood depends largely upon the hood's location and the operator's work habits. Consult the *Reference Manual in Appendix D*.**

## **Your Next Step**

After you understand the theory of operation and safety precautions, you are ready to proceed to *Chapter 5: Using Your Protector Fume Hood*.



---

# CHAPTER 5

## USING YOUR PROTECTOR FUME HOOD

### Operating the Vertical- Rising Sash



Because of the Protector Hood counterbalanced sash mechanism, it will take only a few pounds of force to move the sash up or down, and you can operate the sash smoothly with one or two hands positioned anywhere along the handle. The vertical-rising sash may be raised to a maximum 28" operating height. The airflow requirements should be sized for the 28" operating height; if using sash stops then the airflow requirements can be reduced by approximately 40% at 18" or approximately 50% at 15".

**A**

## Operating the A-Style Combination Sash

Optional hood models have additional energy saving sashes called A-Style Combination Sashes in place of vertical-rising sashes. These combination sashes allow the operator to use the hood with sashes either half open horizontally or vertically to conserve energy. The horizontal sashes are used in normal operating mode. Optional sets of sash stops can be installed to prevent raising the vertical sash above the half-open and fully-closed positions unless manually defeated by the operator. The airflow requirements are sized for the 50% open sash condition.

**S**

**A**

## Operating the Blower

Your Protector Fume Hood utilizes a remote style blower, which can be activated by turning the blower switch to “ON.” You can validate the hood performance by watching smoke drawn into the hood face opening.

**S**

**A**

## Operating the Lights

Your Protector Fume Hood utilizes a factory-wired fluorescent light to illuminate the hood interior. Simply turn the light switch to “ON” to operate.

## Working in your Protector Fume Hood

### Planning

- Thoroughly understand procedures and equipment required before beginning work.
- Arrange for minimal disruptions, such as room traffic or entry into the room while the hood is in use.

### Start-up

- Turn on fluorescent light and hood blower.
- Slowly raise the sash.
- Check the baffle air slots for obstructions.
- Allow the hood to operate unobstructed for 5 minutes.
- Wear a long sleeved lab coat and rubber gloves. Use protective eyewear. Wear a protective mask if appropriate.

### Loading Materials and Equipment

- Only load the materials required for the procedure. Do not overload the hood.
- Do not obstruct the front air foil, or rear baffle slots.
- Large objects should not be placed close together and spaced above the work surface to permit airflow to sweep under the equipment.
- After loading the hood, wait one minute to purge airborne contaminants from the work area.

### Work Techniques

- Keep all materials at least 6 inches inside of the sash, and perform all contaminated operations as far to the rear of the work area as possible.
- Segregate all clean and contaminated materials in the work area.
- Avoid using techniques or procedures that disrupt the airflow patterns of the hood.

### **Final Purging**

- Upon completion of work, the hood should be allowed to operate for two to three minutes undisturbed, to purge airborne contaminants from the work area before shutting down blower.

### **Unloading Materials and Equipment**

- Objects in contact with contaminated material should be surface decontaminated before removal from the hood.
- All open trays or containers should be covered before being removed from the hood.

### **Shutdown**

- Turn off the fluorescent light and hood blower, then close the sash.

## **Your Next Step**

After you understand how to operate and work in the fume hood, you are ready to proceed to *Chapter 6: Maintaining Your Protector Fume Hood*.

---

# CHAPTER 6

# MAINTAINING YOUR

# PROTECTOR FUME

# HOOD

Now that you have an understanding of how to work in the fume hood, we will review the suggested maintenance schedule and the common service operations necessary to maintain your fume hood for peak performance.



**Only trained and experienced certification technicians should perform some of the service operations after the fume hood has been properly decontaminated. DO NOT attempt to perform these operations if you are not properly trained. The wrench icon precedes the service operations that require qualified technicians.**

## Routine Maintenance Schedule

### Weekly

- Using ordinary dish soap to clean the surface inside of the fume hood, and the work surface.
- Using an appropriate glass cleaner, clean the sash and all glass surfaces.
- Operate the fume hood blower, noting the airflow velocity through the hood using a source of visible smoke.

### Monthly (or more often as required)



- Determine the actual face velocity through the sash opening of the hood where the average reading should be at the specified velocity. (Use calibrated thermal anemometer or other approved apparatus).
- Using a damp cloth, clean the exterior surfaces of the hood, particularly the front of the hood, to remove any accumulated dust.
- Check all service valves, if so equipped, for proper operation.
- The hood baffles should be checked for blockages behind them to ensure that the hood is maintaining proper airflow.
- All weekly activities.

### Annually



- Replace the fluorescent lamps.
- Have the fume hood recertified by a qualified certification technician. See *Certifying the Protector Fume Hood in Chapter 3*.
- All monthly activities.

### Biannually

- The sash assembly should be checked to ensure proper operation and to make sure there are no signs of abnormal wear on the sash pulleys, cables and clamps.

## Routine Service Operations

### **Front Panel Removal:**

1. Simply lift the front panel up and then away from the hood to provide access to the top.

### **Changing the Fluorescent Lamp:**

1. Turn light switch to “OFF”.
2. Remove the front panel as noted earlier.
3. Reach over the front header of the hood and loosen screws to the light reflector and remove light reflector.
4. Remove the fluorescent lamp by pushing it out of the spring-loaded lamp socket and swinging it out of the other lamp socket.
5. Install the new lamp by reversing the removal procedure.



## Your Next Step

After you understand the maintenance procedures, you are ready to proceed to *Chapter 7: Modifying Your Protector Fume Hood*.



---

# CHAPTER 7

## MODIFYING YOUR PROTECTOR FUME HOOD

There are several ways to modify the fume hood for your individual requirements. These include the addition of work surfaces, service fixtures, air monitor, distillation grids, electrical duplex outlets, ceiling enclosures, and rear panels.

### Installing Work Surfaces

Your Protector Fume Hood requires a work surface to work properly. Contact Labconco Customer Service for ordering information.

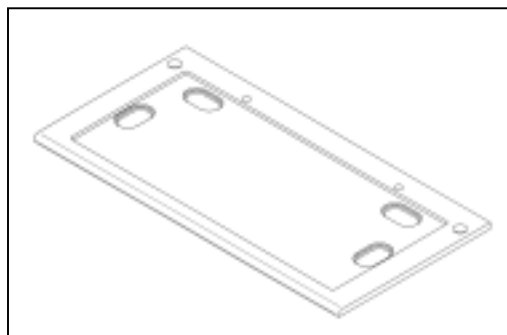
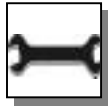

Figure 7-1



## Installing Ceiling Enclosures above the Fume Hood

Your Protector Fume Hood has mounting holes to accept a ceiling enclosure to close off the area between the top of the hood and the ceiling. Contact Labconco Customer Service for ordering information.

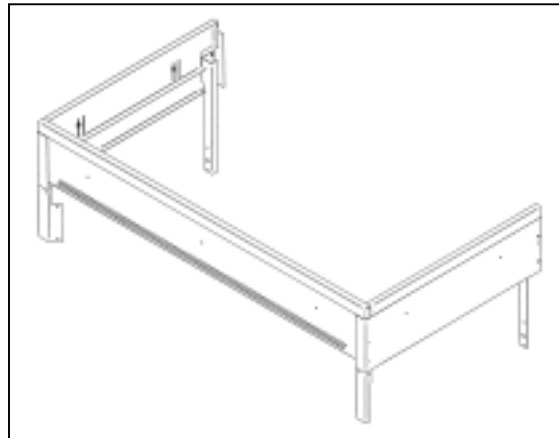

Figure 7-2



## Installing Rear Panels Behind the Fume Hood

Your Protector Fume Hood can be modified to add a rear panel behind the fume hood when the fume hood is placed on an island. Contact Labconco Customer Service for ordering information.

## Installing Additional Service Fixtures



Additional service fixtures can be installed in the available service fixture holes in both sidewalls and corner posts. The fume hood is factory set to accept up to four valves per side. Contact Labconco Customer Service for information.

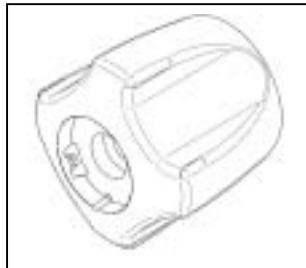

Figure 7-3 - Knob

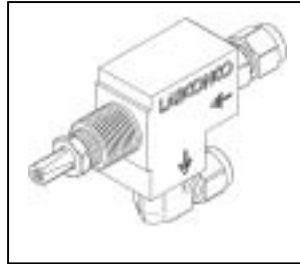

Figure 7-4 - Valve



Figure 7-5 – Hose Connector

## Installing Guardian™ Digital Airflow Monitor or Guardian™ Jr. Airflow Monitor



The Guardian Digital Airflow Monitor P/N 9743201 or Guardian Jr. Airflow Monitor P/N 9743202 allows you to continuously monitor face velocity through the fume hood opening. The fume hood right corner post is factory prepared to mount either monitor. Contact Labconco Customer Service to order.

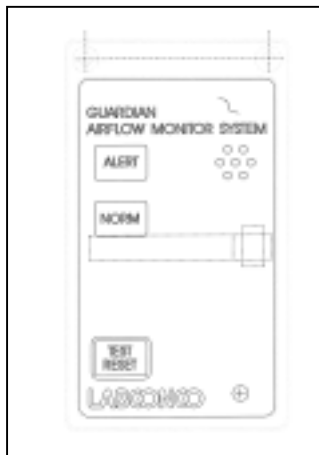

Figure 7-6

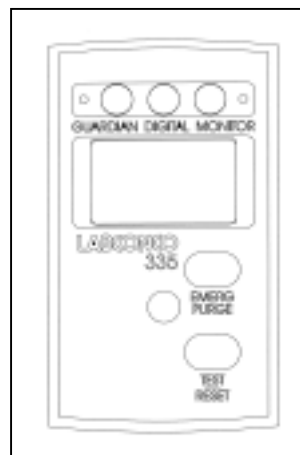

Figure 7-7

## Distillation Grids – Field Installation



The distillation grid P/N's 9725200 thru 9725206, have been strategically placed with the vertical rod center lines in front of the lower baffle and middle baffle. The distillation grids allow the hood user to mount glassware, motors, stirrers, and other apparatus. Contact Labconco Customer Service for ordering information.

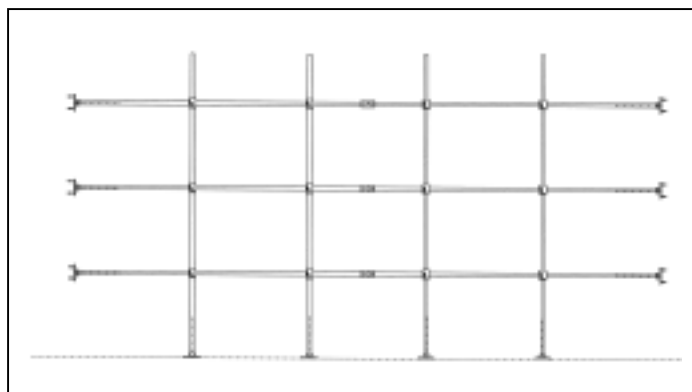

Figure 7-8

## Sash Stop Kit – Field Installation



The sash stop P/N 9724500 restricts how far a vertical-rising sash may be opened. This small plastic device may be easily field installed on the fixture corner post of any fume hood. The metal bracket is simply mounted to the sash handle.

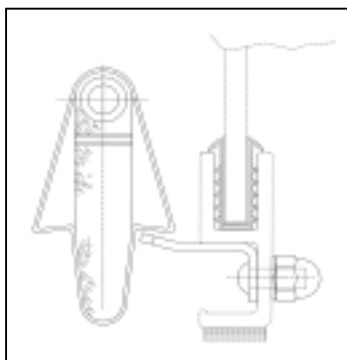

Figure 7-9

## Installing an Electrical Duplex Outlet

Your Protector Fume Hood can be ordered with duplex outlets, however, if you ordered a model without an electrical duplex outlet you can have one installed in the field by a qualified electrician. Contact Labconco Customer Service for ordering information. (Not acceptable on explosion-proof hoods).

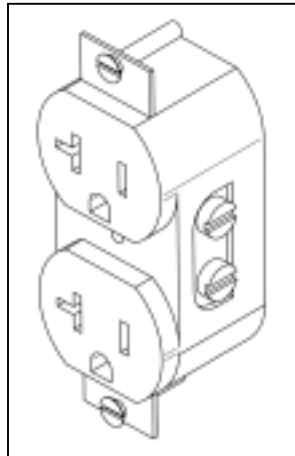

Figure 7-10

## Your Next Step

After you understand the modifying procedures, you are ready to proceed to *Chapter 8: Troubleshooting*.



---

# CHAPTER 8

## TROUBLESHOOTING

Refer to the following table if your fume hood fails to operate properly. If the suggested corrective actions do not solve your problem, contact Labconco for additional assistance.

PROBLEM	CAUSE	CORRECTIVE ACTION
<b>Remote blower and lights won't operate</b>	Wires not connected at junction boxes or switches.	Check connection of switches.
		Check connection to control box on top of unit.
	Circuit breakers tripped in building electrical supply.	Reset circuit breakers.
<b>Remote blower won't operate, but lights work</b>	Blower wiring is disconnected.	Inspect blower wiring and switch.
	Belt broken	Replace belt.
	Blower motor is defective.	Replace blower motor.
<b>Fume hood blower operates but lights will not operate</b>	Lamp not installed correctly.	Inspect lamp installation.
	Lamp is defective.	Replace lamp.
	Lamp circuit breaker in building is tripped.	Reset the lamp circuit breaker.

<b>PROBLEM</b>	<b>CAUSE</b>	<b>CORRECTIVE ACTION</b>
<b>Fume hood blower operates but lights will not operate</b>	Lamp wiring is disconnected.	Inspect lamp wiring.
	Defective lamp ballasts.	Replace lamp ballasts.
<b>Contaminants outside of fume hood</b>	Improper user techniques for the fume hood.	See “Certifying the Hood” Chapter 3 and “Safety Precautions” Chapter 4 sections in the manual. (Ref. Appendix D)
	Restriction of the baffle air slots or – blockage of the exhaust outlet.	Remove baffles to ensure that all air slots, and the exhaust outlet are unobstructed.
	External factors are disrupting the fume hood airflow patterns or acting as a source of contamination.	See “Location Requirements” Chapter 2, “Certifying the Hood” Chapter 3, and “Safety Precautions” Chapter 4 sections of this manual. (Ref. Appendix D)
	Fume hood has improper face velocity.	Have fume hood re-certified and check remote blower exhaust system. Hood should have average face velocity of 80-100 fpm.
<b>Vertical sash no longer operates smoothly</b>	Cable is frayed or plastic protection is damaged.	Inspect cable and replace cable if worn or damaged immediately; otherwise injury could result.
	Pulley bearing is damaged.	Replace pulley, bearing or add grease.
	Cable has slipped off the pulleys.	Re-install, cable must be replaced immediately if damaged.
	Weight has broken pulleys.	Replace weight pulleys.
<b>Combination A-Style sash no longer operates smoothly</b>	Horizontal glass panels have come off the tracks.	Re-install horizontal glass on tracks.

<b>PROBLEM</b>	<b>CAUSE</b>	<b>CORRECTIVE ACTION</b>
	Vertical sash frame is distorted.	Place horizontal glass symmetrically and pull sash down to air foil. Straighten damaged frame.
	Cable is frayed or has slipped off the pulleys.	Re-install, cable must be replaced immediately if damaged.
<b>Electrical duplex outlets no longer have power</b>	Wires not connected or faulty duplex.	Check wire connection or replace duplex.
	Circuit breakers tripped in building electrical supply.	Reset circuit breakers.
<b>Service valves no longer operate</b>	Faulty building supply.	Inspect building supply shut off valves and appropriate pressures below 40 PSI.
	Valve no longer operates.	Replace valve and check for leaks.
	Supply line or outlet line has leaks.	Inspect line for leaks and fix any leaking plumbing connections.



---

# APPENDIX A

## PROTECTOR

### COMPONENTS

Illustration A-1 indicate the location of the following service parts:

### Protector Replacement Parts

Item	Quantity	Part No.	Description
1A	1	9817000	Valve, Labconco ¼" Compression Fitting
1B	1	9817001	Valve, Labconco 3/8" Compression Fitting
1C	1	9817002	Valve, Labconco Deionized ¼" Compression Fitting
1D	1	9817003	Valve, Labconco Deionized 3/8" Compression Fitting
1E	1	9818000	Nut, Valve Mounting. (Labconco)
2A	1	9826800	WaterSaver Valve/Gooseneck -GRN
2B	1	9826801	WaterSaver Valve/Connector (VAC) – YEL
2C	1	9826802	WaterSaver Valve/Connector (AIR) – ORG
2D	1	9826803	WaterSaver Valve/Connector (GAS) – BLU
2E	1	9826805	WaterSaver Valve/Connector (HOT WATER) – RED
2F	1	9826806	WaterSaver Valve/Connector (CW) – GRN
2G	1	9826807	WaterSaver Valve/Connector (STEAM) – BLK
2H	1	9826808	WaterSaver Valve/Connector (NITROGEN) – BRN
2I	1	9826809	WaterSaver Valve/Connector (OXYGEN) – LIGHT GREEN
2J	1	9826810	Swivel Gooseneck only – GRN
2K	1	9826812	Swivel Gooseneck only – WHITE
3	1	9818700 thru 08	Knobs (GRAY, GRN, BLU, ORG, YEL, RED, WHT, BLK, BRN)
4A	1	9818800	Hose Barb, GRAY – (NEUTRAL OR ARGON)-NOT SHOWN
4B	1	9818801	Hose Barb, GREEN - (COLD WATER)-NOT SHOWN
4C	1	9818802	Hose Barb, BLUE – (GAS)-NOT SHOWN
4D	1	9818803	Hose Barb, ORANGE – (AIR)-NOT SHOWN
4E	1	9818804	Hose Barb, YELLOW – (VACUUM)-NOT SHOWN
4F	1	9818805	Hose Barb, RED – (HOT WATER)-NOT SHOWN
4G	1	9818806	Hose Barb, WHITE – (DEIONIZED WATER) NOT SHOWN
4H	1	9818807	Hose Barb, BLACK–(NEUTRAL OR STEAM) NOT SHOWN
4I	1	9818808	Hose Barb, BROWN – (NITROGEN) NOT SHOWN

## Appendix A: Protector Components

Item	Quantity	Part No.	Description
4J	1	9819000	Nut, Hose Barb - NOT SHOWN
5	1	9825500	Label, Knob (contains all the labels)
6	1	9818900	Lens, Knob
7A	1	9826600, 01, 02	115V Duplex Receptacle (GRAY) Right, Left 4' - 6', Left 8' w/ wires
7B	1	9818200	Cover Plate 115V Duplex
7C	1	9826603, 04, 05	115V GFCI Duplex Receptacle (GRAY) Right, 4' - 6', Left 8' w/ wires
7D	1	9818100	Cover Plate, 115V GFCI
7E	1	9818300	Cover Plate, Blank
8A	1	9721901	Lamp, Fluorescent (T8 x 3') – use on 4' & 8' Hoods-NOT SHOWN
8B	1	9721900	Lamp, Fluorescent (T8 x 4') – use on 5' & 6' Hoods-NOT SHOWN
9	1	9826900	Ballast Assy (used on T8 Slimline) – NOT SHOWN
10A	1	1302300	Switch, Rocker
10B	1	1327500	Switch, Plug (Fills cutout when switch is not used)
11A	1	9818400	Access Cover
11B	1	9825100	Label, Access Cover (includes all three corner labels)
12A	1	9810800	Side Panel, 24" internal deep hoods
12B	1	9810801	Side Panel, 30" internal deep hoods
12C	1	9810802	Side Panel, 36" internal deep hoods
12D	4	1916400	Nut, Retainer #10-24
12E	4	1885512	Screw, Machine #10-24 x .75 Truss Head Stainless
13A	1	9824200	Air Foil 4'
13B	1	9824201	Air Foil 5'
13C	1	9824202	Air Foil 6'
13D	1	9824203	Air Foil 8'
14	4	1861400	Pulley, Front or Rear, 1-3/16 Dia. (rear of 4', 5', 6' only)
15	2	4949902	Cable, Sash 130" – NOT SHOWN
16	2	9741900	Sheave, (Rear 8')
17	2	1663200	Bumper, Rubber – NOT SHOWN (upper sash bumper)
18	4	9742100	Bronze Bearing, Flanged Rear – NOT SHOWN
19	4	1920100	Clamp, Cable Replacement – NOT SHOWN
20	2	1972100	S-Hook – NOT SHOWN (to attach weight to cable)
21A	1	9826300	Wiring Harness, Main
21B	1	9826400	Wiring Harness, Ballast 115V, 4' - 6'
21C	1	9826700	Wiring Harness, Ballast 115V, 8'
22A	1	9807600, 01, 02, 03	Front Panel, 4', 5', 6', 8'
22B	1	9870700, 01, 02, 03, 04, 05	Panel Assembly Front 10'L, 10'R, 12'L, 12'R, 16'L, 16'R
23	1	1859900	Belt-V 3L380
24A	1	1209400	Motor, 1/3 HP 4' 115V
24B	1	1209500	Motor, 1/2 HP 5' & 6' 115V
24C	1	1206600	Motor, 1/3 HP EP 4' 115V/230V
24D	1	1208200	Motor, 1/2 HP EP 5' & 6' 115V/230V
24E	1	1202400	Motor, 1/2 HP 230V
25	1	4862900	Wheel, Blower
26	1	4863400	Shaft, Blower
27	2	1863000	Bearing, Pillow Block
28A	1	9778900	Front Panel Extension 4'
28B	1	9778901	Front Panel Extension 5'
28C	1	9778902	Front Panel Extension 6'
29	1	9779000	Side Panel Extension
30	1	9724500	Sash Stop Kit
31	1	1663200	Upper Sash Bumper

Figure A-1

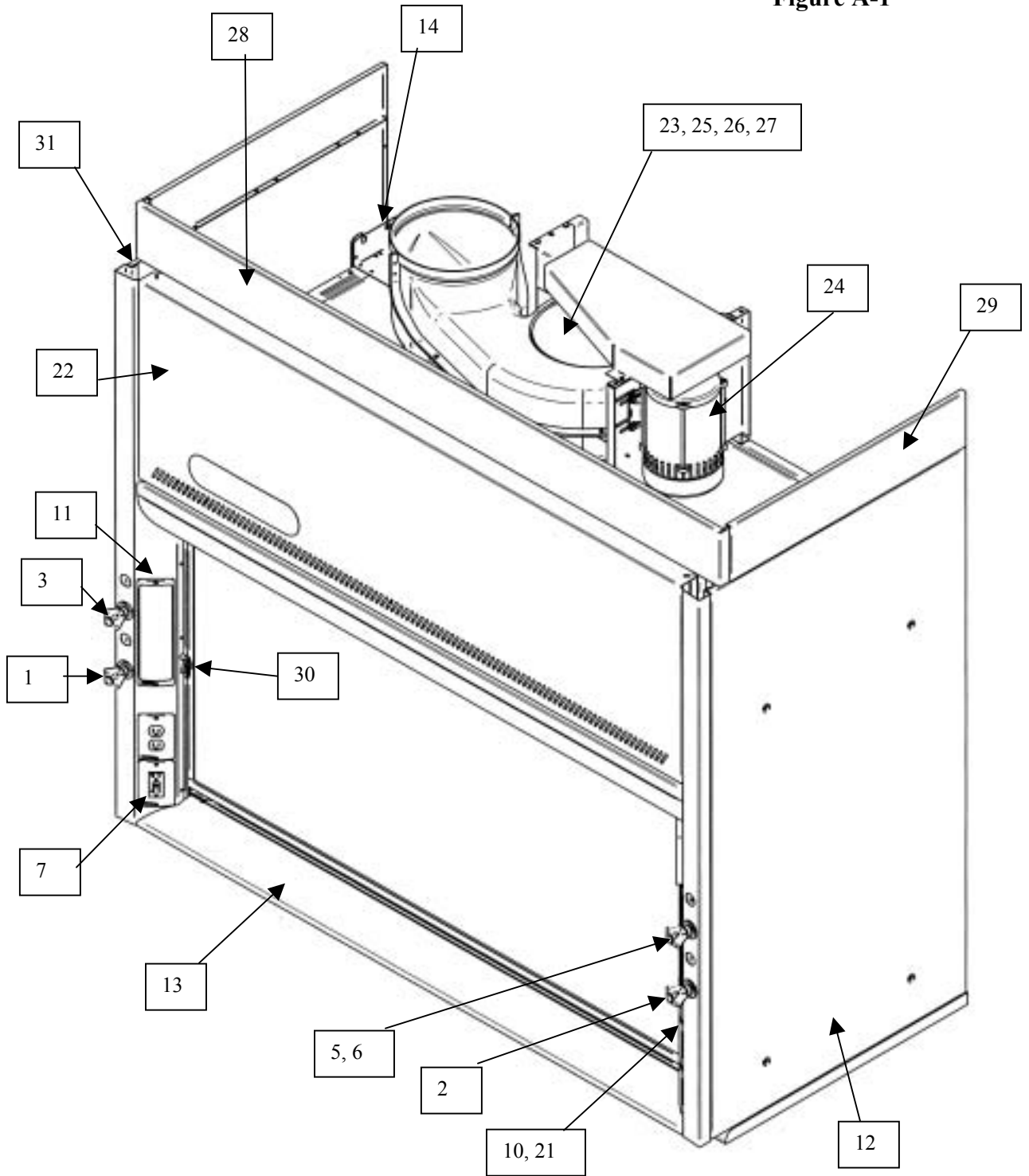



# APPENDIX B PROTECTOR DIMENSIONS

Premier® Model Widths

	4'	5'	6'	8'
A	48.00	60.00	72.00	96.00
B	38.25	50.25	62.25	86.25

Dimensions in inches. CAD layouts available upon request.

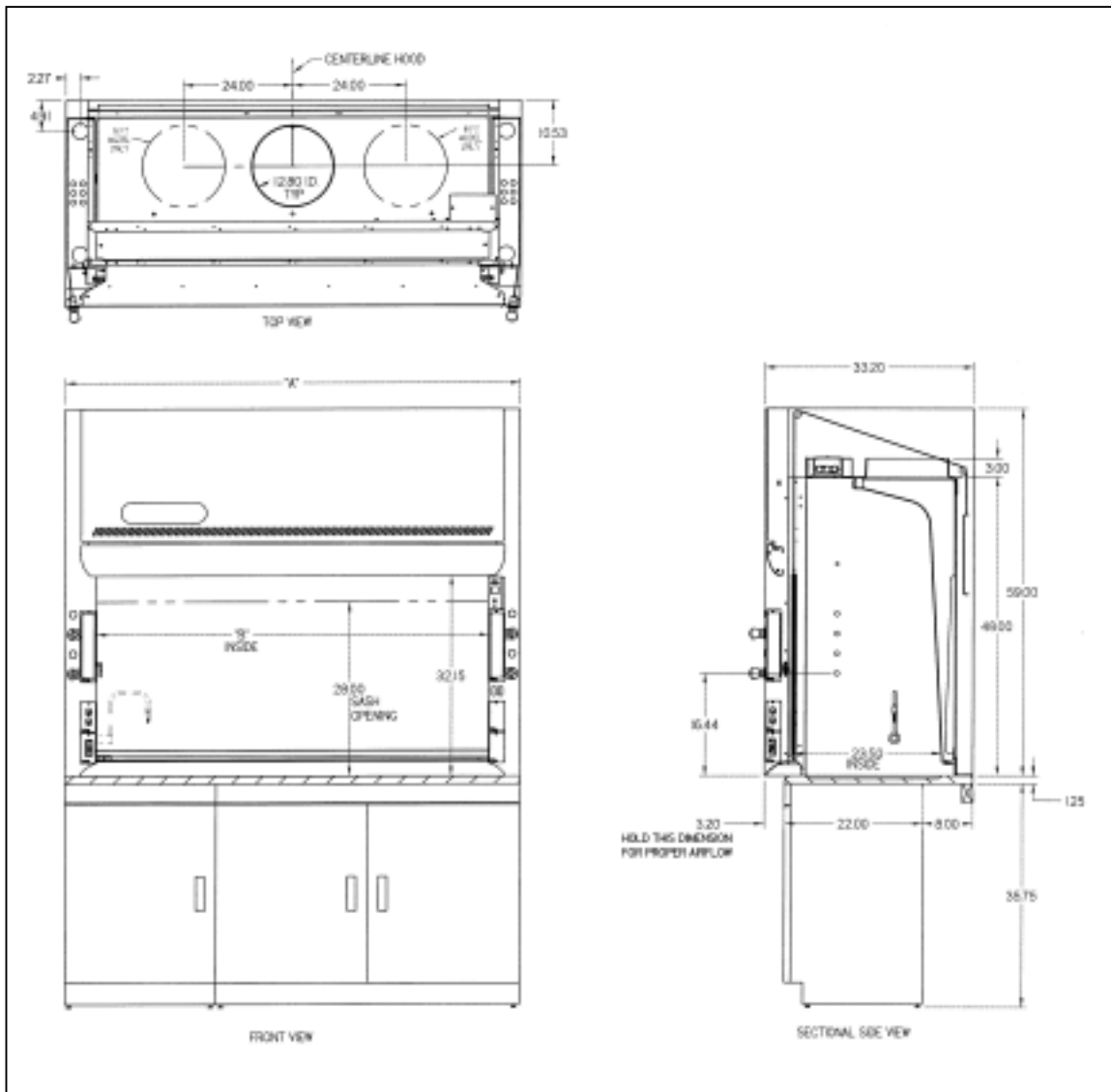

Figure B-1

**Premier Integral Model Widths**

	4'	5'	6'
A	48.00	60.00	72.00
B	38.25	50.25	62.25

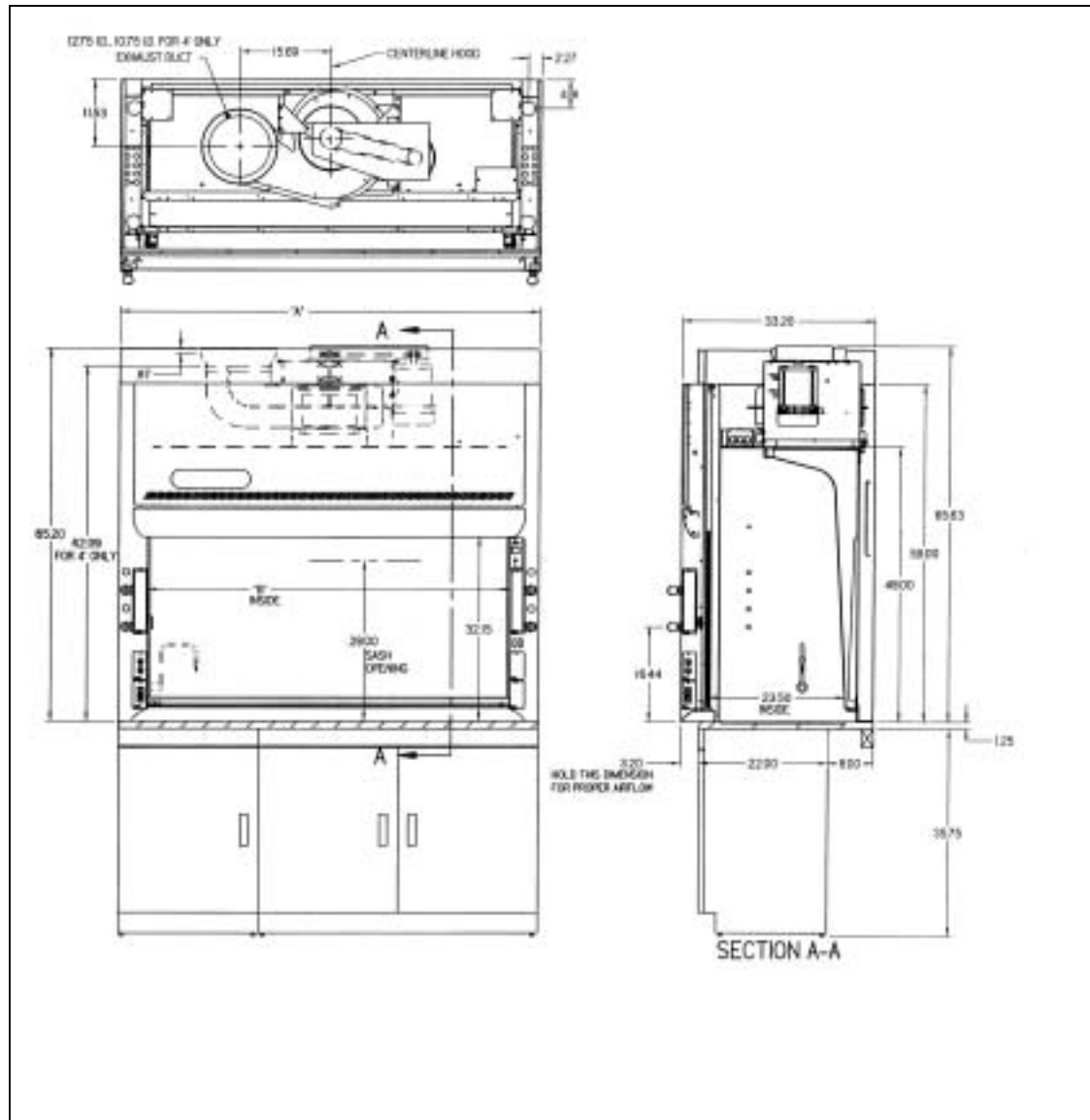

Figure B-2





---

# APPENDIX C

# PROTECTOR FUME

# HOOD

# SPECIFICATIONS

## Environmental Conditions

- Indoor use only.
- Maximum altitude: 6562 feet (2000 meters).
- Ambient temperature range: 41° to 104°F (5° to 40°C).
- Maximum relative humidity: 80% for temperatures up to 88°F (31°C), decreasing linearly to 50% relative humidity at 104°F (40°C).
- Main supply voltage fluctuations not to exceed  $\pm 10\%$  of the nominal voltage.
- Transient over-voltages according to Installation Categories II (Over-voltage Categories per IEC 1010). Temporary voltage spikes on the AC input line that may be as high as 1500V for 115V models and 2500V for 230V models are allowed.
- Used in an environment of Pollution degrees 2 (i.e., where normally only non-conductive atmospheres are present). Occasionally, however, a temporary conductivity caused by condensation must be expected, in accordance with IEC 664.

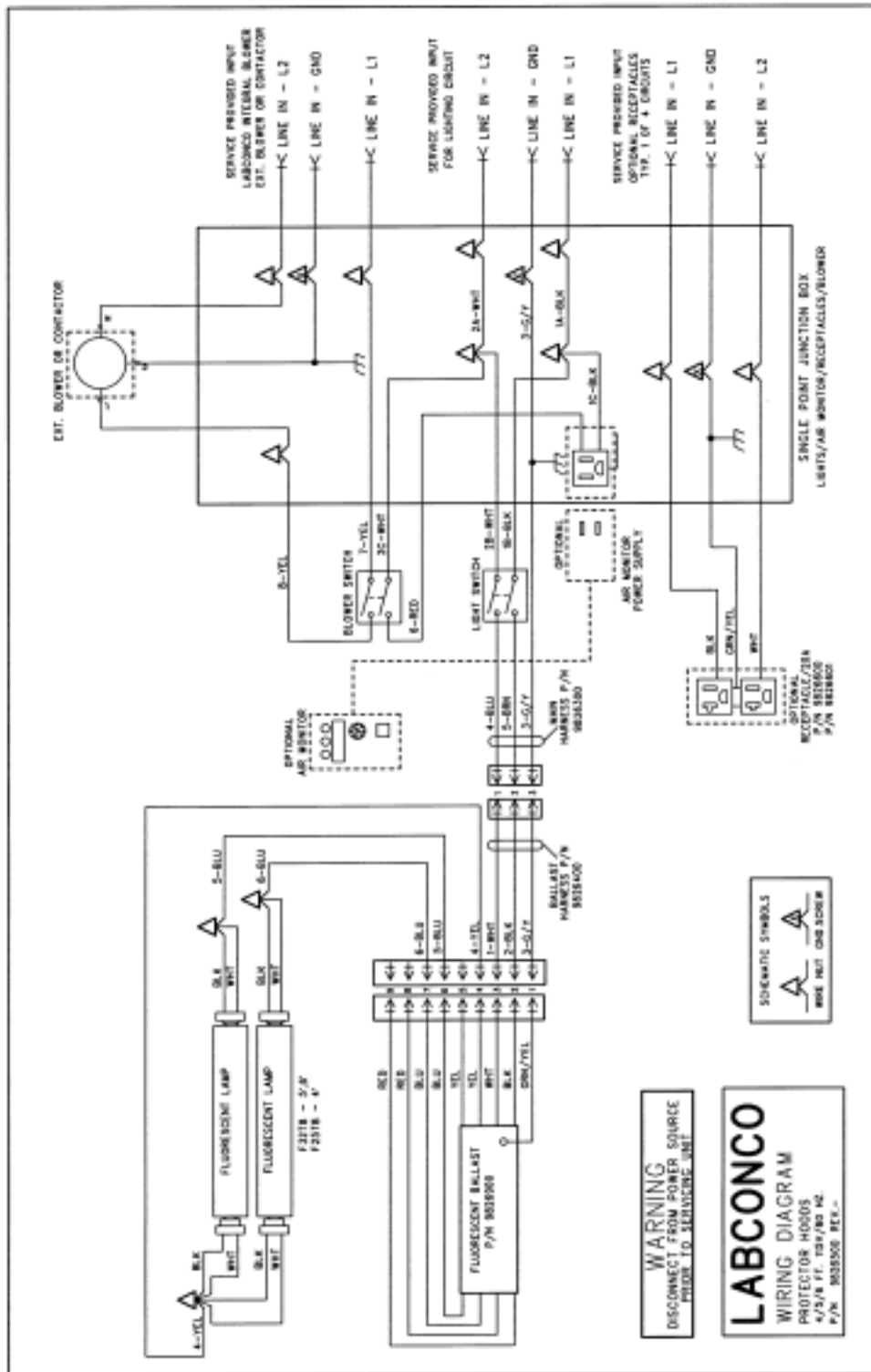

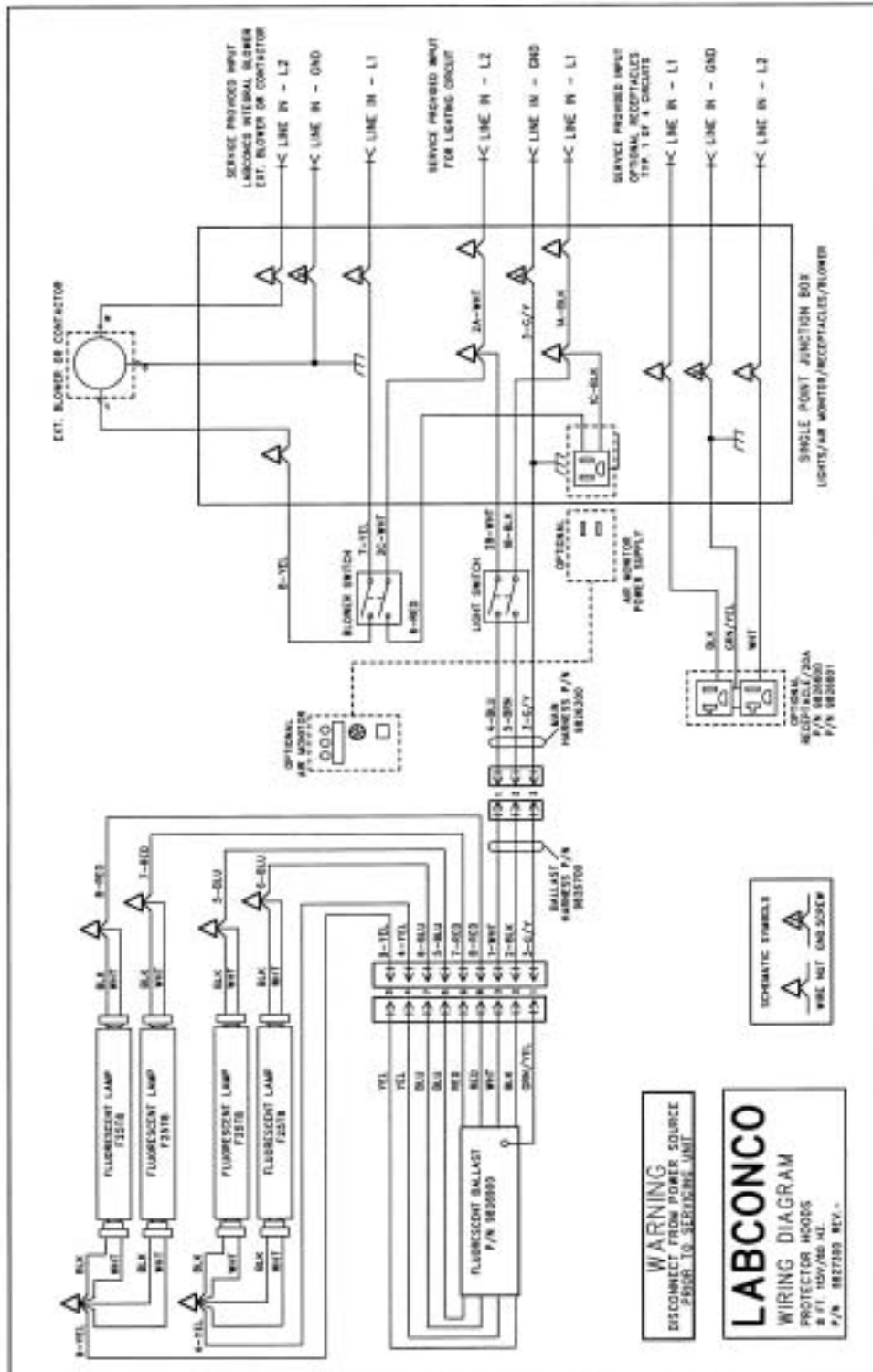

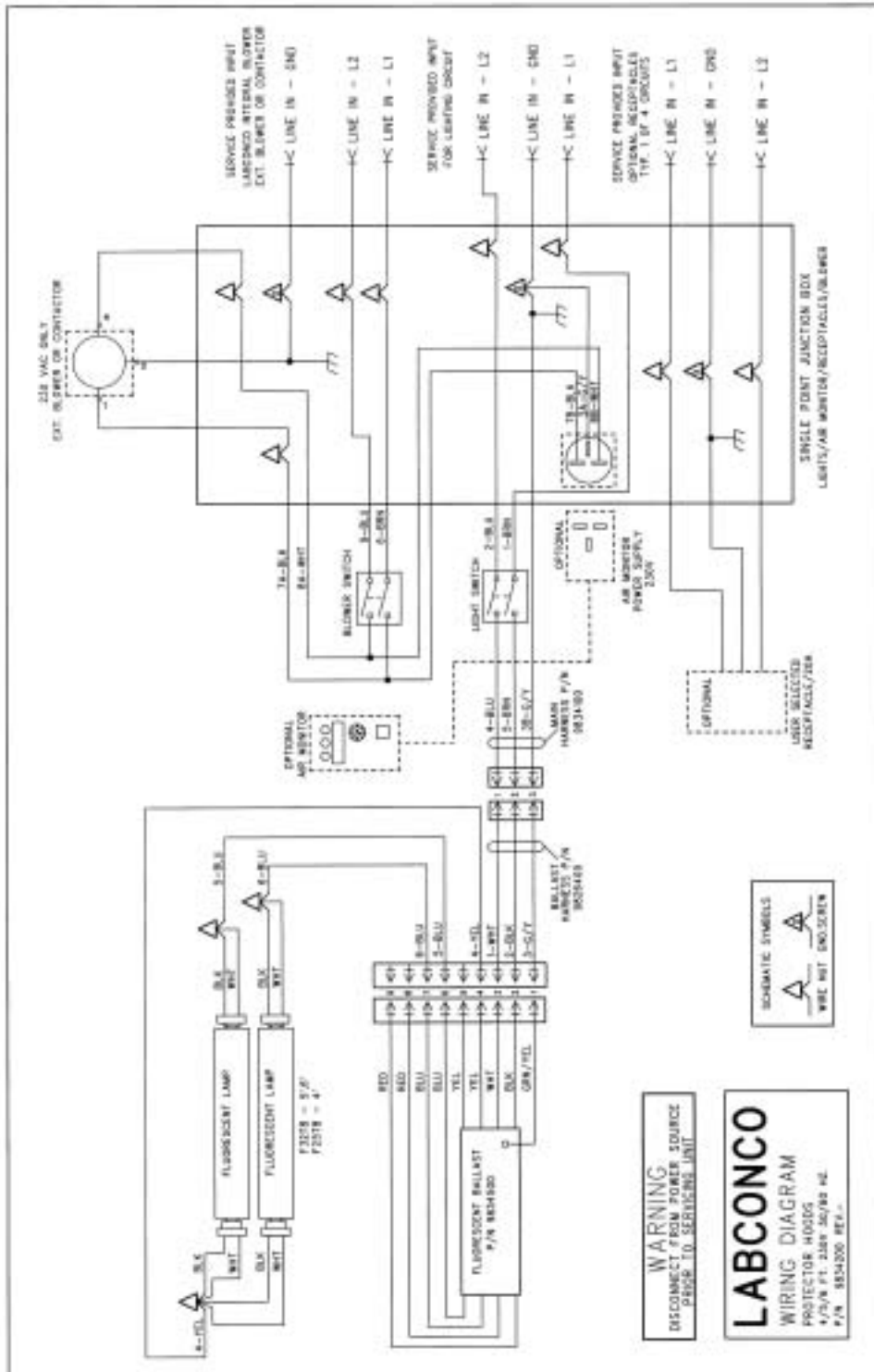

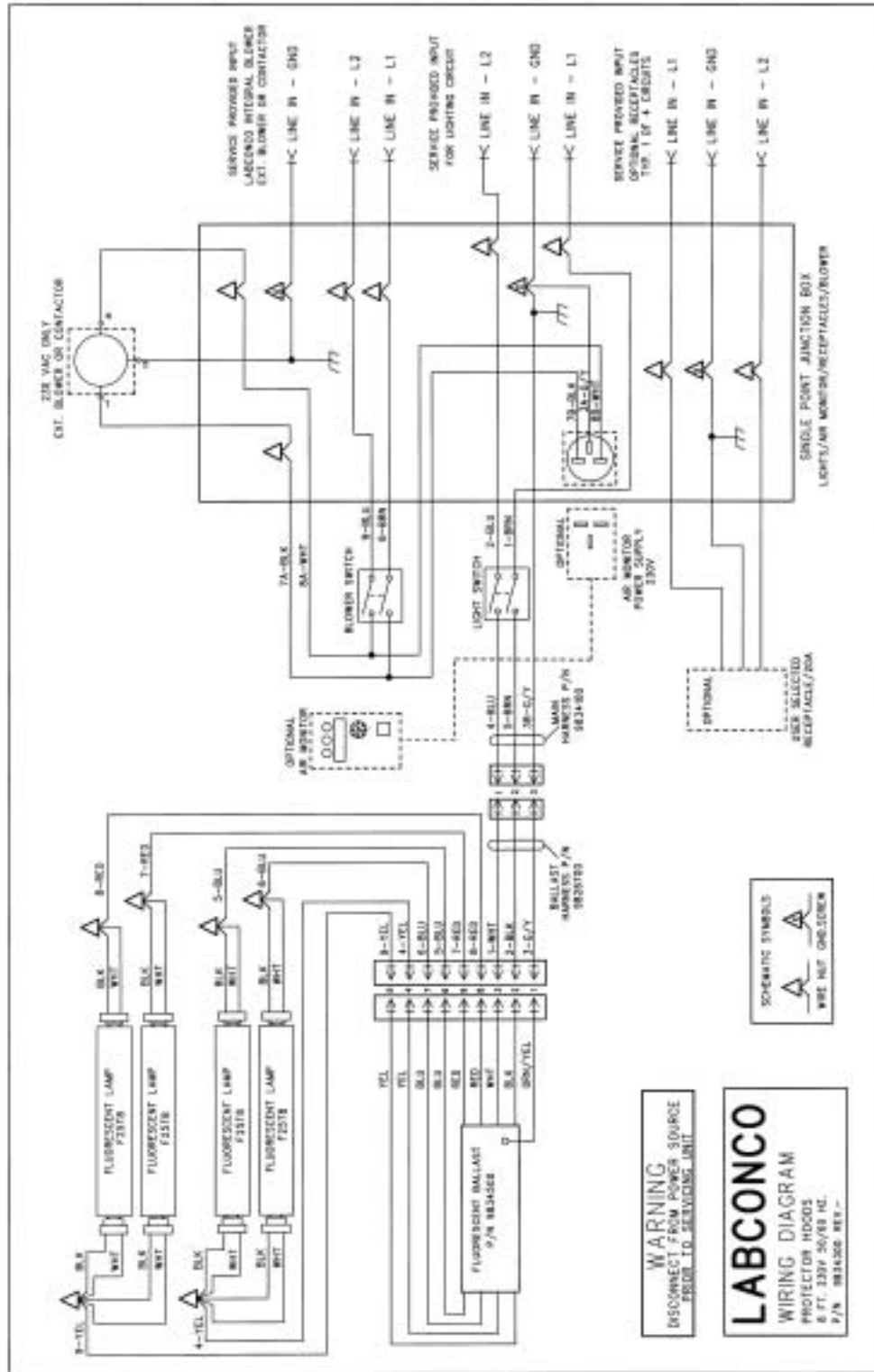



---

# APPENDIX D

## REFERENCES

Many excellent reference texts and booklets are currently available. The following is a brief listing:

### Laboratory Ventilation Standards

#### Federal Register 29 CFR Part 1910

*Non-mandatory recommendations from "Prudent Practices".*

- Fume hoods should have a continuous monitoring device
- Face velocities should be between 60-100 linear feet per minute (lfpm)
- Average 2.5 linear feet of hood space per person

#### Occupational Health and Safety

U.S. Department of Labor

200 Constitution Avenue N.W.

Washington, DC 20210

(202) 523-1452

#### Industrial Ventilation-ACGIH

- Fume hood face velocities between 60-100 lfpm
- Maximum of 125 lfpm for radioisotope hoods
- Duct velocities of 1000-2000 fpm for vapors, gasses and smoke
- Stack discharge height 1.3-2.0 x building height
- Well designed fume hood containment loss, <0.10 ppm

*Industrial Ventilation, A Manual of Recommended Practice.*

24<sup>th</sup> Edition, 2001

American Conference of Governmental Industrial Hygienists

1330 Kemper Meadow drive

Cincinnati, OH 45240-1634

(513) 742-2020

**ASHRAE 110-1995 Method of Testing Performance of Fume Hoods**

*Evaluates fume hood's containment characteristics*

- Three part test: Smoke generation, Face velocity profile, Tracer gas release @ 4 liters per minute
- Rated As Manufactured (AM), As Installed (AI) and As Used (AU)

**American Society of Heating, Refrigerating, and Air Conditioning Engineers**

**1791 Tullie Circle N.E.**

**Atlanta, GA 30329**

**(404) 636-8400**

**ANSI Z9.5-1993 Laboratory Standard**

*Covers entire laboratory ventilation system.*

- Vertical stack discharge @ 2000-3000 fpm
- New and remodeled hoods shall have a monitoring device
- Ductless hoods should only be used with non-hazardous materials
- Fume hood face velocities between 80-120 fpm

**American Industrial Hygiene Association**

**2700 Prosperity Avenue, Suite 250**

**Fairfax, VA 22031**

**(703) 849-8888**

**SEFA 1-2002**

- Fume hood face velocities based on toxicity levels of chemicals
  - Class A – 125 to 150 fpm
  - Class B – 80 to 100 fpm
  - Class C – 75 to 80 fpm
- Test method – face velocity profile and smoke generation

**Scientific Equipment & Furniture Association**

**1028 Duchess Drive**

**McLean, VA 22102**

**(703) 538-6007**

**NFPA 45 – 2002 Fire Protection for Laboratories Using Chemicals**

- Laboratory hoods should not be relied on for explosion protection
- Exhaust air from fume hoods should not be recirculated
- Services should be external to the hood
- Canopy hoods only for non-hazardous applications
- Materials of construction should have flame spread of 25 or less
- 80 to 120 fpm to prevent escape

**NFPA 30 – 2000 Flammable and Combustible Liquids Code**

- Approved cabinets may be metal or wood
- Vent location on cabinets are required
- Venting of cabinets not a requirement

**National Fire Protection Association**  
**1 Batterymarch Park**  
**P.O. Box 9101**  
**Quincy, MA 02269-9101**  
**(800) 344-3555**

**General References**

American Conference of Governmental Industrial Hygienists. *Industrial Ventilation, A Manual of Recommended Practice*, Cincinnati, OH

ASHRAE Standard Committee. *ASHRAE Standard Atlanta*: ASHRAE Publications Sales Department, 1995

British Standards Institution, *Laboratory Fume Cupboards*. Parts 1, 2 and 3, London: 1990

Department of Labor, Occupational Safety and Health Administration, *29 CFR Part 1910, Occupational Exposures to Hazardous Chemicals in Laboratories, Final Rule*. Vol. 55, No. 21. Washington D.C.:1990

DiBerardinis. L. et al. *Guides for Laboratory Design, Health and Safety Considerations*. Wiley & Sons, 1987

McDermott, Henry, *Handbook of Ventilation for Contaminant Control, 2<sup>nd</sup> Edition*. Butterworth Publishers, 1985.

Miller, Brinton M. et al. *Laboratory Safety: Principles and Practices*. American Society for Microbiology, Washington, D.C.: 1986

*NIH Guidelines for the Laboratory Use of Chemical Carcinogens*. NIH Publication No. 81-2385.

Rayburn, Stephen R. *The Foundation of Laboratory Safety, A Guide for the Biomedical Laboratory*. Springer-Verlag, New York: 1990

Sax, N. Irving and Lewis, JR., Richard J. *Rapid Guide to Hazardous Chemicals in the Workplace*. Van Nostrand Reinhold, 1987.

---

---

*Appendix D: References*

---

---

Schilt, Alfred A. *Perchloric Acid and Perchlorates*. The G. Frederick Smith Chemical Company, Columbus, OH: 1979.

Steere, Norman. *CRC Handbook of Laboratory Safety, 2<sup>nd</sup> Edition*. CRC Press, 1971.

---

# APPENDIX E

## DISASSEMBLY AND REASSEMBLY

### INSTRUCTIONS – XL

#### STYLE HOODS

#### **Required Tools**

The following tools will be required for disassembly and reassembly:

Cordless Drills and Phillips bits.

1/4", 5/16", 3/8", 7/16" Sockets

Small Screwdriver

Phillips Screwdriver

Right Angle Screwdriver

1/4", 5/16" Box Ratchet

1/4" Extension

5/16", 3/8", 7/16" Combination Wrench

1/4" Ratchet

Small Right Angle Needle Nose Pliers

Nut Driver Set

#### **Decorative Panel Removal**

1. Remove side panels by removing #10-24 screws and lifting away.
2. Remove front panels by lifting up and away.

#### **Light Removal and Blower Wiring**

1. On the top of the hood, disconnect the Molex connector and remove the green ground wire. All the removable wires are part of the wiring harness to the corner post switches. Be sure to label all wires and refer to the wiring diagrams for proper reassembly.

### **Header Removal**

1. The header is fastened to the corner posts by four #12 screws. Simply reach behind the corner posts from the side and remove the screws while another person supports the header.

### **Sash Removal**

There is one sash to be removed on the 4', 5', and 6' hoods. Please note that there are two sashes that need to be removed for the 8', 10', and 12' hoods and four sashes on the 16' hood. Please repeat the procedure for each sash.

1. For 8' through 16', remove the bumper from the middle sash slide by removing the screw. Be careful not to misplace the loose parts. This part is a crucial component to the operation of the sash.
2. For 8' through 16', remove the middle sash slide assemblies by sliding them up and out.
3. Remove the sash end stops by removing the hardware.
4. Remove end cable and pulleys from sides.
5. Now the glass sash assembly can be removed by sliding it up and out.
6. Remove sash weights. The weights were shipped attached to the back.

### **Top Assembly Removal**

Please note that the 4' through 8' hoods are designed with one continuous top liner. Therefore, the top support is not required for the 4' through 8' hoods, but is used on the 10', 12', and 16' hoods.

1. Remove the top support by removing the 1/4 –20 hardware and screws.
2. Remove the anti-rack shaft assemblies by removing the screws.
3. Then remove the top liner assemblies by removing the screws.

### **Front Truss Removal**

1. Remove the front truss support from the side frames by removing the 1/4 –20 x 1.5" hex head screws, washers, lockwashers, and nuts. Simply reach behind the side frames while somebody supports the front truss and remove it.

### **Airfoil Removal**

1. Remove lower corner post screw located under the airfoil.
2. Remove the airfoil by removing the rear screws located on top of the airfoil on each side.

### **Rear Frame Removal**

1. Remove the rear frames from the side frames by removing screws from each side frame.
2. If desired, you can remove the right rear frame from the left rear frame by removing the 1/4-20 hardware, angle support, and screws. This step is not always necessary and depends on the installation and size of the hoods.

### **Transport and Reassembly**

The various subassemblies are now ready to be transported and reassembled in the opposite way the hood was disassembled. All hoods will require a minimum of five people to lift the hood, two people on each side and one in front (for balance only). A hydraulic lift table should be used as an aid in lifting. The 16' hood should be assembled where placed. If in doubt about lifting the hood, always reassemble the hood where it will be placed.

### **Reinstallation**

Make sure the anti-rack shaft does not slide from left to right as this will be noisy and not work effectively.

### **Sash Weight Reassembly**

After the hood is assembled, the sash weights are easily installed before the hood is placed against a rear wall. **Please keep this in mind and install the sash weights now.**

### **Baffles Installation**

Install the upper baffle, middle baffle, and lower baffle. Be sure the baffles are resting in the proper baffle mount supports.

### **Hood Replacement and Service Installation**

The hood is now ready for placement and the HVAC, plumbing and electrical service can be installed.

### DECLARATION OF CONFORMITY

Application Council Directive(s): 73/23/EEC, 89/336/EEC

Standard(s) to which conformity is declared: EN61010, EN55022, EN50082-1

Manufacturer's Name: Labconco Corporation

Manufacturer's Address: 8811 Prospect Avenue  
Kansas City, MO 64132 USA

Importer's Name: See Shipping/Customs Documents\*

Importer's Address: See Shipping/Customs Documents for your equipment

Type of Equipment: Laboratory Equipment Protector Laboratory Hoods

Premier Model No.: 48700 Series thru 48800 Series 4' Protector Laboratory Hoods  
60700 Series thru 60800 Series 5' Protector Laboratory Hoods  
72700 Series thru 72800 Series 6' Protector Laboratory Hoods  
9674500, 9683000 8' Protector Laboratory Hoods  
XL Models 97001 Series thru 97004 Series Protector Laboratory Hoods  
97504 Series thru 97506 Series Protector Laboratory Hoods  
97001, 97002, 97003, 97004 Series Protector Laboratory Hoods

Serial No.: Various – See Individual Declaration

Year of Manufacture: 2002 and subsequent

I, the undersigned, hereby declare that the equipment specified above conforms to the above Directive(s) and Standard(s).

See individual Declaration of Conformity which will be signed by the importer for your country.

Place: \_\_\_\_\_  
(Signature)

Date: \_\_\_\_\_  
(Full Name)

\_\_\_\_\_  
(Position)

\*An individual version of this declaration is included with your shipping/customs documentation.

For more information, please contact us:

ExpotechUSA  
10700 Rockley Road  
Houston, Texas 77099  
USA

281-496-0900 [voice]

281-496-0400 [fax]

E-mail: sales@expotechusa.com

Website: www.ExpotechUSA.com