

WaterPro[®] PS Station

Models

9000500, 9000501, 9000502, 9000503
9000600, 9000601, 9000602, 9000603
9000700, 9000701, 9000702, 9000703
9000704, 9000705

INSTRUCTION MANUAL

Product designs are subject to change without notice

90496 Rev. I / ECO B053
Printed in U.S.A.

For more information, please contact us:

ExpotechUSA

10700 Rockley Road
Houston, Texas 77099
USA

281-496-0900 [voice]

281-496-0400 [fax]

E-mail: sales@expotechusa.com

Website: www.ExpotechUSA.com

TABLE OF CONTENTS

Introduction	
Components Shipped	1
General Description	2
Flow Diagrams	3
Component Identification	8
Specifications	10
Installation	
Preparation	13
Inspection	13
Installation	13
Electrical Connection	13
Feedwater Quality	13
Feedwater Connection	14
Tubing Installation	14
Drain Connections	15
Safety Precautions	16
Normal Operation	
Initial Operation and Cartridge Installation	17
Electronic Control	19
Automatic Intermittent Recirculation	20
Ultrafilter Flush Valve Operation	20
TOC Dump Valve Operation	20
UV Lamp Replacement	21
Cartridge Replacement	21
Replacement of Optional Final Filter	21
Replacement of Ultrafilter	22
Maintenance	
System Sanitization	23
Replacement Parts	24
Wiring Diagrams	26
Dimensional Drawing	28
Troubleshooting	29
Accessories	32
Warranty	33

TABLE OF CONTENTS

Shipping Claims	34
Contacting Labconco	35
Declaration of Conformity	36

Components Shipped

Carefully check the contents of the carton for damage that might have occurred in transit. Do not discard the carton or packaging material until all components have been checked against the following component list and the equipment has been installed and tested.

As shipped, the carton should contain one the following:

Part Number	Description
9000500	General Chemistry Model, 115V, 60 Hz
9000501	General Chemistry Pistol Model, 115V, 60 Hz
9000502	General Chemistry Model, 230V, 50 Hz
9000503	General Chemistry Pistol Model, 230V, 50 Hz
or	
9000600	HPLC Model, 115V, 60 Hz
9000601	HPLC Pistol Model, 115V, 60 Hz
9000602	HPLC Model, 230V, 50 Hz
9000603	HPLC Pistol Model, 230V, 50 Hz
or	
9000700	UF Model, 115V, 60 Hz
9000701	UF Pistol Model, 115V, 60 Hz
9000702	UF Model, 230V, 50 Hz
9000703	UF Pistol Model, 230V, 50 Hz
or	
9000704	HPLC/UF Hybrid, 115V, 60 Hz
9000705	HPLC/UF Hybrid, 230V, 50 Hz
9049600	Manual, PS
9109100	Spanner Wrench
9108200	Template
1050306	Guide to Laboratory Water Purification
1334500	Power Cord, 115V
or	
1334100	Power Cord, 230V
1541700	Tube Support
1552500	Tube, Polyurethane Black 3/8 O.D. x 1/4 I.D x 5'.
9013415	Tube, Parflex 3/8 O.D. x 1/4 I.D. x 5'
1895320	Tapping Screw, Wall Mount 1/4-14 x 1-1/4" Lg.

INTRODUCTION

General Description

The Labconco WaterPro PS Polishing Stations have been specifically designed to meet the ultrapure water needs in a variety of laboratory applications.

The most basic of WaterPro models, General Chemistry, is ideally suited for typical chemical research labs. The WaterPro PS/HPLC models are specifically designed for demanding analytical chemistry work, involving sensitive instrumentation and requiring the lowest levels of Total Organic Carbon (TOC). The WaterPro PS/UF models are suited for bio-analytical research, requiring bacteria and/or pyrogen-free water.

Prepurified water of a minimum purity of 100µs or better is plumbed to the WaterPro PS through a 3/8" feedwater supply line. The built-in regulator allows the unit to accept water pressure from 0-100 psi. The feedwater must flow at a rate of 2 liters/minute or greater at the given inlet pressure.

The General Chemistry model purifies the water to Type I quality through the use of carbon and deionization resins and provides a typical flow rate of 1.8 liters/minute. The HPLC models allow for the addition of an organic adsorption cartridge and includes a dual wavelength ultraviolet reactor to oxidize last traces of organic compounds ensuring ultra low levels of total organic carbon. The Life Science models provide Type I water free of bacteria and pyrogens through the use of an ultrafilter and germicidal ultraviolet reactor. The HPLC/Hybrid models not only gives HPLC quality water through the use of the ultraviolet reactor, but deliver low level bacteria and pyrogen-free water.

Each model has the capability of displaying water quality, water temperature, low resistance set point and a programmable time dispense mode. Each model is offered with a dispensing valve, with or without a dispensing gun. Figure 1 shows models with dispensing gun and with dispensing valve only. A 0.2 micron self-venting hollow fiber final filter can be added to the gun or valve as an accessory when required. Ultrafilters and optional 0.2 micron final filters will reduce pure water flow rates. Figures 2, 3, 4 and 5 show the flow diagrams for each model.

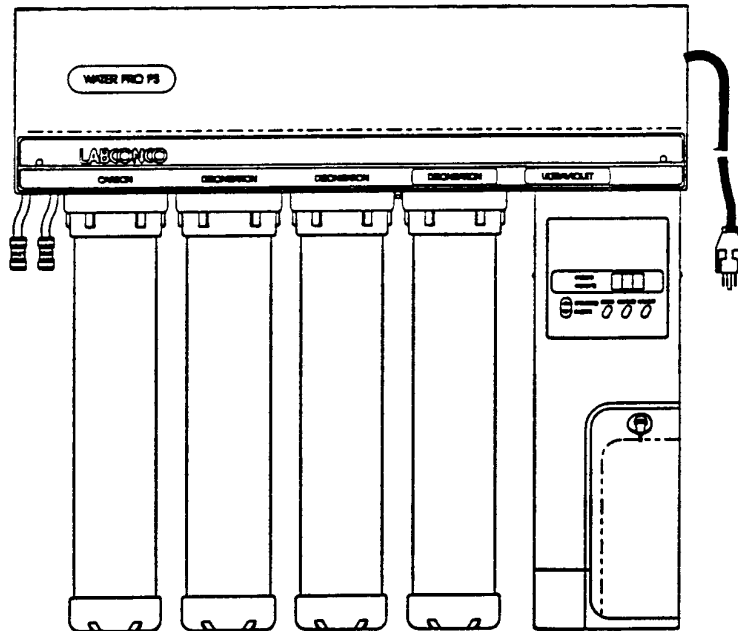
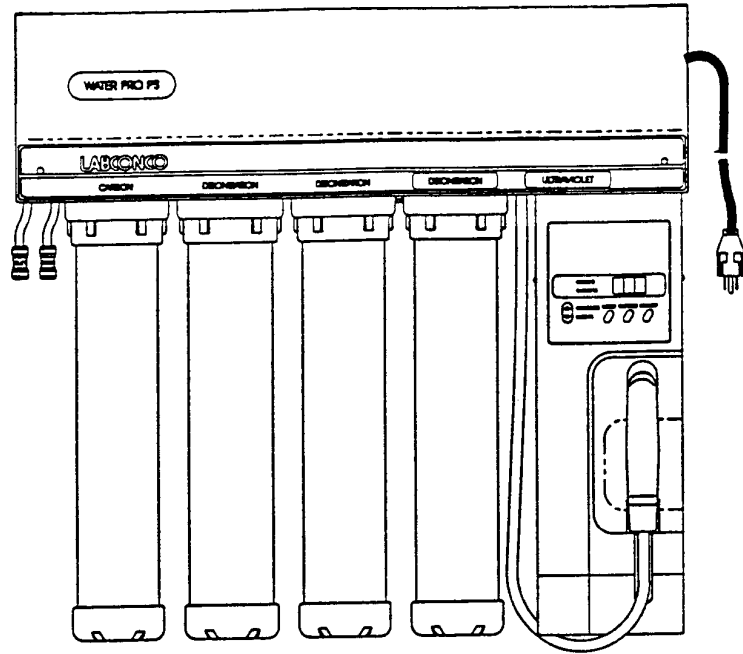
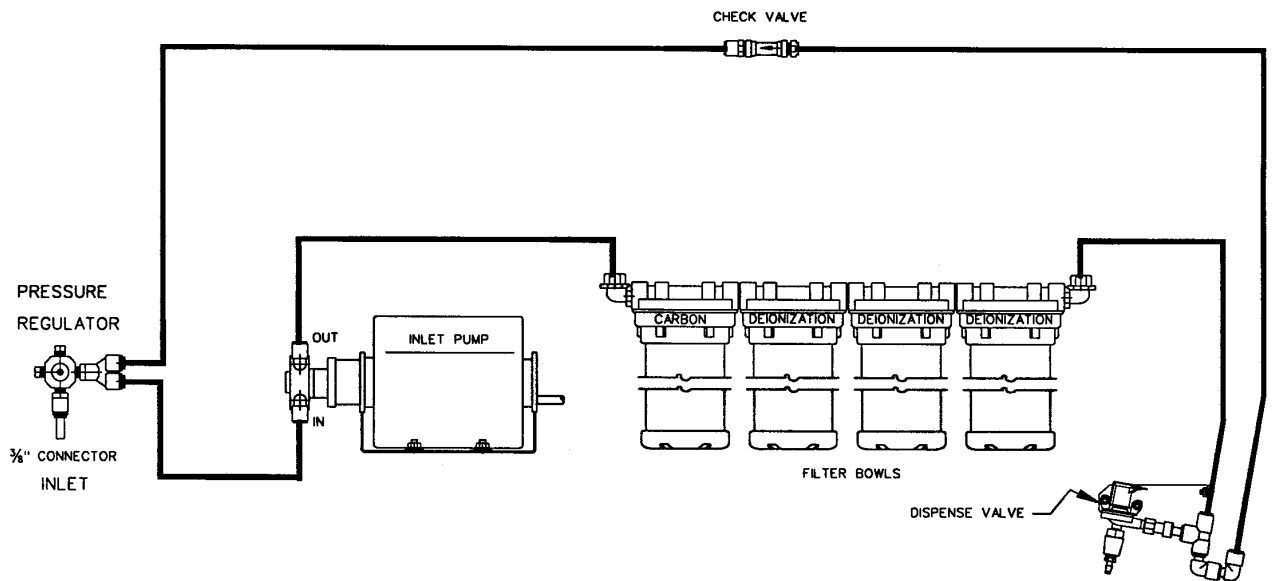
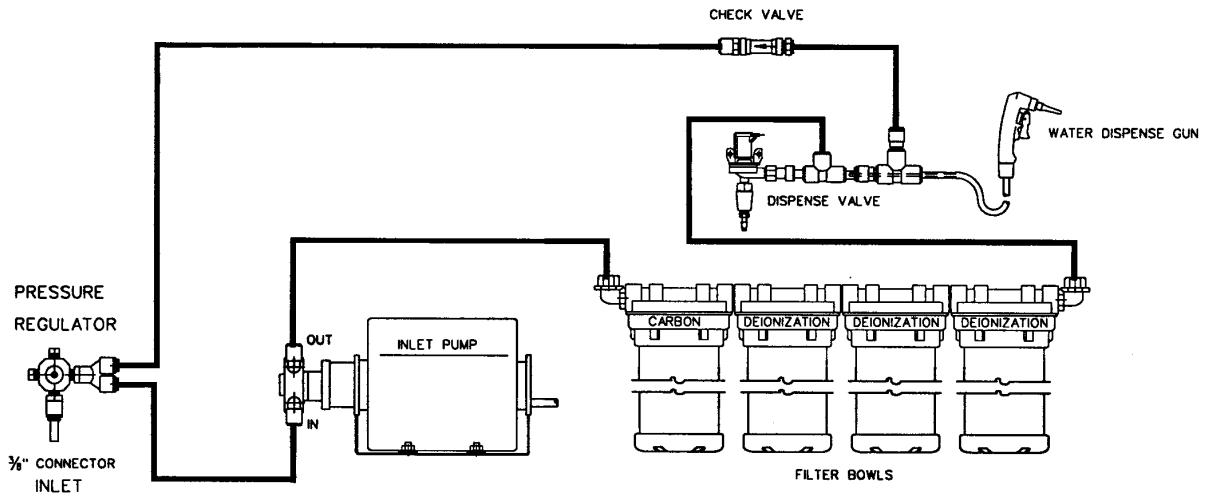

Figure 1

INTRODUCTION

GENERAL CHEMISTRY

MODELS 90005-01 & 90005-03



MODELS 90005-00 & 90005-02

Figure 2

HPLC ANALYTICAL INSTRUMENT

MODELS 90006-01 & 90006-03

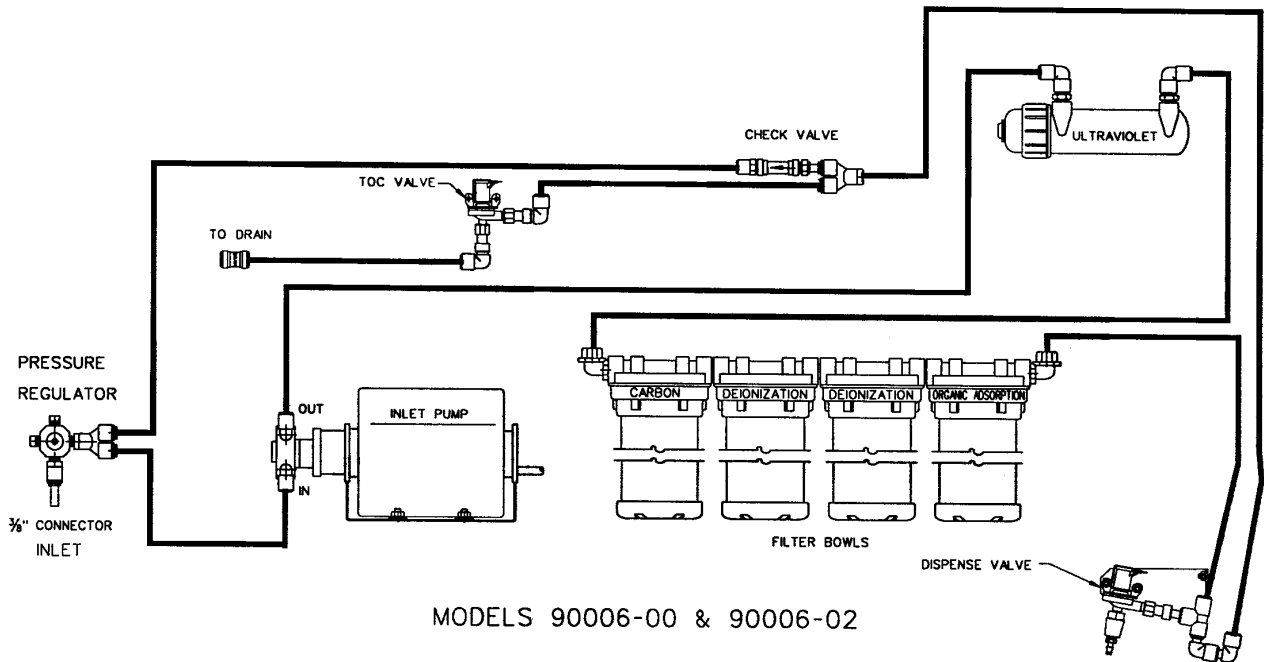
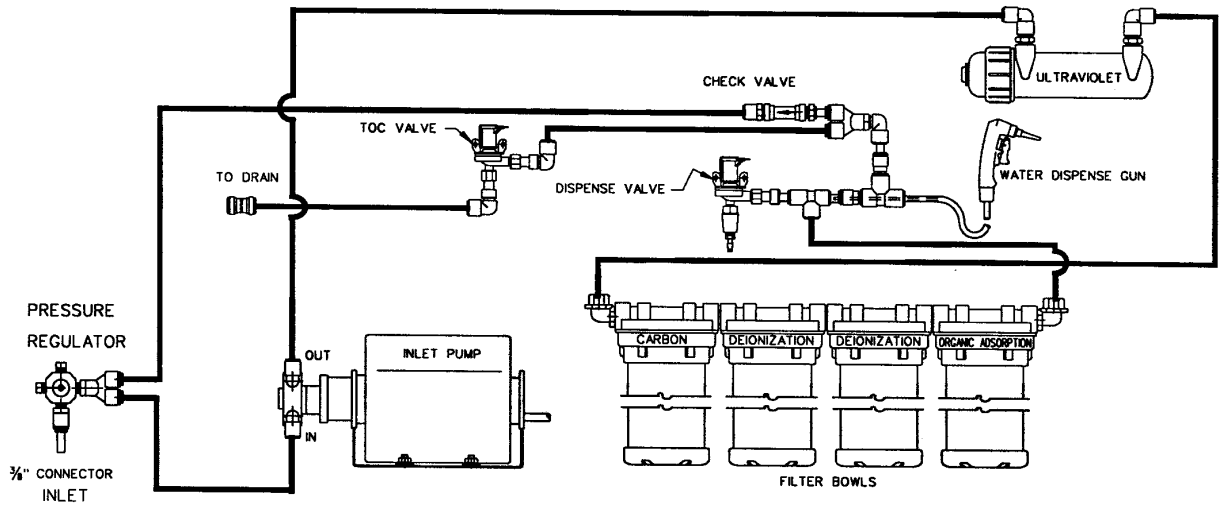

MODELS 90006-00 & 90006-02

Figure 3.

INTRODUCTION

ULTRAFILTER LIFE SCIENCES

MODELS 90007-01 & 90007-03

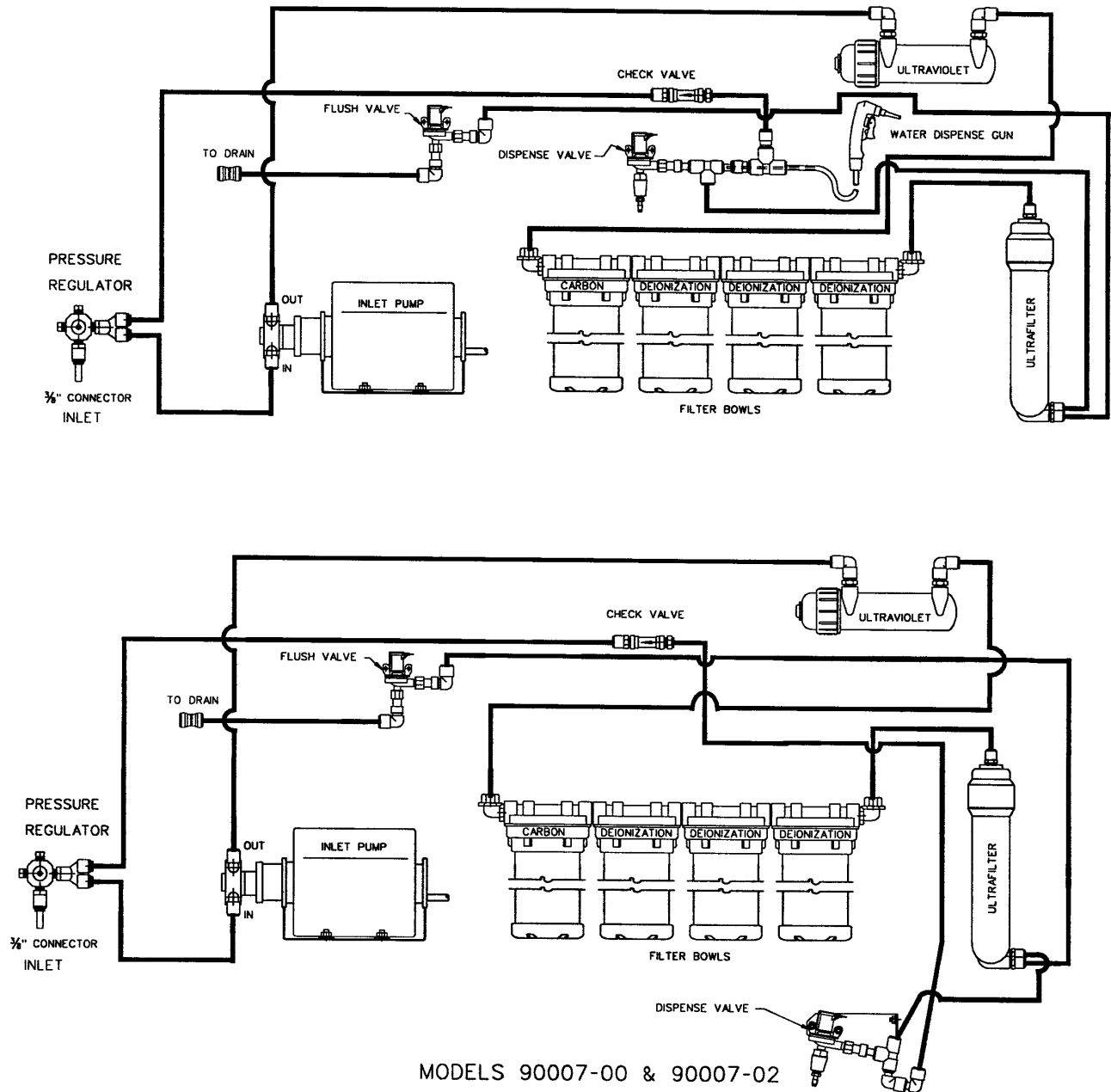

Figure 4

HPLC/ ULTRAFILTER HYBRID

MODELS 90007-04 & 90007-05

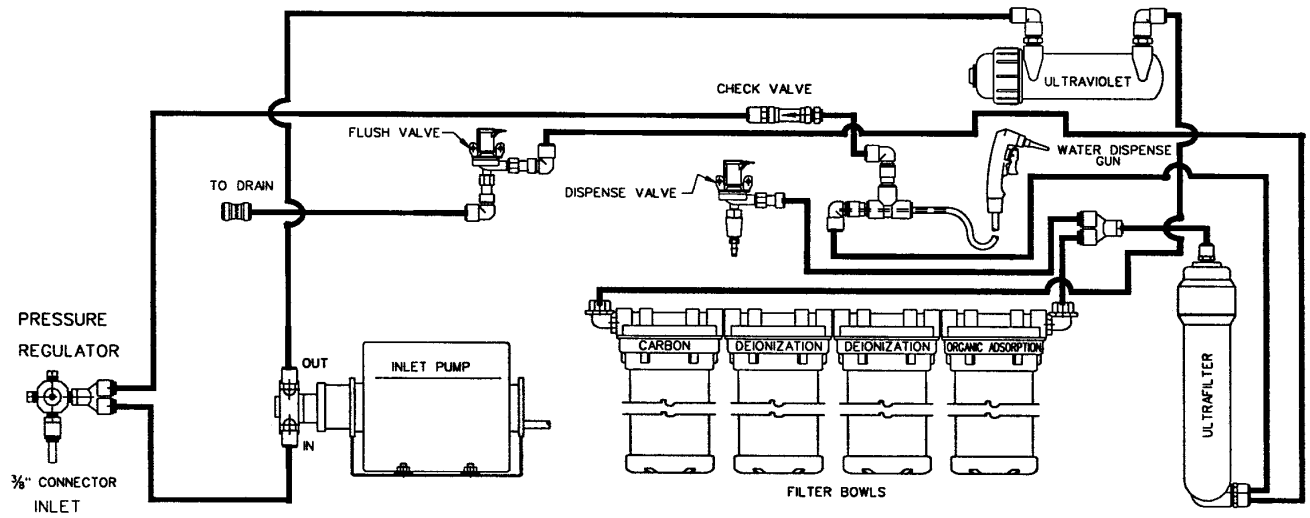
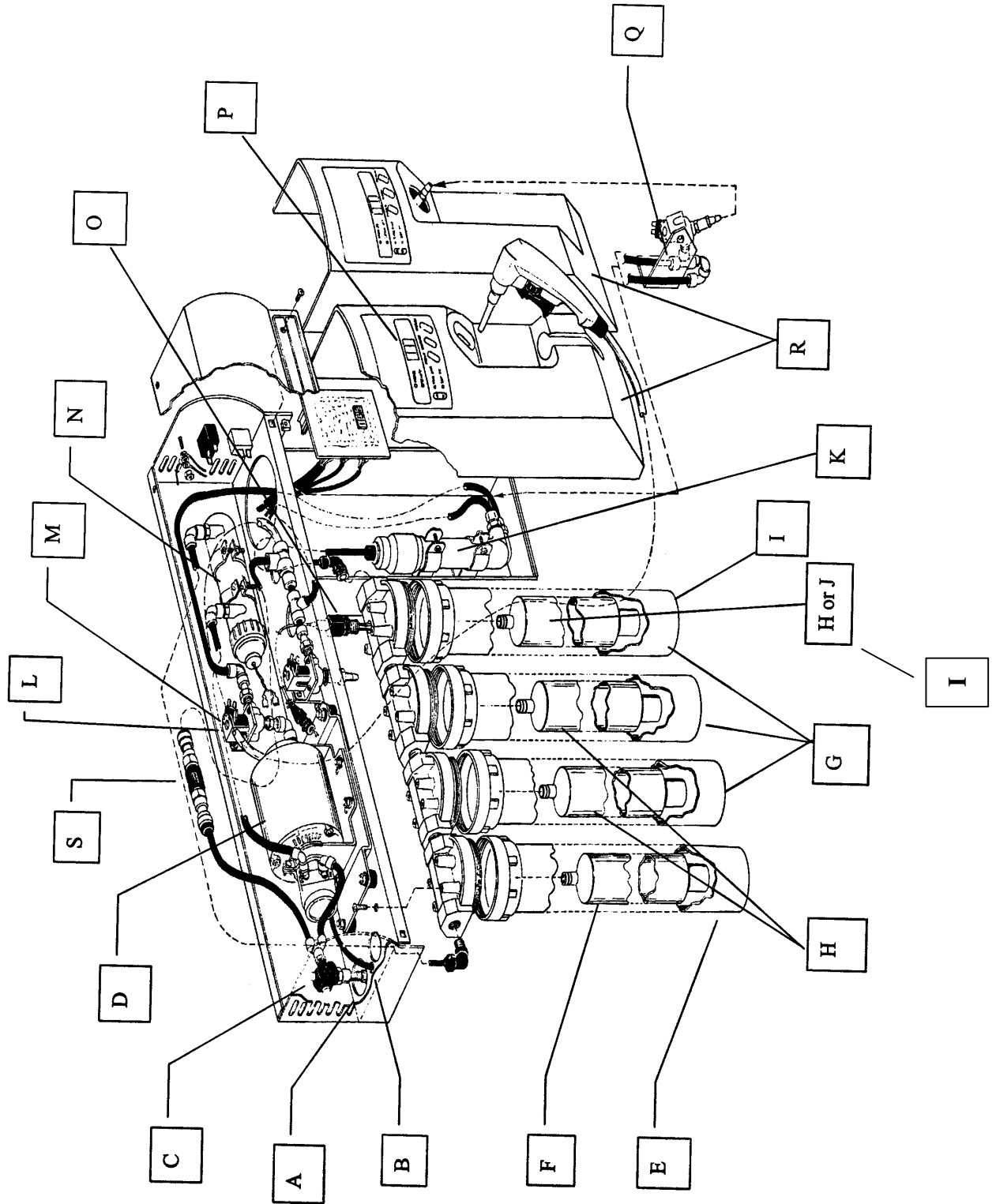

Figure 5

INTRODUCTION

Component Identification

- (A) **Inlet Port (located on underside).** Connects the WaterPro PS to the feedwater supply line (3/8" OD (0.95 cm) rigid plastic tubing). Feedwater must have a pressure of 0 – 100 psi, a minimum flow rate of 2 liters/minute and a conductivity of 100 μ S or less.
- (B) **Drain Port (located on underside).** Connect 3/8" OD (0.95 cm) line and route to drain. (HPLC, Life Science and Hybrid models only)
- (C) **Pressure Regulator.** Protects the system from excessive inlet pressure. Factory adjusted and should not require readjustment providing inlet pressure does not exceed 100 psi.
- (D) **Recirculation Pump & Motor.** Circulates water through the system. This pump is a rotary vane self priming pump that requires water flow for lubrication. Operation of system without an inlet water supply will damage the pump.
- (E) **Carbon Cartridge Bowl.** Unpigmented virgin polypropylene bowl that houses the carbon cartridge for the removal of organics. Cartridges must be ordered separately. (Insert cartridge with O-ring pointing up as shown.)
- (F) **Carbon Cartridge.** Refer to page 17 for correct installation. O-ring must point up as shown.
- (G) **Deionization Cartridge Bowls.** Unpigmented virgin polypropylene bowls that house the nuclear grade ion exchange resin for the removal of ionic contaminants. Cartridge must be ordered separately. (Insert cartridge with O-ring pointing up as shown.)
- (H) **Deionization Cartridges.** Refer to page 17 for correct installation. O-ring must point up as shown.
- (I) **Organic Adsorption Cartridge Bowl (HPLC and Hybrid Systems only).** Unpigmented virgin polypropylene bowl that houses the organic adsorption cartridge for the removal of trace organic contaminants. Cartridges must be ordered separately.
- (J) **Organic Adsorption Cartridge.** Refer to page 17 for correct installation. O-ring must point up as shown.
- (K) **Ultrafilter (UF Systems only).** Removes particles, bacteria, microorganisms and pyrogens greater than 0.01 micron in diameter. (10,000 Dalton cut-off)
- (L) **TOC Dump Valve (HPLC and Hybrid Systems only).** Directs a small portion of purified water to drain during automatic recirculation, reducing TOC levels in the system.
- (M) **Ultrafilter Flush Valve (UF and Hybrid Systems only).** Allows for UF membrane to flush during automatic recirculation operations.
- (N) **UV Reactor (HPLC, UF and Hybrid Systems only).** Irradiates the purified water before it is dispensed, ensuring low bacteria and organics. (Dual wavelength at both 185 and 254 nm)
- (O) **Resistivity Sensor.** Provides measurement of resistivity (purity) of the water.
- (P) **Electronic Control Center.** Provides ON/OFF, DISPENSE and MODE keys, along with digital and LED displays.
- (Q) **Dispense Valve.** Controlled by the dispense key. Located in the cabinet on gun models and in the dispense housing for non-gun models.
- (R) **Dispense Housing.** Contains the electronics, dispense valve or gun depending on model.
- (S) **Check Valve.** Prevents inlet water from bypassing filter cartridges during dispense.



SPECIFICATIONS

System Description:	Self contained, cartridge water purification system.
Technologies:	<p>GENERAL CHEMISTRY Activated carbon adsorption, deionization.</p> <p>HPLC ANALYTICAL INSTRUMENT MODELS Activated carbon adsorption, deionization, organic adsorption, and ultraviolet irradiation at both 185 and 254 nm.</p> <p>UF LIFE SCIENCE MODELS Activated carbon adsorption, deionization, ultrafiltration and ultraviolet irradiation at both 185 and 254 nm.</p> <p>HPLC/UF HYBRID MODELS Activated carbon adsorption, deionization, organic adsorption, ultrafiltration and ultraviolet irradiation at both 185 and 254 nm.</p>
Typical Water Production Rate: (0-100 psi with a minimum feed rate of 2 liters per minutes)	<p>1.8 liters per minute for General Chemistry and HPLC models. Reduced to 1.2 liters/minute with the addition of a 0.2 micron final filter.*</p> <p>1.1 liters per minute for Ultrafiltered models. Reduced to 1 liter per minute with the addition of 0.2 micron final filter.*</p>
Water Dispensing Systems:	<p>GUN DISPENSING MODELS Dispense from gun by depressing trigger or from dispense valve by pressing dispense key. Release trigger or key to stop flow. Timed dispense from dispense valve only. Optional hollow fiber filter can be installed on both gun and dispense valves by removing threaded nozzle and replacing with hollow fiber filter.</p> <p>NON-GUN DISPENSING MODELS Dispense by pressing dispense key. Release key to stop flow.</p>
Water Quality Produced:	<p>Meets or exceeds the following:</p> <ul style="list-style-type: none">• American Society for Testing and Materials Type I Water• National Committee for Clinical Laboratory Standards Type I Water

SPECIFICATIONS

*Actual flow rates for ultrafiltered models could vary as much as $\pm 15\%$ depending on the membrane. Flow rates determined with new hollow fiber final filter installed. Flow rate from final filter decreases with use.

Weight (dry):	60 lbs. (27.2 kg)
Feedwater Requirements	
Type:	Prepurified via reverse osmosis, distillation or deionization, with a conductivity of $< 100\mu\text{S}$ (Tap water feed not recommended)
Temperature:	10-30 degrees Centigrade (32-83 degrees Fahrenheit)
pH:	4-10
Inlet Pressure and Flow:	0-100 psi (0-7 Bar) providing 2 liters/minute (0.5 gallons/minute) or better
Deionization Capacity:	General Chemistry models 2,360 Grains as CaCO_3 HPLC Analytical Instrument models 1,573 Grains as CaCO_3 UF Life Science models 2,360 Grains as CaCO_3 HPLC/UF Hybrid models 1,573 Grains as CaCO_3
Deionization:	High Purity Polishing grade mixed bed resin
Ultrafiltration: (membrane included on UF models)	Polysulfone membrane in a spirally wound configuration.
Final Filtration (Optional):	Self-venting 0.2 micron hollow fiber filter
Electrical Requirements:	115V, 60 Hz, 7.5 Amps or 230V, 50 Hz, 4.0 Amps Single Phase
Relative Humidity:	Less than 80%

SPECIFICATIONS

Environmental Conditions

The WaterPro PS is designed to operate safely under the following conditions:

- Indoor use
- Altitude up to 2,000M (6,562 Ft.)
- Ambient temperatures 5°C to 40°C (41°F to 104°F)
- Maximum relative humidity 80% for temperatures up to 31°C (88°F) decreasing linearly to 50% relative humidity at 40°C (104°F)
- Main supply voltage fluctuations not to exceed $\pm 10\%$ of the nominal voltage
- Transient over-voltages according to installation category II (over-voltage categories per IEC 1010)
- Pollution degrees 2 (Normally only non-conductive foreign matter, solid, liquid, or gaseous (ionized gases), that may produce a reduction of dielectric strength or surface resistivity occurs. Occasionally, however, a temporary conductivity caused by condensation must be expected, in accordance with IEC 664)

Environment

Help us reduce waste by recycling spent deionization cartridges. Each time you order a Polishing Kit it comes complete with recycling instructions. When you install the new cartridge, place the expended cartridge in the shipping container and return it to Labconco using the label provided. These cartridges are recycled into useful products rather than taking in our landfills.

Preparation

The WaterPro PS should be located adjacent to appropriate electrical, feedwater and drain connections. For further information, read the Service Connection Section below.

Do not remove the polishing unit from its shipping box until it is ready to be placed in its final location. Call Labconco at (800) 821-5525 or (816) 333-8811, or return the business reply card to obtain your WaterProfile test kit. Pretreatment of the feedwater will be recommended after analysis.

Inspection

The WaterPro PS has been fully tested and inspected prior to shipment. Inspect your unit thoroughly at the time of receiving shipment, report any damage that may have occurred in transit immediately to your carrier.

Installation

Unfold the installation template included and follow the instructions listed on it to prepare the surface for mounting. We have provided ¼-14 x 1.25" Lg tapping screws (1895320) for securing the unit to the wall. If the optional support stand has been purchased, discard the templates and follow instructions provided with stand.

Electrical Connection

The 115V WaterPro PS comes fully wired with electrical cord and plug to connect to a standard outlet. A fused 115 volt, 1 phase, 7.5 amp supply is required for 115V installations. The 230V unit comes fully wired with electrical cord without a plug. A fused 230V, 1 phase, 4 amp supply is required for 230V installation.

Feedwater Quality

The WaterPro PS systems are designed for use with water which has been pre-purified, such as distilled, reverse osmosis or deionized water with a conductivity of 100µS or less. Water with higher conductivity such as tap water will rapidly exhaust the deionization cartridges, and therefore is not recommended.

IMPORTANT NOTE: System performance and cartridge life span are directly related to the feedwater quality. It is important to establish feedwater quality before operating the unit. If you are uncertain about the quality of your feedwater, or would like us to calculate the capacity of your system's cartridges given your feedwater quality, contact Labconco at (800) 821-5525.

WARNING: Do not install the WaterPro PS directly over or near equipment that uses electrical service. Routine use and maintenance of the unit may involve water spillage and the potential for electrical shock if improperly located.

INSTALLATION

Feedwater Connection

The supplied feedwater line is 3/8" OD (0.95 cm) rigid plastic tubing. If more tubing is required, refer to Replacement Parts section of this manual. The tubing is inserted into the inlet port identified as A on page 13. At a convenient spot in the supply line, a valve should be installed so the WaterPro PS may be isolated from the feedwater supply when required. Line pressure should not exceed 100 psi (7 Bar).

To connect the feedwater supply to the inlet port, cut the tube with a sharp knife and check for burrs.

Tubing Installation

The tubing connectors used in the WaterPro PS have been selected for their dependability and ease of installation. A detailed drawing of a typical connection is shown in Figure 6.

For flexible tubing, insert a tube support into the end of the tubing. Rigid tubing does not require the use of a tube support.

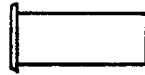

TUBE SUPPORT

1. Insert tube support if flexible tubing is used.
2. Moisten the end of the tubing with water and insert straight into the fitting until the tubing bottoms on the fitting shoulder.
3. To remove the tubing from the fitting, press the gray collar in and pull the tubing straight out.

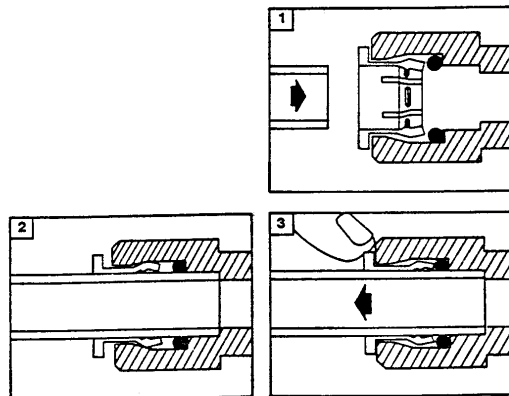

Figure 6

NOTE: When connecting the WaterPro PS to a non-pressurized feedwater supply, such as a storage tank, use a tube with at least 1/4" inner diameter. The length of the supply tube should not exceed 5 feet.

NOTE: Organic adsorption and deionization cartridges have a finite capacity for purifying water before being exhausted. As the cartridges approach exhaustion, the system will require longer recirculation times to achieve 16 – 18.2 megohm-cm resistivity and the water quality may fluctuate during dispensing. Upon exhaustion, the resistivity will decrease rapidly without recovery. Replacement of the deionization and/or organic adsorption cartridges will restore water purity.

NOTE: On Ultrafiltered models with new membranes or membranes that have not been used for a period of time, allow water to dispense to drain for a period of two hours and recirculate overnight before use. Failure to do so may cause contamination in the system and/or false megohm readings. A preservative has been added to the membrane to prevent bacterial growth and freezing.

Drain Connections

The HPLC, UF and Hybrid models are equipped with a drain line that must be routed to an open drain. Install the flexible tubing provided into the fitting marked drain, identified as B on page 13. It is important to weight the line or attach permanently to the drain to prevent the line from coming out of the drain due to the water pressure during the flush cycle.

SAFETY PRECAUTIONS

WARNING: Ensure that the unit is connected to electrical service in accordance with local and national electrical codes. Failure to do so may create a fire or electrical hazard.

WARNING: Ensure that the WaterPro PS is connected to a prepurified source of water, such as distilled, reverse osmosis or deionized with a conductivity of 100µS or less. Water of lesser quality will rapidly exhaust the carbon, deionization and organic adsorption cartridges and will prematurely destroy the ultrafilter membrane. All feed and drain lines should be connected and routed in accordance to local and national plumbing codes.

WARNING: Do not install the WaterPro PS over or near equipment that uses electrical service. Routine use and maintenance of the unit may involve water spillage and the potential for electrical shock if improperly located.

WARNING: The WaterPro PS automatically starts and stops at intervals during nonuse. To prevent the possibility of water spillage or electrical shock, always unplug the unit prior to servicing it.

WARNING: The ultraviolet lamp, used in models so equipped, emits small amounts of ultraviolet radiation during operation. **ALWAYS** unplug the system before removing the unit cover or servicing the lamp.

WARNING: When sanitizing the system:

- Avoid splashing the sanitizing solution on skin or clothing.
- Ensure that all piping connections are tight to avoid leakage.
- Always depressurize the system **COMPLETELY** before disassembly.
- If Ultrafilter model, plug unit into an electrical outlet, turn off feedwater supply, turn display off and push the dispense button to relieve pressure.
- Ensure adequate ventilation.

Carefully follow the manufacturer's safety instructions when handling sanitizers and always dispose of sanitizing solutions in accordance with local and national laws.

NOTE: Mounting surface composition, condition and construction must be considered when wall mounting this unit. The surface must be able to support at least 500 lbs. Inadequate support may result in damage to the mounting surface and/or equipment. We have provided ¼-14 x 1.25" Lg tapping screws (1895320) for securing the unit to the wall. Wall mounted units require a minimum of 6" clearance on the bottom for cartridge/sump bowl removal.

Initial Operation and Cartridge Installation

- (1) Remove the four polypropylene sump bowls by placing the spanner wrench as high as possible around the bowls. Unscrew each bowl by turning clockwise. With a twisting motion, install the carbon filter in the first bowl and other cartridges as indicated in the table below. Check each cartridge to ensure the black O-rings are seated properly into the bowl top (see page 13). Wetting of these O-rings will aid in installation. Carefully thread the bowls back into the position and hand tighten to seal the bowl O-rings. When installing new replacement cartridges on ultrafiltered models, plug unit into an electrical outlet, turn OFF display with the ON/OFF switch and press the dispense button until the pressure in the system is relieved. Disconnect from electrical power before removing cartridges.

**CARTRIDGE INSTALLATION SEQUENCE
(BOWLS ARE NUMBERED 1-4 FROM LEFT TO RIGHT)**

Model	Bowl Number	Cartridge Type	Kit Number	Part Number
General Chemistry Models 9000500, 9000501, 9000502, 9000503	1	Carbon	9047101	9007201
	2	Deionization		9007301
	3	Deionization		9007301
	4	Deionization		9007301
HPLC and HPLC/UF Hybrid 9000600, 9000601, 9000602, 9000603, 9000704, 9000705	1	Carbon	9047201	9007201
	2	Deionization		9007301
	3	Deionization		9007301
	4	Organic Adsorption		9053300
Life Science Models 9000700, 9000701, 9000702, 9000703	1	Carbon	9047401	9007201
	2	Deionization		9007301
	3	Deionization		9007301
	4	Deionization		9007301
Ultrafilter is included and installed on all UF models				9104400
Hollow Fiber Final Filter (if required)				9092900

- (2) Place a suitable container or a hose that goes to a drain over the dispense valve or dispense gun nozzle and SLOWLY open the inlet supply valve.
- (3) Plug the unit into an electrical outlet and turn the power switch on.
- (4) If the optional filter P/N 9092900 has been ordered, remove it from its plastic bag and thread it into either the dispense valve or the gun. The nozzle on the valve or gun must be removed before installing hollow fiber final filter. Orient filter as shown on label. **HAND TIGHTEN ONLY**. Reference Figure 7.
- (5) Install the optional filling bell P/N 9044100 by pushing it into the final filter outlet. Filling bell will only fit over the final filter outlet when installed on the dispense valve and will not fit on a final filter installed on the gun. Reference Figure 7.

NORMAL OPERATION

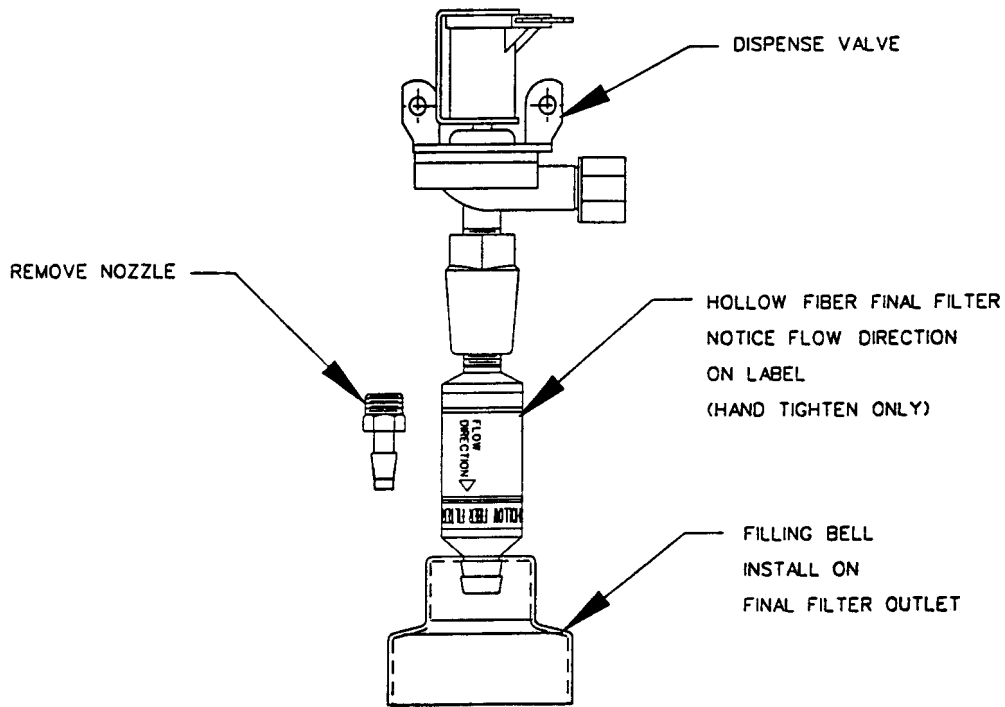

Figure 7

- (6) After installing new cartridges, the resistivity will slowly increase due to the removal of contaminants in the system and on the cartridges. Rinse up time may be as long as 24 hours before the resistivity equals or exceeds Type 1 specifications (16-18 megohm-cm resistivity). When the unit has set for period of time allow five minutes of operation to assure equivalent water purity throughout the system. New Ultrafiltered models may require longer time.

NOTE: On Ultrafiltered models with new membranes or membranes that have not been used for a period of time, allow water to dispense to drain for a period of two hours and recirculate overnight before use. Failure to do so may cause contamination in the system and false megohm readings. A preservative has been added to the membrane to prevent bacterial growth and freezing.

NOTE: When activating a new Polishing Station, or one that has new cartridges installed, the system will initially be full of air. This may cause the water quality display to operate erratically or incorrectly. This is common, and the display will resume normal operation when all of the air has been displaced from the system. Allow system to dispense to drain until all air has been removed. This is a normal air purging procedure.

Electronic Control (Refer to Figure 8)

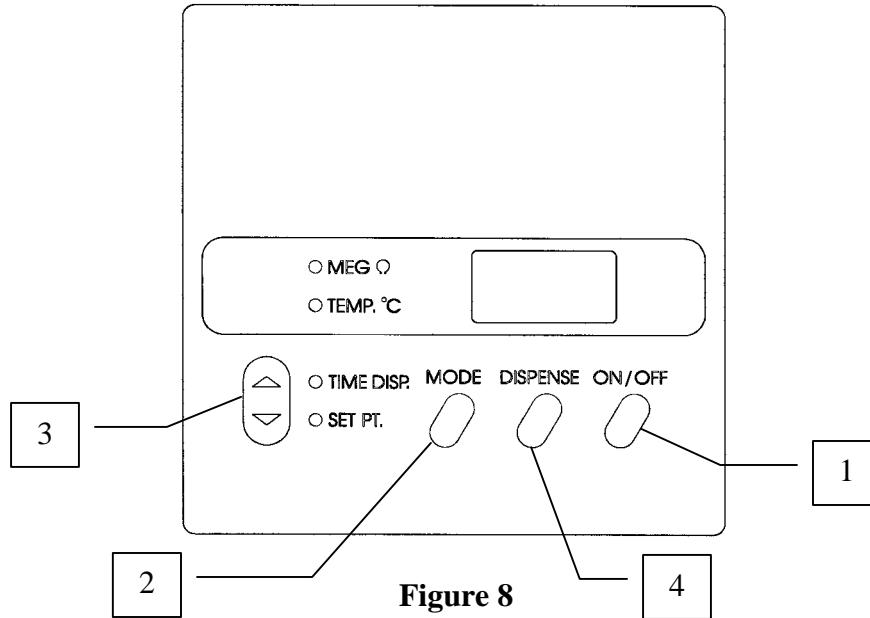

Figure 8

1. **ON/OFF Switch.** This switch starts the recirculation and lights the display. When the switch is in the OFF position the pump will automatically start and recirculate four minutes every two hours to prevent the system's water quality from degrading. Before automatic recirculation occurs the switch must be in the OFF position for a full two hours.
2. **Mode.** This key selects the mode of operation as indicated by the illuminated LED. Digital display indicates value as each mode is selected.
 - a. **MegOhm.** This is the normal operating mode and displays the water purity measured in resistivity.
 - b. **Temp.** Displays temperature of the water in degrees Centigrade.
 - c. **Time Dispense.** Displays amount of time in minutes the system will dispense water from the dispense valve. Time can be increased or decreased using arrow keys.
3. **Set Pt.** To display minimum desired resistivity setting (up to 16 MegOhm). Display will flash if water resistivity drops below set point. Set point can be increased or decreased using arrow keys.
4. **Dispense.** Pressing this key delivers water from the dispense valve. The key must be held down to continue dispensing. The delivery will be time controlled if that mode has been selected, and value entered into the display. Relieve pressure in Ultrafiltered models by first turning OFF the display with the ON/OFF switch and pressing the dispense key until pressure in system has been relieved.

NORMAL OPERATION

Automatic Intermittent Recirculation

All WaterPro PS Systems are designed to automatically start and recirculate water during periods of nonuse to minimize rinse up time and bacterial growth. The automatic recirculation cycles last for approximately 4 minutes every two hours. This automatic recirculation feature keeps rinse up time to highest purity at a minimum. During periods of frequent use, leaving the unit constantly on will provide Type I water instantly. When the unit has set for a period of time allow five minutes of operation to assure equivalent water purity throughout the system. New Ultrafiltered models may take longer.

Ultrafilter Flush Valve Operation

The ultrafilter flush valve, found only on Ultrafiltered models, has been preset to open and flush to drain for one minute on alternate recirculation cycles. (The valve opens for one minute every four hours), to flush and clean the ultrafilter membrane. Reference Item I on Page 9 of this manual.

Total Organic Carbon (TOC) Dump Valve Operation

The TOC flush valve, found on HPLC models, has been preset to open and flush to drain for one minute on alternate recirculation cycles (the valve opens for one minute every four hours), to maintain the lowest possible TOC values. Reference Item J on page 9 of this manual.

UV Lamp Replacement (HPLC, Life Science and HPLC/UF, Hybrid Models)

The UV lamp should be replaced annually to maintain intensity. To replace lamp, use the following procedure (Refer to Figure 9).

- (1) Unplug the WaterPro PS system and remove the front cover via the two screws on the front and two screws on the top of the cover.
- (2) Locate the ultraviolet reactors by referring to Item J under Component Identification located on Page 9 of this manual.
- (3) Disconnect the two white leads and pull the bulb from the reactor.
- (4) Insert new bulb P/N 9109200 into the reactor and reconnect the leads.

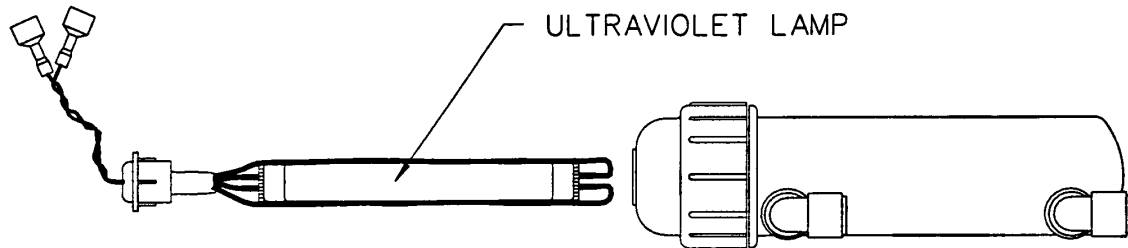

Figure 9

Cartridge Replacement

- (1) Organic adsorption and deionization cartridges have a finite capacity for purifying water before being exhausted. As the cartridges approach exhaustion, the system will require longer recirculation times to achieve 16-18.2 me/ohm-cm resistivity will decrease rapidly without recover. Replacement of the deionization and/or organic adsorption cartridges will restore water purity. The carbon cartridge should be replaced at the same time as the deionization cartridges are replaced.
- (2) Refer to page 17 of this manual under Initial Operation and Cartridge Replacement.

Replacement of Optional Final Filter – P/N 9092900

It is recommended that the optional 0.2 μ hollow fiber final filter P/N 90929-00 be replaced every 2-3 weeks when there is an unacceptably high passage of bacteria through the filter, or when the flow rate drops below an acceptable level. The filter should be replaced following the steps outlined on page 23, Item 8. When it's not required, the use of the final filter lowers flow rate unnecessarily.

MAINTENANCE

Replacement of Ultrafilter – P/N 9104400

On models with Ultrafilters, the Ultrafilter requires replacement if it has been damaged due to sanitization solution or is biofouled and releasing pyrogens of bacteria into the purified water.

1. Unplug the unit and remove four screws from the dispense housing. Lift housing away from dispense module exposing the wiring connector.
2. Disconnect wiring connector and set housing aside.
3. Locate ultrafilter shown as Item G on page 9 of the Component Identification section.
4. Disconnect inlet and outlet tubing by holding in the gray collar of the fitting and removing the tubing. Refer to Figure 10.
5. Remove the filter housing from its holder and unscrew the top exposing the ultrafilter.
6. Remove the element and replace with P/N 9104400. Assemble in reverse order.

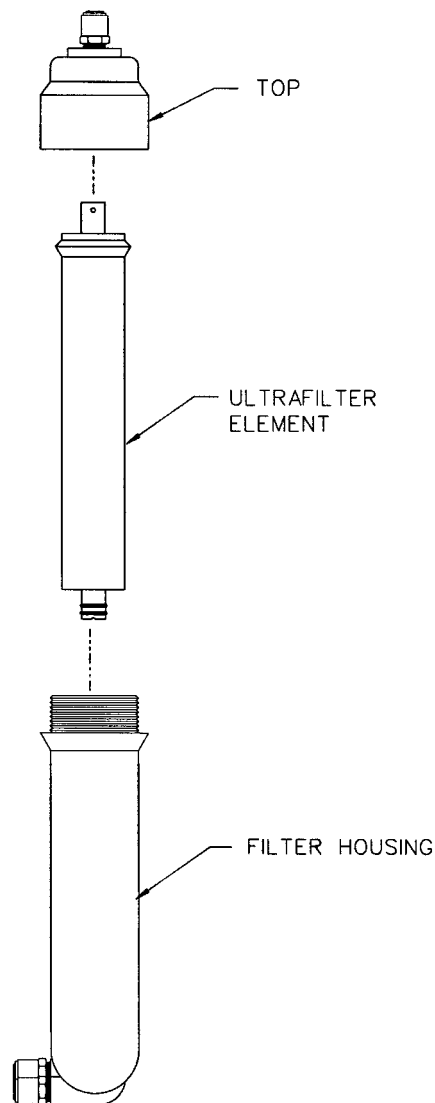

Figure 10

System Sanitization

Frequency of system cleaning and sanitization will depend directly on the quality of the feedwater and the operating environment of the unit. The unit should be cleaned when needed, such as when the bacterial or organic containment concentrations become unacceptable.

SANITIZE ALL MODELS AS FOLLOWS:

1. Close the feedwater inlet valve (supplied by customer), turn off the display on the Ultrafilter model and release the pressure in the system by pressing the dispense button. Unplug the WaterPro PS and remove the cartridges and hollow fiber final filter at dispense (if installed), as described in the Cartridge Replacement section.
2. Prepare approximately 16 liters of **ONE** of the following solutions:
 - 0.3% Bleach (1 liter 5.25% household bleach in 15 liters of clean water)
 - OR
 - 2.0% Formaldehyde
 - OR
 - 3.0% Hydrogen Peroxide

WARNING: When sanitizing the system:

Avoid splashing the sanitizing solution on skin or clothing. Ensure that all piping connections are tight to avoid leakage. Always depressurize the system COMPLETELY by turning off the display and pressurizing dispense valve button. Ensure adequate ventilation. Carefully follow the manufacturer's safety instructions when handling sanitizers and always dispose of sanitizing solutions in accordance with local and national laws.

3. Fill each bowl approximately ½ full with sanitizing solution and reattach them to the unit. Connect a feedwater line to inlet port of the WaterPro PS (Item A, page 9 of this manual) and place it in the container of sanitizing solution.
4. Place a suitable container under the dispense valve or gun, turn on unit and allow to operate until a steady stream of sanitizing solution flows from the valve or gun.
5. Close the valve or gun and allow the WaterPro PS to recirculate the sanitizer for at least two hours, periodically opening the dispense valve or gun to sanitize it. After the sanitization is complete, unplug the unit and open the dispense valve to depressurize the system.
6. Carefully discard the sanitizing solution, **WITHOUT RINSING OUT THE BOWLS**.
7. Install new cartridge in the appropriate bowls, plug in and turn on the WaterPro PS.
8. Leave the dispense valve open until approximately 10 liters have been dispensed, then close the valve and install a new final filter on the dispenser, if required. Allow the unit to recirculate until the resistivity is acceptable. The unit is now ready for operation.

REPLACEMENT PARTS

ITEM	QTY	PART NO.	DESCRIPTION
1	1	9047500	Pump Assembly, 115 VAC
1	1	9047501	Pump Assembly, 220 VAC
2	1	1210101	Motor Pump, 115 VAC
2	1	1210102	Motor Pump, 200 VAC
3	1	1365000	Check Valve
4	1	9105300	Resistivity Cell
5	1	9106500	Dispense Valve, 115V
5	1	9108900	Dispense Valve, 230V
6	1	9103500	Printed Circuit Board
7	1	9104400	Ultrafilter Element (Not Shown). For Models 9000700, -01, -02, -03, -04, -05
8	1	9109200	Dual Wavelength Ultraviolet Lamp Replacement. For Models 9000600, -01, -02, -3, and 9000700, -01, -02, -03, -04, -05
9	1	9044100	Filling Bell (Not Shown)
10	1	9109300	Ultraviolet Field Installation Kit (Not Shown)
11	1	9109400	Ultrafilter Field Installation Kit (Not Shown)
12	1	1552500	Drain Tubing (Not Shown)
13	1	1549100	Inlet Tubing (Not Shown)

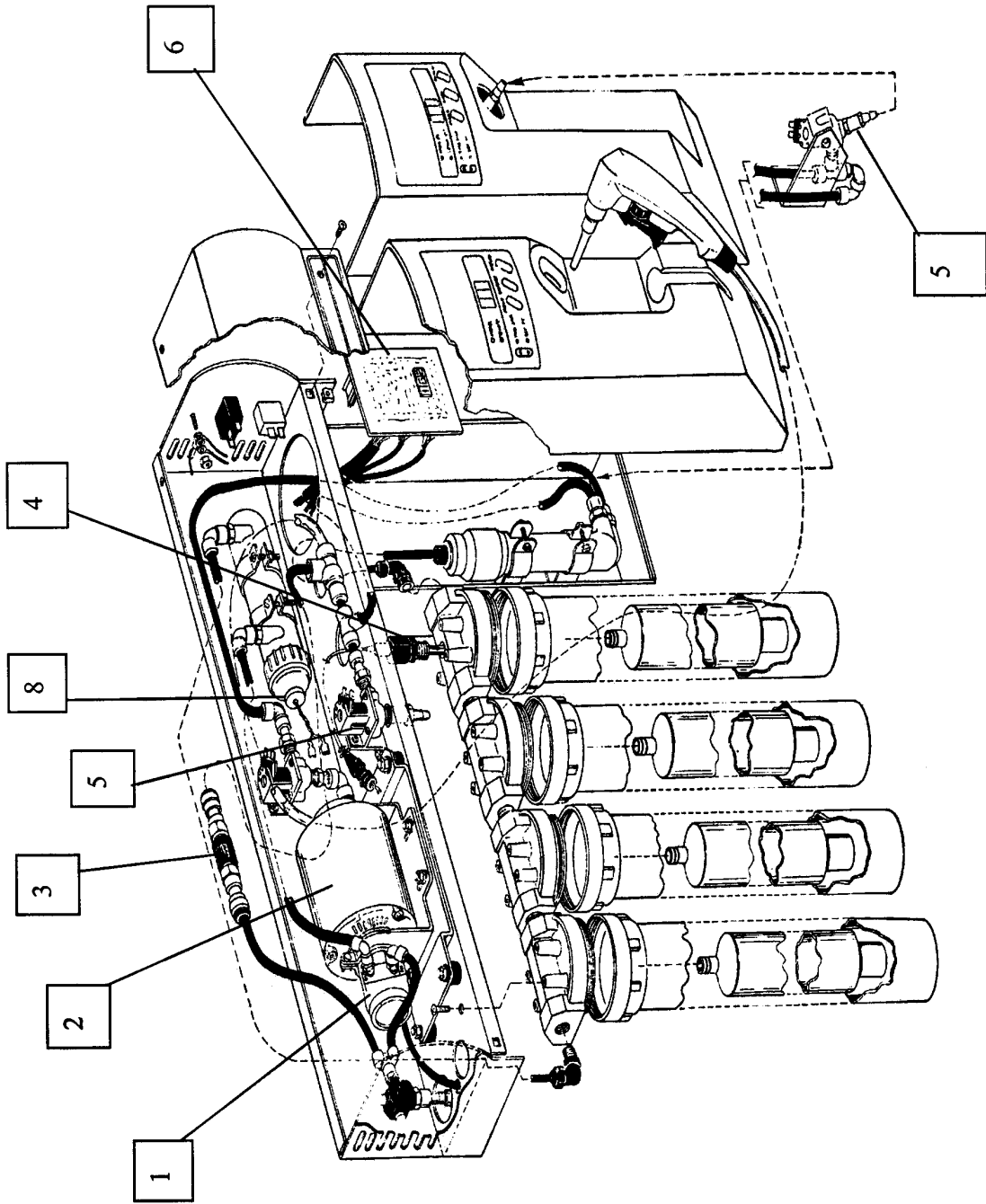

REPLACEMENT PARTS DIAGRAM

WIRING DIAGRAMS

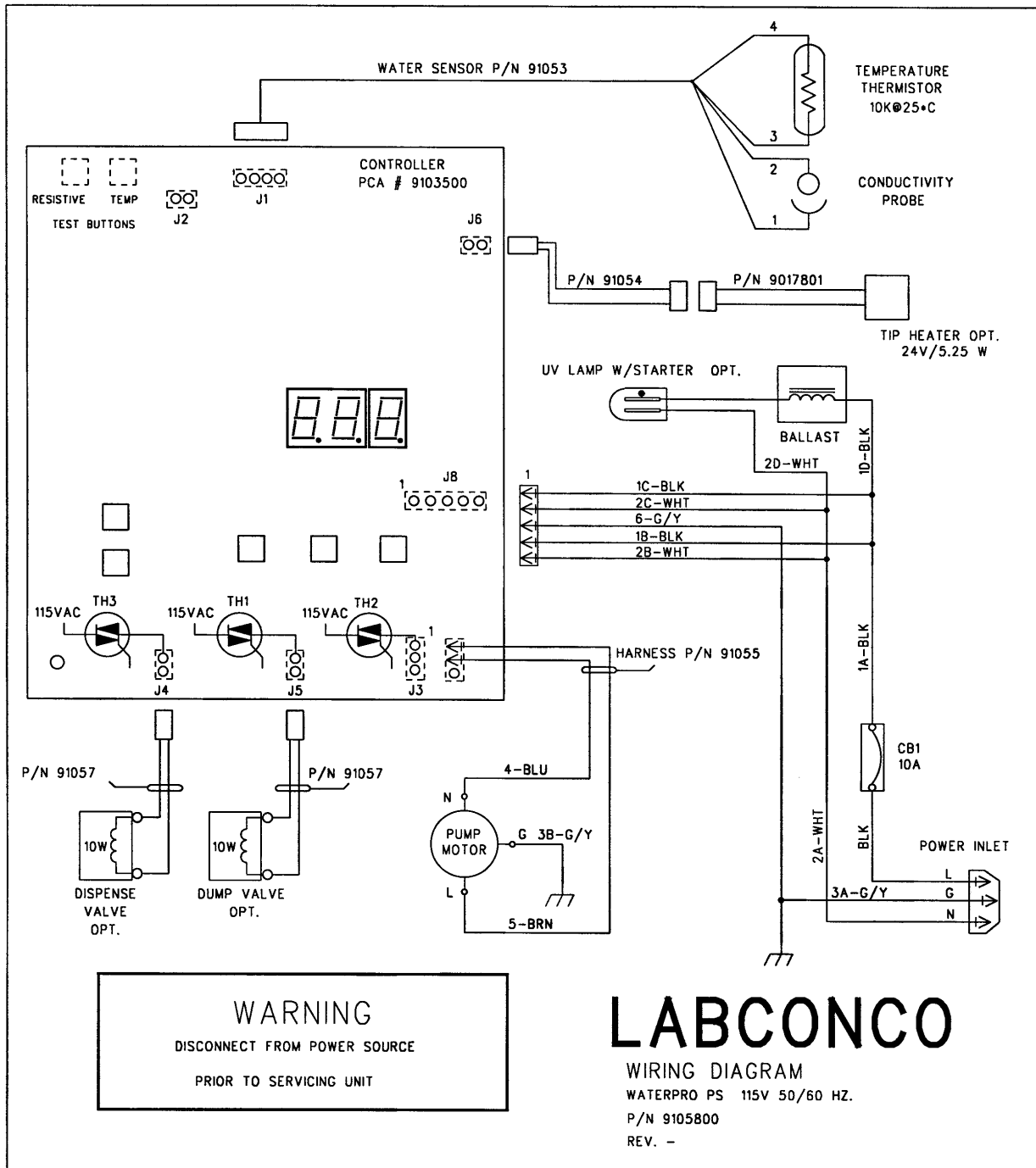

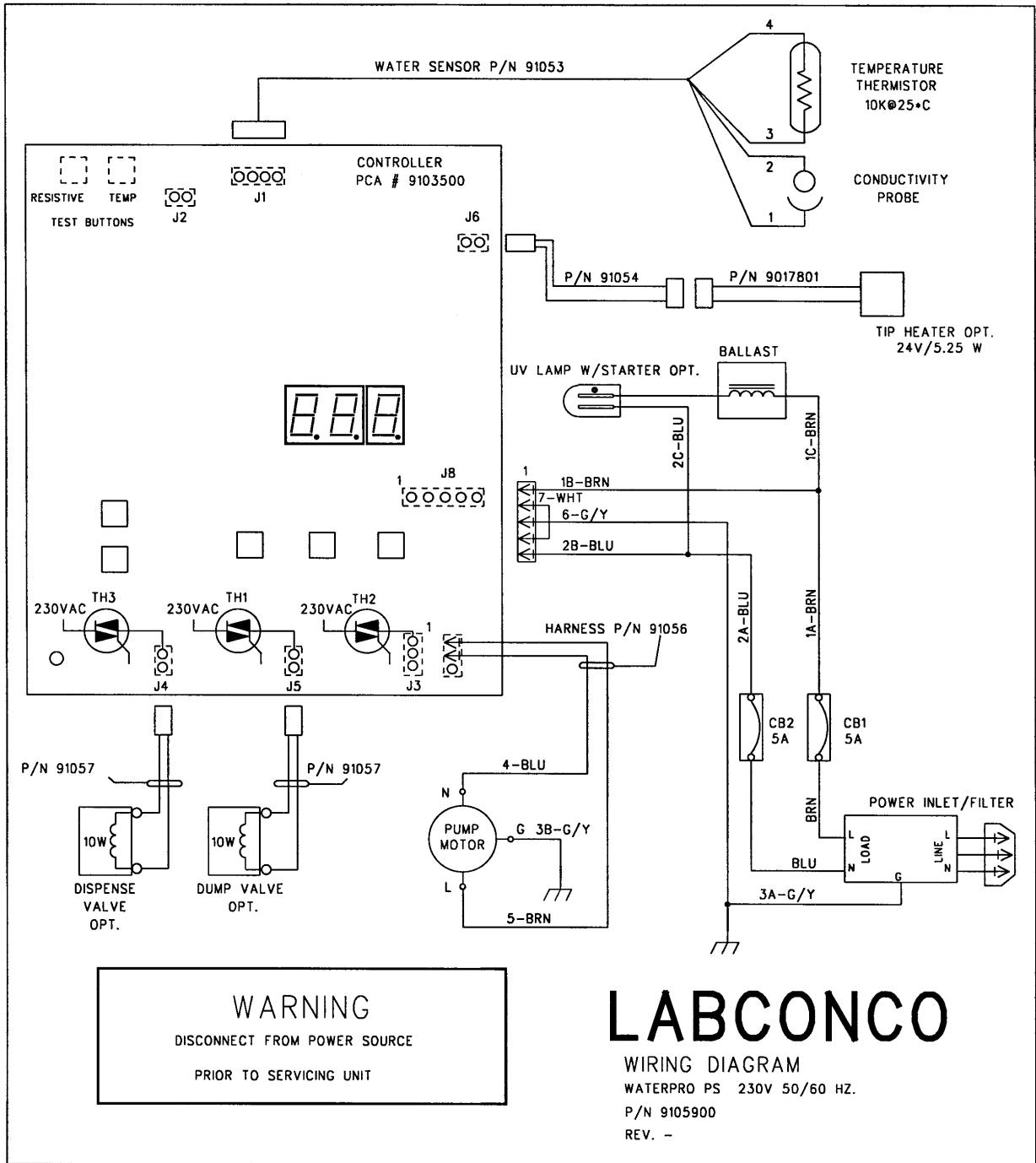

DIMENSIONAL DRAWING

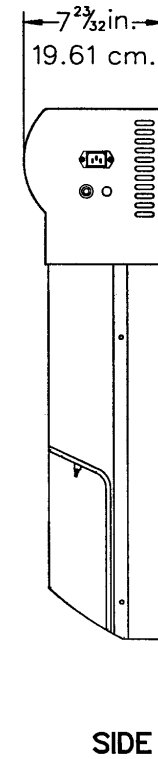
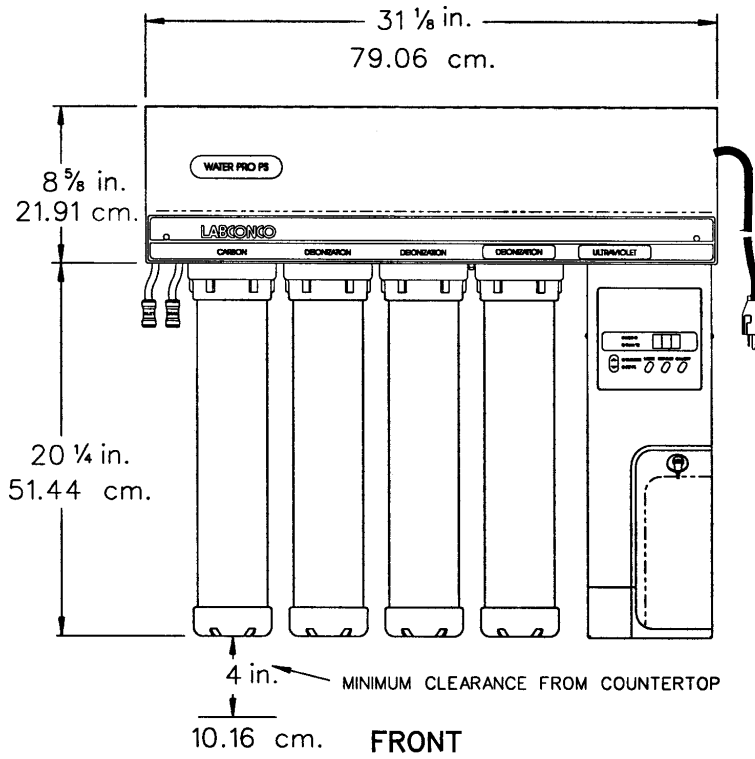
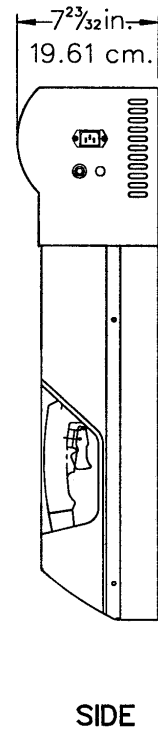
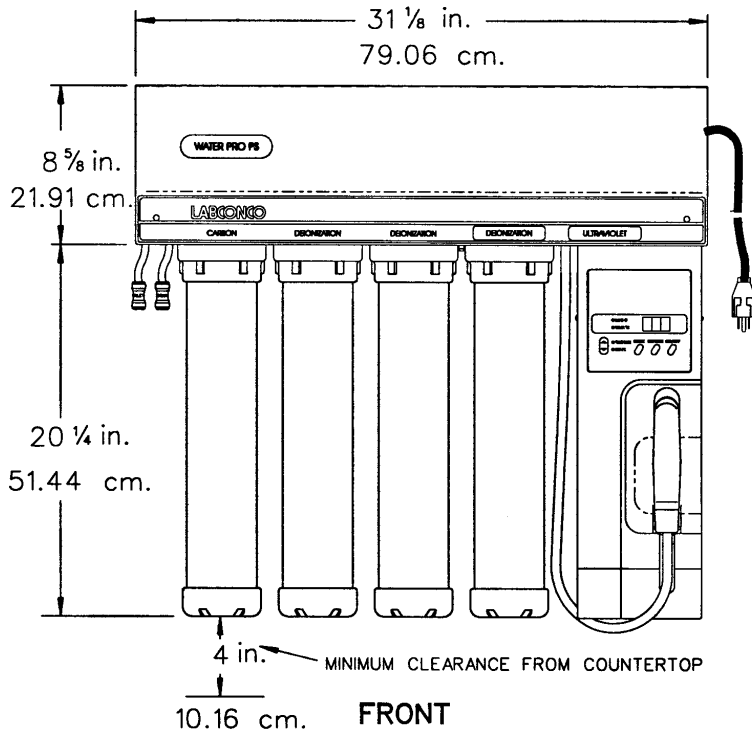

TROUBLESHOOTING

PROBLEM	CAUSES	CORRECTIVE ACTION
Unit inoperative, no display	Unit not plugged into outlet	Plug the Polishing Station into appropriate electrical service.
	Circuit breaker tripped/fuse blown	Reset circuit breaker/replace fuse.
	Power switch is in the off position	Press power button to switch system on.
	Defective circuit board	Replace circuit board.
Recirculation pump operates but no water is dispensed	Customer supplied feed valve is closed	Open the valve.
	Feedwater line is restricted, or no supply	Inspect and adjust feedwater line as required.
	Final filter is clogged	Replace final filter.
	Return line check valve is defective	Replace check valve assembly.
	Recirculation pump is defective	Replace recirculation pump.
Reduced flow at dispense valve/gun	Optional final filter is blocked	Replace final filter.
	Restricted tube in the feed line or polishing system	Inspect polishing loop tubing for any restrictions.
Water quality display acting erratically	New cartridges installed in system	Purge all of the air out of the polishing system.
	Air trapped in resistivity cell	Purge all of the air out of the polishing system.
	Deionization cartridges are exhausted	Replace the deionization cartridges.
	Polishing loop resistivity cell not connected to wiring harness	Reconnect cell to wiring harness.

TROUBLESHOOTING

PROBLEM	CAUSES	CORRECTIVE ACTION
Water quality display acting erratically (cont.)	Polishing loop resistivity cell is defective	Replace cell.
Polished water will not rinse up to desired quality	Cartridges are past expiration date	The shelf life of unopened cartridges is two years from the date of manufacture. Replace the expired cartridges with new ones. Check the manufactured date.
	Cartridges installed in wrong sequence	Install the cartridges as described in the “Initial Operation and Cartridge Replacement” section.
	Water is bypassing the cartridges	Ensure that the O-rings are at the top of the deionization cartridges and the posts at the top of the bowls are inserted correctly.
Reduced cartridge life	Cartridges are past expiration date	Check the manufactured date on the cartridge package. The shelf life of unopened cartridges is two years from the date of manufacture. Replace the expired cartridges with new ones.
	Feedwater quality has changed	<p>If the source is a reverse osmosis system, ensure that that it is working properly.</p> <p>If the source is a still, ensure that it is working properly and that the feedwater temperature is below 40°C (104°F).</p> <p>If the source is a central water supply, verify that it is still working properly.</p>

TROUBLESHOOTING

PROBLEM	CAUSES	CORRECTIVE ACTION
Odor from polished water	Bacterial growth on the filters	Remove old filters. Sanitize system. Install new filters.
	Old DI filters. DI resins breaking down	Remove old filters. Sanitize system. Install new filters.

ACCESSORIES

Accessories

Part #	Description
9077400	Support Stand – For mounting WaterPro PS on bench. Rests on countertop or other horizontal surface.
9113200	WaterPro RO/PS Mobile Stand Allows the mounting of a RO and PS on the same mobile stand.

Replacement Cartridges

Model	Polishing Kit	Components Included Part No.	Cartridge Type
General Chemistry	90471-01	9007201 (1)	Carbon
		9007301 (1)	Deionization
		9007301 (1)	Deionization
		9007301 (1)	Deionization
HPLC and HPLC/UF Hybrid	90472-01	9007201 (1)	Carbon
		9007301 (1)	Deionization
		9007301 (1)	Deionization
		9053300 (1)	Organic Adsorption
Life Science	90474-01	9007201 (1)	Carbon
		9007301 (1)	Deionization
		9007301 (1)	Deionization
		9007301 (1)	Deionization
		9104400 (1)	Ultrafilter
		9092900 (1)	Hollow Fiber Final Filter

We are committed to providing our customers with quality equipment and service after the sale. Part of this objective involves keeping you informed of changes and new product additions. We, therefore, request that you take a moment to fill out the product registration card so we may know your location as well as some of the reasons that prompted you to purchase our product.

Labconco provides a warranty on all parts and factory workmanship. The warranty includes areas of defective material and workmanship, provided such defect results from normal and proper use of the equipment.

The warranty for all Labconco products will expire one year from date of installation or two years from date of shipment from Labconco, whichever is sooner, except the following:

- Purifier® Delta® Series Biological Safety Cabinets carry a three-year warranty from date of installation or four years from date of shipment from Labconco, whichever is sooner.
- Carts carry a lifetime warranty.
- Glassware is not warranted from breakage when dropped or mishandled.

This limited warranty covers parts and labor, but not transportation and insurance charges. In the event of a warranty claim, contact Labconco Corporation or the dealer who sold you the product. If the cause is determined to be a manufacturing fault, the dealer or Labconco Corporation will repair or replace all defective parts to restore the unit to operation. Under no circumstances shall Labconco Corporation be liable for indirect, consequential, or special damages of any kind. This statement may be altered by a specific published amendment. No individual has authorization to alter the provisions of this warranty policy or its amendments. Lamps and filters are not covered by this warranty. Damage due to corrosion or accidental breakage is also not covered.

WARNING: The disposal and/or emission of substances used in connection with this equipment may be governed by various federal, state or local regulations. All users of this equipment are urged to become familiar with any regulations that apply in the user's area concerning the dumping of waste materials in or upon water, land or air and to comply with such regulations.

SHIPPING CLAIMS

If a shipment is received in visibly damaged condition, be certain to make a notation on the delivering carrier's receipt and have their agent confirm the damage on your receipt. Otherwise, the damage claim may be refused.

If concealed damage or pilferage is discovered, notify the carrier immediately and retain the entire shipment intact for inspection. Interstate Commerce Commission rules require that the claim be filed with the carrier within 15 days after delivery.

NOTE: Do not return goods. Goods returned without prior authorization will not be accepted. Labconco Corporation and its dealers are not responsible for shipping damage. Claims must be filed directly with the freight carrier by the recipient. If authorization has been received to return this product, by accepting this approval, the user assumes all responsibility and liability for biological and chemical decontamination and cleansing.

DECLARATION OF CONFORMITY

Application Council Directive(s): 73/23/EEC, 89/336/EEC

Standard(s) to which conformity is declared: EN61010, EN55014, EN50082-1

Manufacturer's Name: Labconco Corporation

Manufacturer's Address: 8811 Prospect Avenue
Kansas City, MO 64132 USA

Importer's Name: See Shipping/Customs Documents*

Importer's Address: See Shipping/Customs Documents

Type of Equipment: Laboratory Equipment

Model No.: WaterPro PS 90005-00, 01, 02, 03;
90006-00, 01, 02, 03;
90007-00, 01, 02, 03, 04, 05

Serial No.: Various – See Individual Declaration

Year of Manufacture: 1995 and Subsequent

I, the undersigned, hereby declare that the equipment specified above conforms to the above Directive(s) and Standard(s).

See individual Declaration of Conformity which
will be signed by the importer for your country.

Place: _____
(Signature)

Date: _____
(Full Name)

(Position)

*An individual version of this declaration is included with your shipping/customs documentation.

For more information, please contact us:

ExpotechUSA

10700 Rockley Road
Houston, Texas 77099
USA

281-496-0900 [voice]

281-496-0400 [fax]

E-mail: sales@expotechusa.com

Website: www.ExpotechUSA.com