

FreeZone® 4.5 Liter Benchtop Freeze Dry System Specifications

7750000 FreeZone® 4.5 Liter Benchtop Freeze Dry System

Cabinet, 22 7/16" h x 18" w x 22 3/4" d (57 x 45.7 x 57.8 cm) including permanently-installed drying chamber, shall be glacier white and charcoal epoxy-coated steel with white melamine-laminated 3/4" work surface and four leveling feet. Operating instruction label shall be mounted on the front panel. Three feet of 3/4" ID vacuum hose and two clamps shall be included.

Drying Chamber, 11 3/4" h x 9" diameter (29.8 x 22.9 cm), shall be stainless steel with 1/2" thick clear acrylic cover removable for defrosting and cleaning. Permanently installed drying chamber shall have 10 valves that accommodate 3/4" and 1/2" adapters.

Collector shall be upright stainless steel coil capable of collecting 4.5 liters of ice before defrosting. System shall remove over 2 liters of water in 24 hours. Retractable 9-inch condensate drain line shall be accessible from front of cabinet to facilitate defrost. A 1/3 hp, CFC-free refrigeration system shall cool collector to -50° C (-58° F).

Instrumentation and Controls shall include an LCD for display of system vacuum (10^{-3} mBar), collector temperature (° C) and alarm messages. A MENU switch shall change the display from system parameters to alarm message(s). LED vacuum and temperature "wave" graphs shall display relative system vacuum and collector temperature. Front panel shall have a power switch and touchpad switches with indicator lights for automatic refrigeration/vacuum, manual refrigeration and manual vacuum. Front panel shall also include a standard 8 pin DIN recorder jack and alarm light.

Electrical Requirements, 115 volts, 60 Hz, single phase, 7 amps without accessory vacuum pump. A 115 volt electrical receptacle shall be located on the back of the cabinet to connect the vacuum pump to the system. An 8-foot, 3 wire cord with 20 amp plug shall be provided. **A 115 volt, 60 Hz, 90 liter/minute vacuum pump shall be required for operation (not included).**

Shipping weight 125 lbs. (56.7 kg)

*

7750001 FreeZone® 4.5 Liter Benchtop Freeze Dry System

Specifications are the same as for 7750000 except for the following changes.

Electrical Requirements, 230 volts, 50 Hz, 3.5 amps without accessory vacuum pump. A 230 volt electrical receptacle shall be located on the back of the cabinet to connect the vacuum pump to the system. An 8-foot, 3 wire cord shall be provided. **An electrical plug shall be required (not included). A 230 volt, 50 Hz, 90 liter/minute vacuum pump shall be required for operation (not included).**

Agency Approvals. System shall have CE conformity marking as set by the European Community for electrical safety and electromagnetic compatibility.

7750003 FreeZone® 4.5 Liter Benchtop Freeze Dry System With Teflon*-Coated Collector

Specifications are the same as for 7750000 except for the following changes.

Collector chamber and coil shall be Teflon-coated for processes involving corrosive compounds.

* *International Electrical Configuration*

* *Teflon® is a registered trademark of E. I. duPont de Nemours*

FreeZone® 4.5 Liter Benchtop Freeze Dry System Specifications

* 7750004 FreeZone® 4.5 Liter Benchtop Freeze Dry System

Specifications are the same as for 7750000 except for the following changes.

Electrical Requirements, 208/230 volts, 60 Hz, 3.5 amps without accessory vacuum pump. A 230 volt electrical receptacle shall be located on the back of the cabinet to connect the vacuum pump to the system. An 8-foot, 3 wire cord shall be provided. **An electrical plug shall be required (not included). A 230 volt, 60 Hz, 90 liter/minute vacuum pump shall be required for operation (not included).**

Agency Approvals. System shall have CE conformity marking as set by the European Community for electrical safety and electromagnetic compatibility.

* *International Electrical Configuration*

FreeZone® 4.5 Liter Benchtop Freeze Dry System Dimensional Data

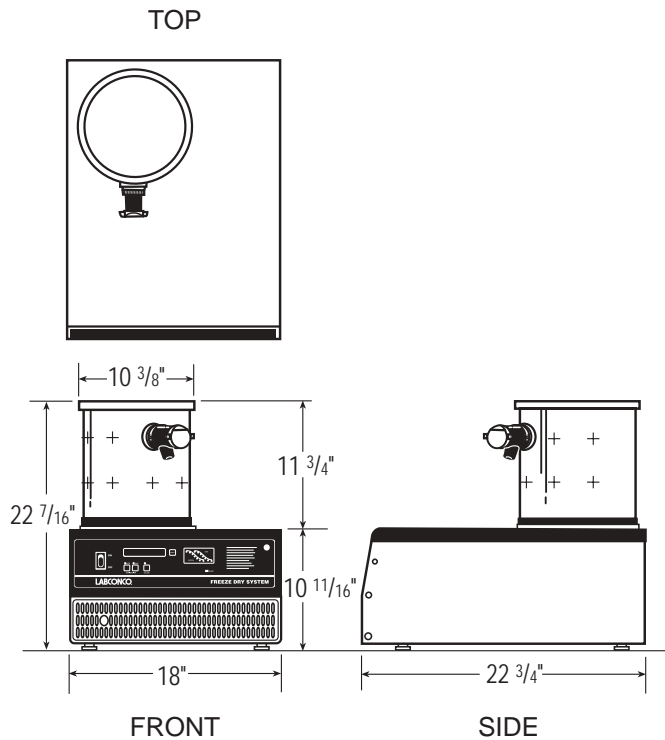

For more information, please contact us:

[ExpotechUSA](#)
[10700 Rockley Road](#)
[Houston, Texas 77099](#)
[USA](#)

[281-496-0900 \[voice\]](#)

[281-496-0400 \[fax\]](#)

E-mail: sales@expotechusa.com

Website: www.ExpotechUSA.com