



Protector[®] Demonstration Hoods

Models

3944300, 3944301

3945000, 3945001

3945020, 3945021



*Protecting your
laboratory environment*

CONCO[®]

For more information, please contact us:

ExpotechUSA

10700 Rockley Road
Houston, Texas 77099
USA

281-496-0900 [voice]

281-496-0400 [fax]

E-mail: sales@expotechusa.com

Website: www.ExpotechUSA.com

The information contained in this manual and the accompanying product is copyrighted and all rights are reserved by Labconco Corporation. Labconco Corporation reserves the right to make periodic design changes without obligation to notify any person or entity of such change.

Protector® Demonstration Hood

Warranty

Labconco provides a warranty on all parts and factory workmanship. The warranty includes areas of defective material and workmanship, provided such defect results from normal and proper use of the equipment.

The warranty for all Labconco products will expire one year from date of installation or two years from date of shipment from Labconco, whichever is sooner, except the following:

- Purifier® Delta® Series Biological Safety Cabinets and PuriCare® Procedure Stations carry a three-year warranty from date of installation or four years from date of shipment from Labconco, whichever is sooner.
- FlaskScrubber®, SteamScubber and FlaskScrubber Vantage® Series Glassware Washers carry a two-year warranty from date of installation or three-years from date of shipment from Labconco.
- Carts carry a lifetime warranty.
- Glass is not warranted from breakage due to accident or mishandling.

This limited warranty covers parts and labor, but not transportation and insurance charges. In the event of a warranty claim, contact Labconco Corporation or the dealer who sold you the product. If the cause is determined to be a manufacturing fault, the dealer or Labconco Corporation will repair or replace all defective parts to restore the unit to operation. Under no circumstances shall Labconco Corporation be liable for indirect, consequential, or special damages of any kind. This statement may be altered by a specific published amendment. No individual has authorization to alter the provisions of this warranty policy or its amendments. Lamps and filters are not covered by this warranty. Damage due to corrosion or accidental breakage is not covered.

Limitation of Liability

The disposal and/or emission of substances used in connection with this equipment may be governed by various federal, state, or local regulations. All users of this equipment are required to become familiar with any regulations that apply in the user's area concerning the dumping of waste materials in or upon water, land, or air and to comply with such regulations. Labconco Corporation is held harmless with respect to user's compliance with such regulations.

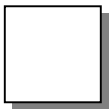

TABLE OF CONTENTS

CHAPTER 1: INTRODUCTION	1
About This Manual	2
Typographical Conventions	3
CHAPTER 2: PREREQUISITES	4
Support Requirements	5
Location and Air Current Requirements	5
Exhaust and Blower Requirements	5
Electrical Requirements	6
Space Requirements	6
CHAPTER 3: GETTING STARTED	7
Unpacking the Hood	8
Installing the Hood on a Supporting Structure & Work Surface	8
Connecting to the Exhaust System	10
Connecting the Electrical Supply	16
Sealing to the Work Surface	16
Validating the Hood	16
CHAPTER 4: HIGH PERFORMANCE FEATURES AND SAFETY PRECAUTIONS	17
High Performance Features	17
Safety Precautions	22
CHAPTER 5: USING YOUR PROTECTOR DEMONSTRATION HOOD	24
CHAPTER 6: MAINTAINING YOUR PROTECTOR DEMONSTRATION HOOD	26
Routine Maintenance Schedule	26
Calibration and Operation of Airflow Monitors	27
Guardian Jr. Airflow Monitor	27
Guardian Jr. Component Identification	28
Guardian Jr. Installation Procedure	29

Guardian Jr. Calibration Procedure	31
Guardian Jr. Alarm Activation	33
Guardian Jr. Alarm Test	33
Guardian Digital 1000 Airflow Monitor Operation	33
Guardian Digital 1000 Alarm Installation Procedure	33
Guardian Digital 1000 Alarm Calibration	35
CHAPTER 7: ACCESSORIZING YOUR PROTECTOR DEMONSTRATION HOOD	37
Work Surfaces	39
Guardian Digital 1000 and Guardian Jr. Airflow Monitors	39
Fluorescent Light	39
Exhaust Transition Adapters	40
Remote Blowers	40
Exhaust Dampers	41
FilterMate Portable Exhausters and Filters	41
Storage Cabinets	42
Mobile Cart 8026000	43
Hose, Hose Clamps and Hose Kits	43
CHAPTER 8: TROUBLESHOOTING	44
APPENDIX A: REPLACEMENT PARTS	46
APPENDIX B: DIMENSIONS	50
APPENDIX C: SPECIFICATIONS	53
APPENDIX D: REFERENCES	56
DECLARATION OF CONFORMITY	59

CHAPTER 1

INTRODUCTION

Congratulations on your purchase of a Protector® Demonstration Hood. Your high performance enclosure is designed to protect you by providing superior containment while conserving energy at OSHA approved “low flow” velocities as low as 60 feet per minute. It is the result of Labconco’s more than 50 years experience in manufacturing fume hoods.

The Protector Demonstration Hood has been engineered to provide maximum containment. It will effectively contain toxic, noxious, or other harmful materials when properly installed. The Protector Demonstration Hood offers many unique features to enhance safety, performance, and energy savings. To take full advantage of them, please acquaint yourself with this manual and keep it handy for future reference. If you are unfamiliar with how the Protector Demonstration Hood operates, please review *Chapter 4: High Performance Features and Safety Precautions* before you begin working in the hood. Even if you are an experienced user, please review *Chapter 5: Using Your Demonstration Hood*, which describes the features so that you can use the hood efficiently.

About This Manual

This manual is designed to help you learn how to install, use, and maintain your hood. Instructions for installing optional equipment on your hood are also included.

Chapter 1: Introduction provides a brief overview of the hood, explains the organization of the manual, and defines the typographical conventions used in the manual.

Chapter 2: Prerequisites explains what you need to do to prepare your site before you install the hood. Electrical and service requirements are discussed.

Chapter 3: Getting Started contains the information you need to properly unpack, inspect, install, and certify the hood.

Chapter 4: High Performance Features and Safety Precautions explains how the Protector Demonstration Hood operates and the appropriate precautions you should take when using the hood.

Chapter 5: Using Your Protector Demonstration Hood discusses the basic operation of how to prepare, use and shut down your hood.

Chapter 6: Maintaining Your Protector Demonstration Hood explains how to perform routine maintenance on the hood.

Chapter 7: Accessorizing Your Protector Demonstration Hood explains acceptable modifications to the hood or how to add accessories.

Chapter 8: Troubleshooting contains a table of problems you may encounter while using the hood including the probable causes of the problems and suggested corrective actions.

Appendix A: Components contains labeled diagrams of all of the components of the Protector Demonstration Hoods.

Appendix B: Dimensions contains comprehensive diagrams showing all of the dimensions for the hoods.

Appendix C: Specifications contains the electrical requirements for Protector Demonstration Hoods. Wiring diagrams are also included.

Appendix D: References lists the various resources available that address laboratory ventilation.

Typographical Conventions

Recognizing the following typographical conventions will help you understand and use this manual:

- Book, chapter, and section titles are shown in italic type (e.g., *Chapter 3: Getting Started*).
- Steps required to perform a task are presented in a numbered format.
- Comments located in the margins provide suggestions, reminders, and references.
- Critical information is presented in boldface type in paragraphs that are preceded by the exclamation icon. Failure to comply with the information following an exclamation icon may result in injury to the user or permanent damage to the enclosure.
- Critical information is presented in boldface type in paragraphs that are preceded by the wrench icon. A trained certifier or contractor should only perform these operations. Failure to comply with the information following a wrench icon may result in injury to the user or permanent damage to your hood.
- Important information is presented in capitalized type in paragraphs that are preceded by the pointer icon. It is imperative that the information contained in these paragraphs be thoroughly read and understood by the user.

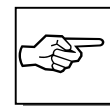

CHAPTER 2

PREREQUISITES

Before you install the Protector Demonstration Hood, you need to prepare your site for installation. Carefully examine the location where you intend to install the hood. You must be certain that the area is level and of solid construction. In addition, a dedicated source of electrical power should be located near the installation site to power the accessory FilterMate Portable Exhauster or other apparatus.

Carefully read this chapter to learn the requirements for your installation site:

- The support requirements.
- The location and air current requirements.
- The exhaust and blower requirements.
- The electrical power requirements.
- The space requirements.

Refer to *Appendix B: Dimensions* for complete Protector Demonstration Hood dimensions.

Refer to *Appendix C: Specifications* for complete electrical and environmental conditions, specifications and requirements.

Support Requirements

At a minimum, the supporting structure usually consists of a base cabinet, or a base stand and chemically-resistant work surface.

When setting up a chemical station, a mobile stand or cart is allowable. Labconco manufactures a mobile cart with work surface specifically designed to support the Protector Demonstration Hood and FilterMate Portable Exhauster. The cart is supplied with the Mobile Protector Demonstration Hood or can be ordered separately as an accessory. See Chapter 7 for accessories.

Location and Air Current Requirements

The Protector Demonstration Hood has been designed to contain hazards by negating typical cross drafts and movements within the opening. As a precautionary measure it is recommended that the enclosure be placed in such an area away from:

- High traffic areas where walking might cause an air disturbance.
- Overhead or wall HVAC diffusers, fans, radiators or other lab equipment producing air currents.
- Next to doorways or windows that may be opened.

Exhaust and Blower Requirements

The exhaust connection has been designed to accept a 2" x 10" (5.1cm x 25.4cm) nominal exhaust collar. The Protector Demonstration Hood has two possible exhaust connections with either the top exhaust open and the bottom exhaust closed or vice versa. The bottom exhaust connection is primarily used in installations where the hose or ductwork will be concealed. The bottom exhaust is used on the Mobile Protector Demonstration Hood to conceal the exhaust and facilitate connection to the FilterMate Portable Exhauster. Labconco offers accessory Transition Adapters for the top or bottom exhaust connection to either a 5" hose or 6" duct. (See Chapter 7 for ordering any of these accessories). Only one exhaust connection is required. The mobile Protector Demonstration Hood includes the lower 5" hose exhaust transition, FilterMate Portable Exhauster, 5" hose, mobile cart and work surface. Data for the exhaust volume and enclosure

static pressure loss are listed for each model at face velocities of 60, 80 and 100 fpm.

Demo Hood Width	Demo Hood Height	Model Description	Face Velocity (fpm)	Exhaust Volume (CFM)	Static Pressure Loss (in w.g..)
3'	22.75"	Demonstration Hood w/ 8" sash opening	60	110	.04"
			80	145	.06"
			100	185	.10"
3'	32"	Demonstration Hood w/ 10" sash opening	60	140	.06"
			80	185	.10"
			100	230	.15"

Proper blower selection can be determined from these exhaust requirements and the total system static pressure loss. The enclosure must be connected to either a dedicated blower, a house exhaust system or a dedicated filtered exhauster, such as a Labconco FilterMate Portable Exhauster.

Labconco offers three accessory remote blowers listed in Chapter 7.

Electrical Requirements

Standard duplex electrical receptacles should be nearby for connecting the Demonstration Hood, FilterMate Portable Exhauster, an airflow monitor, accessory Fluorescent Light or other equipment. For your convenience both the accessory FilterMate and accessory fluorescent light kit have auxiliary outlet receptacles. It is required that the airflow monitor be connected directly to the auxiliary switched outlet on the rear of the FilterMate so the airflow monitor is ON when the blower is ON. The FilterMate auxiliary switched outlet is rated for 8 amps.

For other blower exhaust systems, it is recommended that the airflow monitor be switched by the same circuit as the exhaust blower. If this is not possible, then the airflow monitor may be connected to the switched auxiliary outlet on the accessory fluorescent light kit. The fluorescent light kit auxiliary outlet can be used for any accessory under 8 amps.

Space Requirements

The dimensions for the different models are shown in *Appendix B: Dimensions*.

CHAPTER 3

GETTING STARTED

Now that the site for your Protector Demonstration Hood is properly prepared, you are ready to unpack, inspect, install, and validate your hood system. Read this chapter to learn how to:

- Unpack and move the hood.
- Set up the hood with the proper supporting structure and work surface.
- Connect to an exhaust system.
- Connect the electrical supply.
- Seal the hood to the work surface.
- Arrange validation for the enclosure.

Depending upon which model you are installing, you may need common plumbing and electrical installation tools in addition to wrenches, ratchets, sockets, a nut driver set, a flat-blade screwdriver, a Phillips screwdriver, and a carpenter level to complete the instructions in the chapter.



The hoods weigh either 100 or 120 lbs. each (45 to 54 kg). The shipping container allows for lifting with a mechanical lift truck or floor jack. If you must lift the hood manually, follow safe-lifting guidelines. Do not lift by the front air foil.

Unpacking the Hood

The United States Interstate Commerce Commission rules require that claims be filed with the delivery carrier within fifteen (15) days of delivery.

Carefully remove the shrink-wrap or carton on the hood and inspect it for damage that may have occurred in transit. If damaged, notify the delivery carrier immediately and retain the entire shipment intact for inspection by the carrier.

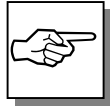

DO NOT RETURN GOODS WITHOUT THE PRIOR AUTHORIZATION OF LABCONCO. UNAUTHORIZED RETURNS WILL NOT BE ACCEPTED.

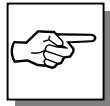

IF ENCLOSURE WAS DAMAGED IN TRANSIT, YOU MUST FILE A CLAIM DIRECTLY WITH THE FREIGHT CARRIER. LABCONCO CORPORATION AND ITS DEALERS ARE NOT RESPONSIBLE FOR SHIPPING DAMAGES.

Do not discard the packing material until you have checked all of the components and tested the unit.

We recommend that you do not remove the hood from its shipping container until it is ready to be placed into its final location. Move the unit by placing a flat, low dolly under the shipping skid, or by using a floor jack.



Do not move the hood by tilting it onto a hand truck.

Installing the Hood on a Supporting Structure and Work Surface

When installing the hood onto a chemically resistant work surface or benchtop, ensure that the structure can safely support the combined weight of the hood and any related equipment. The work surface should be at least as wide as the hood to properly support it. The front of the hood should be aligned within 1/8" of the front of the work surface. Mounting holes are provided in Labconco accessory work surfaces to secure the hood. The mobile Demonstration Hood features a work surface attached to the cart.

Work Surface Specifications

The work surface should be smooth, rigid, and durable, such as a chemically resistant epoxy resin. The surface should be non-porous and resistant to the acids, solvents and chemicals used in conjunction with the Protector Demonstration Hood. The work surface should also contain a dished recessed area for containing primary spills.

Work Surface and Hood Installation

1. Level the base cabinets and the work surface. Work surface should be placed flush with the front of the base cabinet as shown in Figure 3-1.
2. Position the work surface in its intended location and with the front of the work surface (wide flange) towards you.
3. Secure the work surface to the base cabinet with a structural adhesive or silicone sealant.
4. Insert the supplied mounting screws in the four holes. Allow a minimum of 1/8" clearance under the head of the screw for positioning the enclosure.
5. Place the hood on the work surface and slide the rear flange and front air foil flanges under the mounting screw heads.
6. Tighten the four screws to complete the installation.

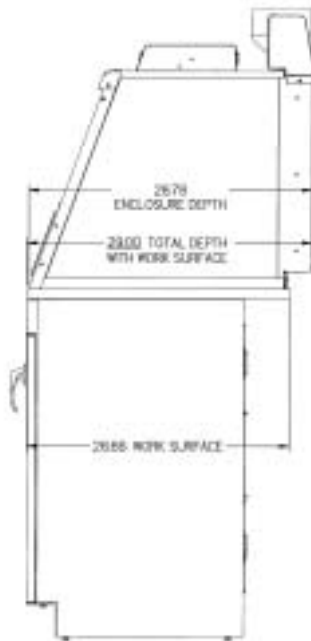

Side View of Typical Installation

Figure 3-1

Connecting to the Exhaust System



WARNING: The weight of the exhaust ductwork system must be supported independently of the superstructure or damage may occur.



The exhaust system should be installed by a qualified HVAC contractor.

The exhaust connection on the Demonstration Hood has been designed to accept a 2" x 10" (5.1cm x 25.4cm) nominal transition adapter. See Chapter 7 for ordering accessory transition adapters. Labconco manufactures transition adapters for either top or bottom exhaust and for both 5" dia. hose or 6" dia. duct. Review Chapter 2 for remote blower and FilterMate Portable Exhauster exhaust prerequisites and review Chapter 7 for ordering blower exhaust equipment. For your convenience several exhaust options are shown in Figures 3-2, 3-3, 3-4, 3-5 and 3-6. Consult Labconco Customer Service should you require help sizing your blower for the exhaust volume and system static pressure loss.

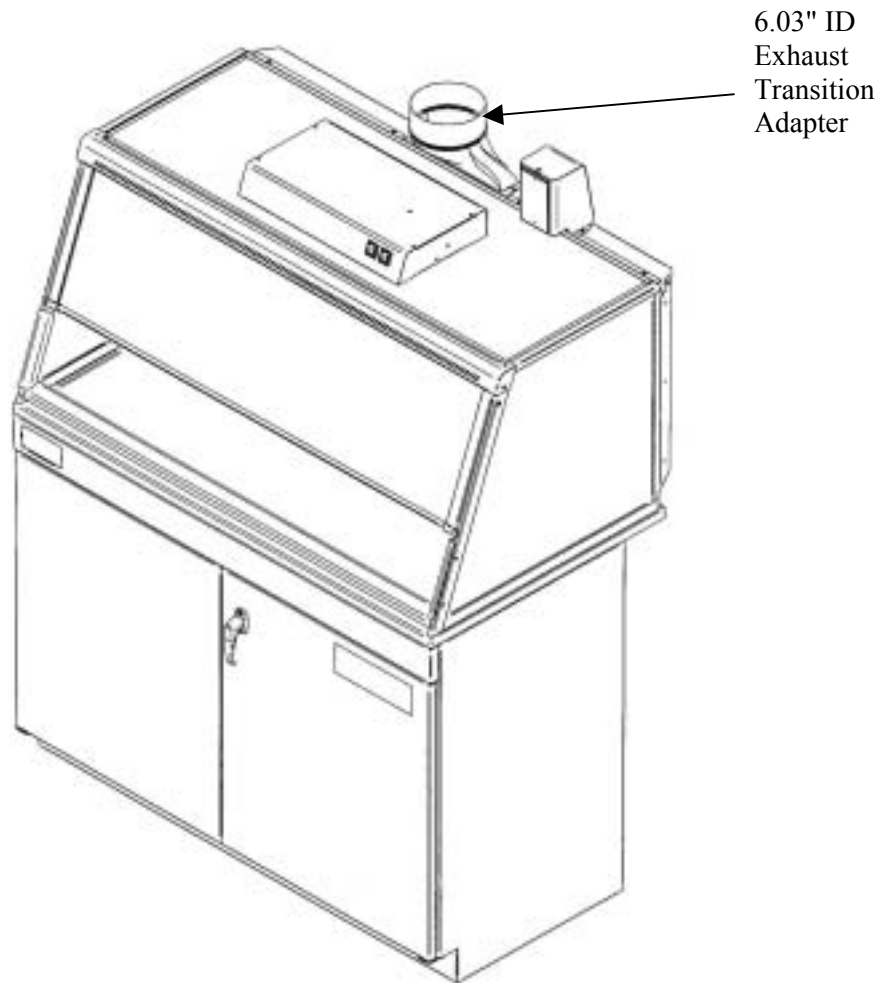

Figure 3-2 Top Connection to Outside Exhaust

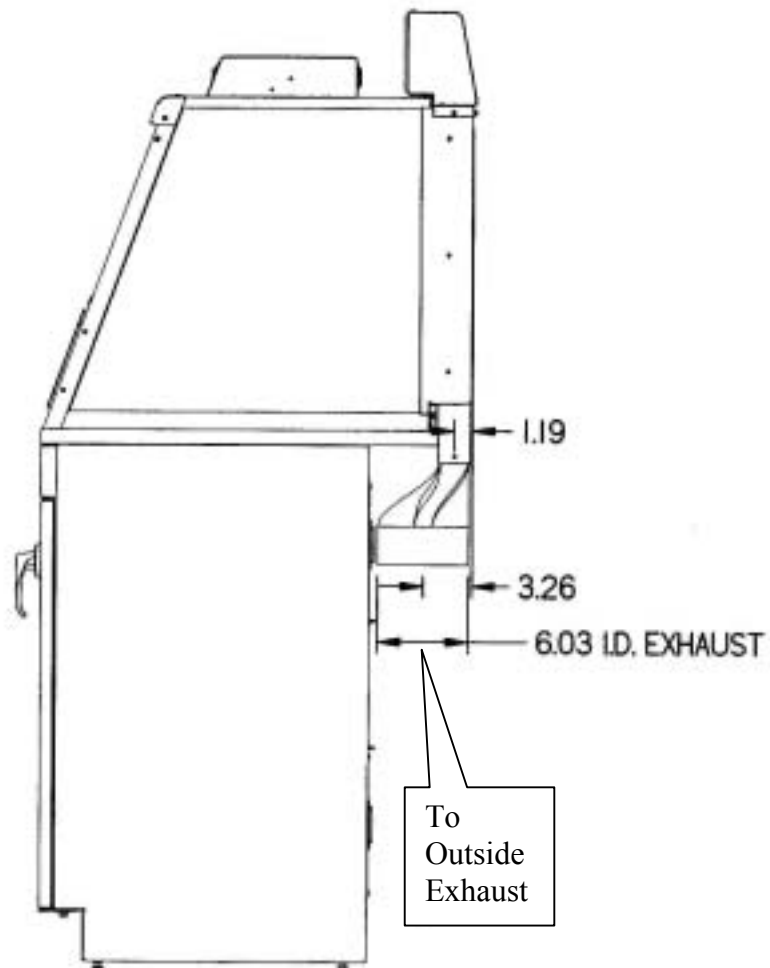

Figure 3-3
Side View of Bottom Connection to
Outside

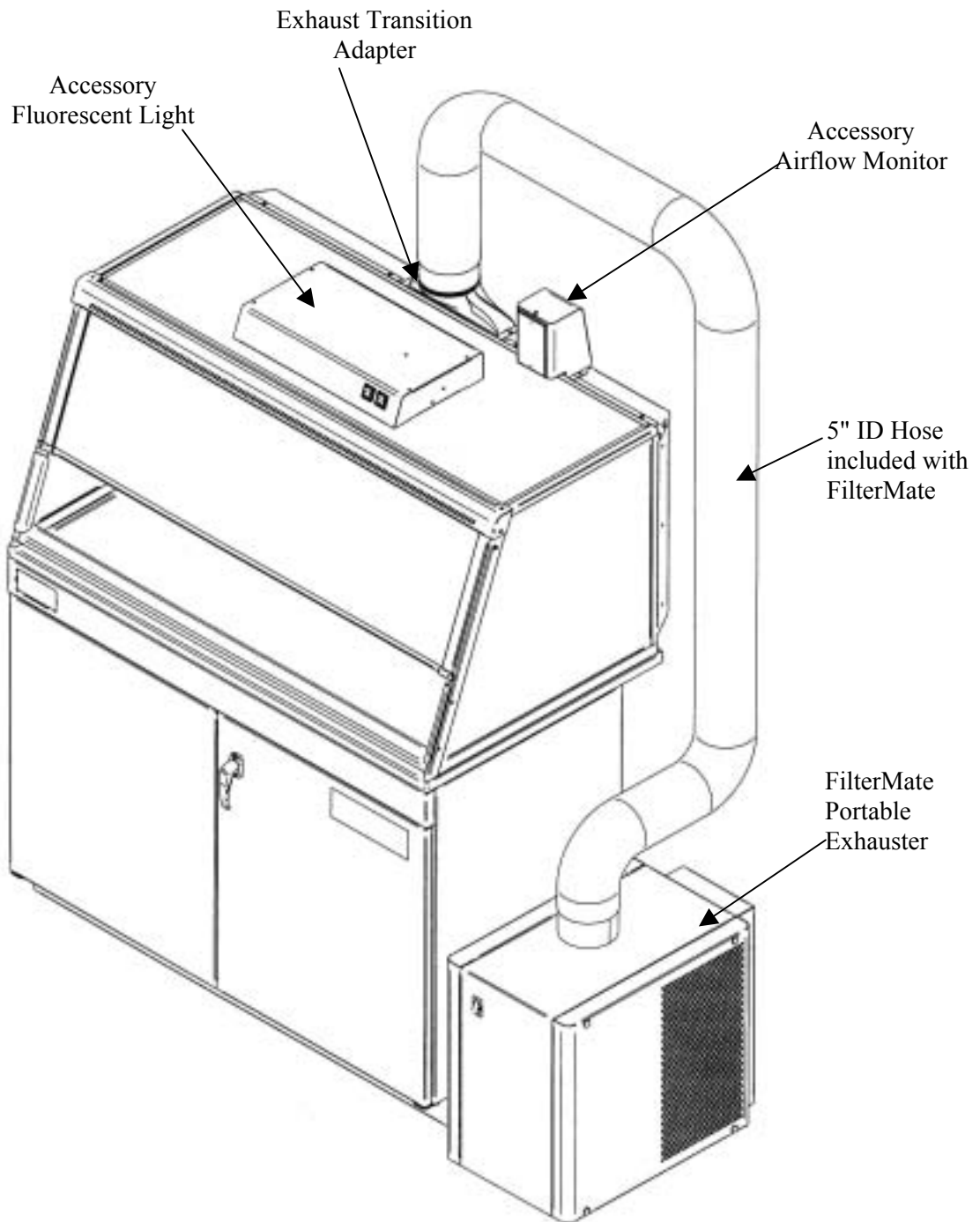

Figure 3-4
Top Connection to FilterMate Portable
Exhauster

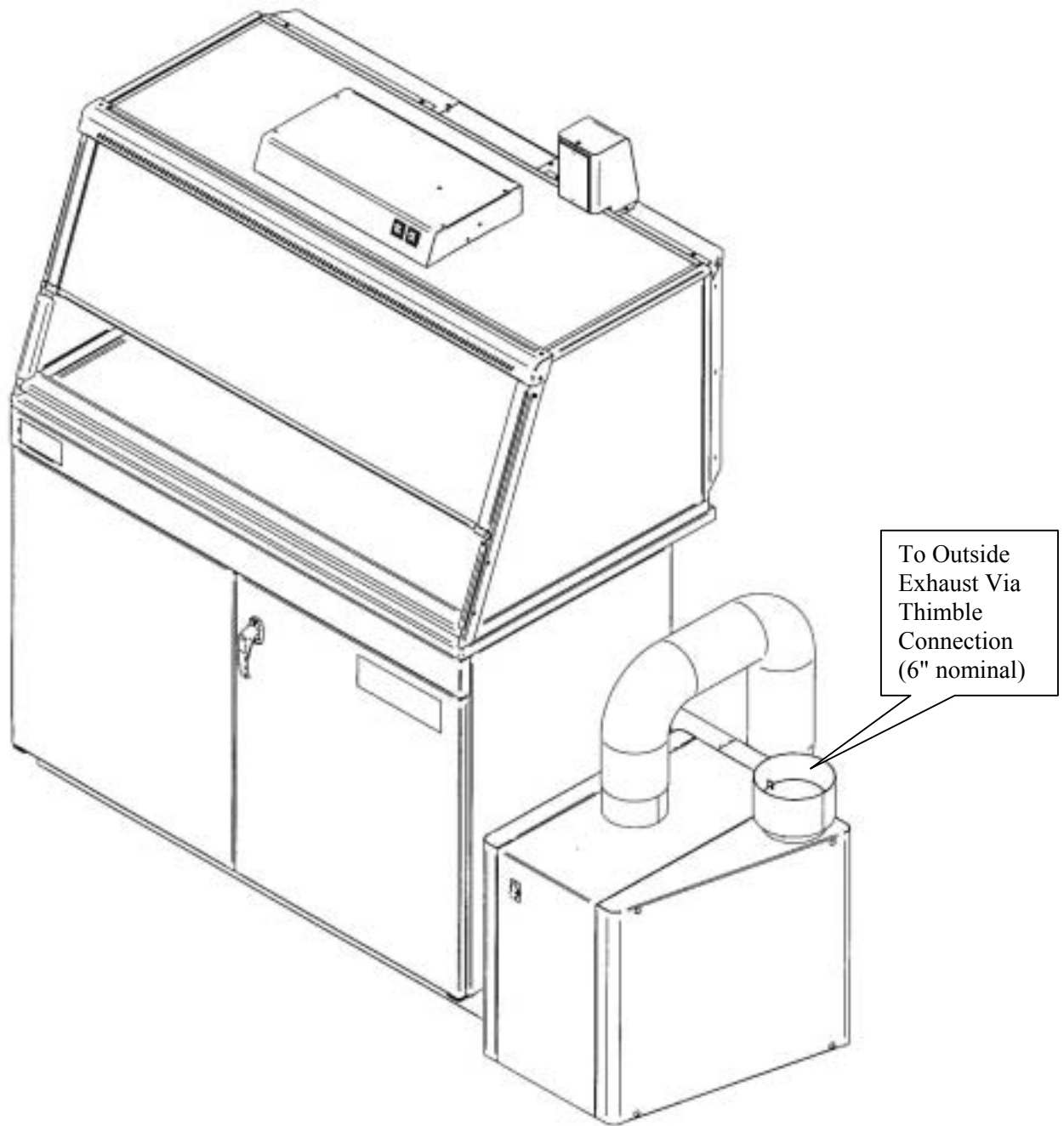

Figure 3-5
Bottom Connection to FilterMate
With Outside Thimble Exhaust Connection

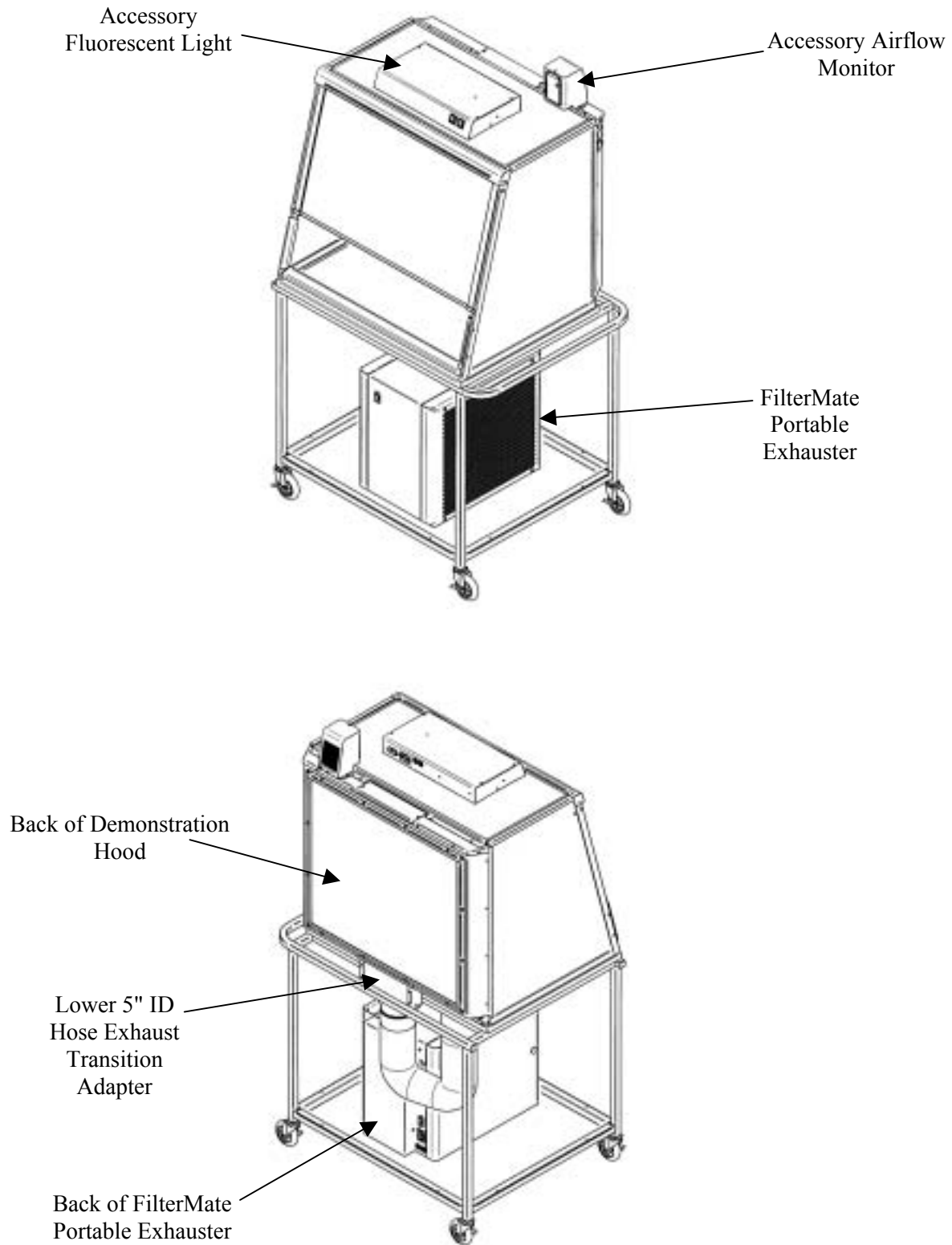

Figure 3-6
Connection to FilterMate on Mobile Cart

Connecting the Electrical Supply

A standard duplex receptacle should be nearby for connecting the FilterMate Portable Exhauster, airflow monitor and accessories. Please review Chapter 2 for electrical prerequisites.



All wiring for the building duplex outlets SHOULD be performed by a licensed electrician and conform to all local codes.

Sealing to the Work Surface

When the hood has been set in place, ducted and wired, it may be sealed at the work surface to prevent spilled materials from collecting under the walls. A bead of silicone sealant is recommended to seal the hood to the work surface.

Validating the Hood

The exhaust damper, exhaust blower or FilterMate gives you the flexibility to change the airflow at the sash opening of your enclosure. Determine the actual face velocity at the sash opening by taking airflow velocity readings. These should be taken across the sash opening of the enclosure in accordance with the *Industrial Ventilation Manual*. (See Appendix D) The “average face velocity” is achieved by taking readings in two rows across the enclosure with the readings 6" from the ends and evenly spaced every 12"; the first row is 3" down from the upper sash foil and the second row is 3" up from the work surface. Labconco recommends an average face velocity at the sash opening of 60 to 100 feet per minute for Protector Demonstration Hoods. Refer to Chapter 2 for proper airflow volumes for your particular model.

Your Protector Demonstration Hood has been tested at the factory per ASHRAE 110-1995. All enclosures achieve an “as manufactured rating” of less than 0.05 part per million (ppm) at 4 liters per minute (lpm); AM <0.05 (Consult Labconco for individual ratings). For “field use” ASHRAE testing contact Labconco for a certified on-site contractor.



NOTE: Face velocity profiles and smoke testing should be performed frequently per your organization’s quality system to ensure safe performance.

CHAPTER 4

HIGH PERFORMANCE FEATURES AND SAFETY PRECAUTIONS

High Performance Features:

The patented (U.S. Patent No. 6,461,233) Protector Demonstration Hood is designed to meet the needs of a variety of laboratory applications, and provide superior containment while conserving energy at OSHA approved “low flow” velocities as low as 60 feet per minute. The Protector Demonstration Hood has been designed to effectively contain toxic, noxious, or other harmful materials when properly installed and operated. What makes the Protector Demonstration Hood so unique is the revolutionary way it directs air into and through the contaminated air chamber. Labconco engineered the hood to minimize the effects of turbulence. The containment enhancing and aerodynamic designs of the upper sash foil, side air foils, lower air foil, upper dilution air supply, and rear baffle all work in concert to produce airflow patterns that significantly reduce both powder and chemical concentrations through the work area. The Protector Demonstration Hood incorporates unique 360° visibility, which is useful in laboratory demonstrations and visibility across classrooms.

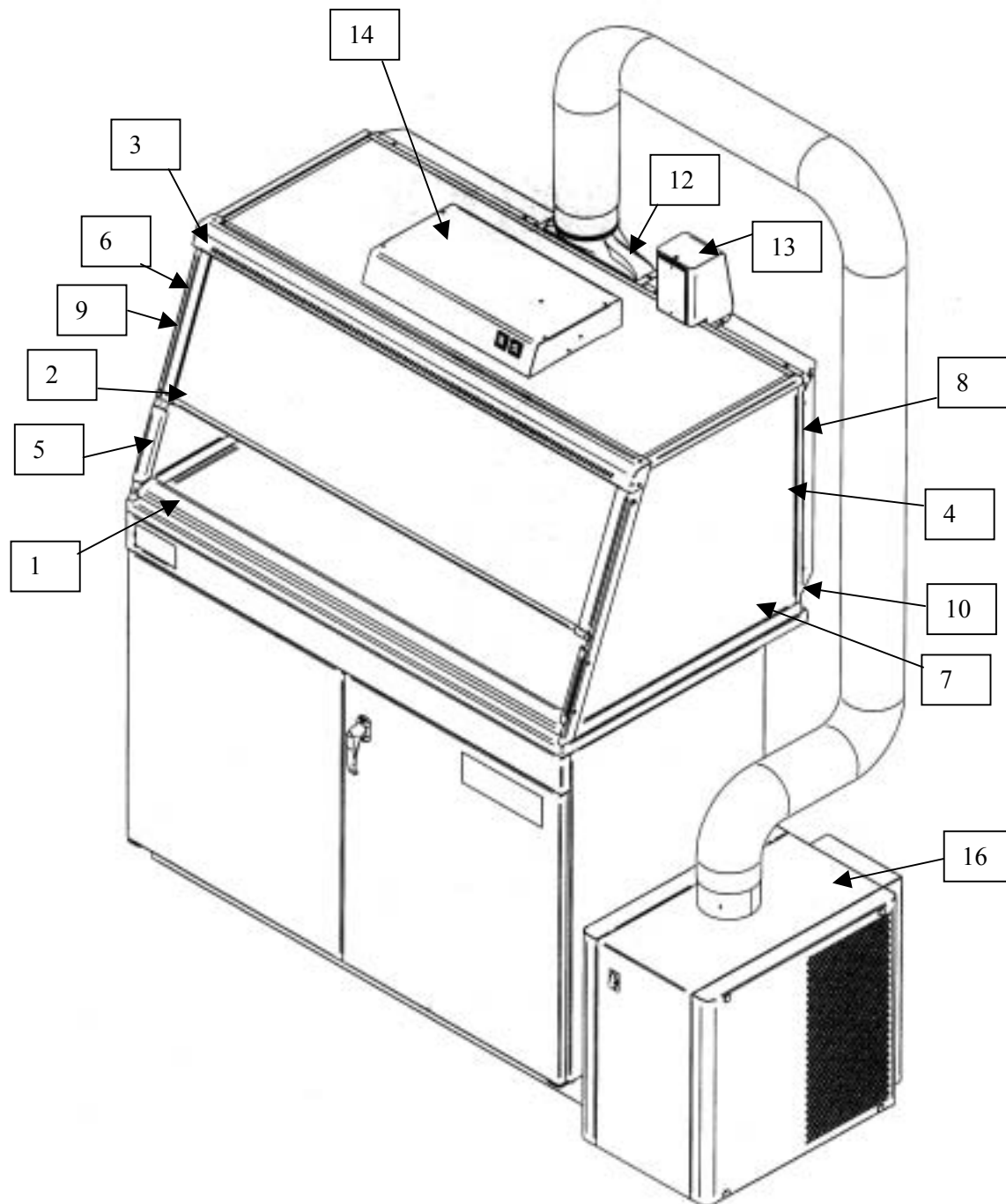
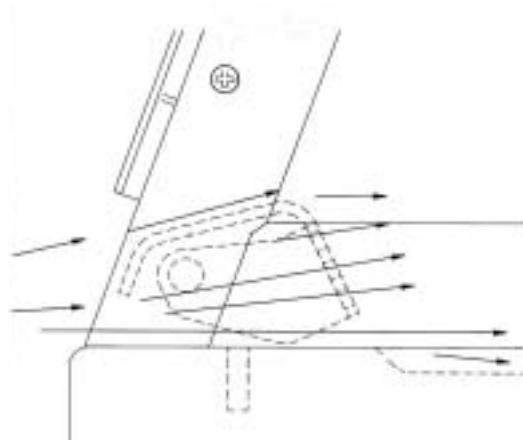

Figure 4-1

1. **Aerodynamic Clean-Sweep™ Air Foil** has a unique low profile shape that allows air to sweep the work surface for maximum containment. The Clean-Sweep™ openings create a constant protective barrier from contaminants. In addition, should the operator inadvertently block the airflow entering the air foil, air continues to pass under the air foil and through the Clean-Sweep openings. See Figure 4-2.

Figure 4-2



2. **Containment-Enhancing Upper Sash Foil** includes a perforated air passage directly atop the sash foil to bleed air into the hood chamber and direct chemical and powder concentrations away from the sash opening. The radiused sash foil sweeps airflow into the hood with minimal turbulence. See Figure 4-3.

Figure 4-3



3. **Upper Dilution Air Supply** provides bypass air from above the work area. This feature constantly bathes the sash interior with clean air and reduces powders and chemical fumes along the sash plane, near the critical breathing zone. Five to seven percent of the required air volume is introduced through the upper dilution air supply to ensure maximum containment. Additionally, the upper dilution air supply reduces stagnant pockets of air in the upper interior. See Figure 4-4.

Figure 4-4

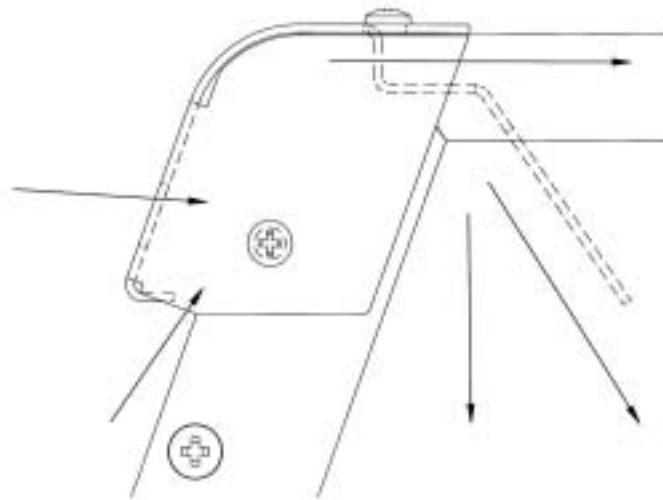

4. **Visible Clear Rear Baffle** directs air streams to the baffle in a single pass. The baffle and rear panel are manufactured from framed glass panels to provide maximum visibility on all sides. This smooth flow minimizes the potential for air to roll forward preventing contamination from moving toward the sash opening. The concentrations of materials are largely removed on the first pass through the contaminated chamber.
5. **Side Entry Air Foils** allow turbulence-free air to enter the hood from the sides and allow clean air to sweep the interior walls.
6. **Ergonomic Slope** provides maximum visibility, and comfort reduces glare, thereby minimizing operator fatigue.

7. **Internal Depth of 23"** provides necessary space to support equipment without extending outside the hood or resting on the lower air foil.
8. **Two Heights** available as standard enclosures in 22.75" or 32". Taller height Demonstration Hoods are typically used for pipet operations, titration or taller auxiliary equipment.
9. **Unique Flush Sash with Spring-Loaded Latch** has a wiping seal to contain contaminants and features a spring-loaded latch for loading auxiliary equipment. The sash pivots down for normal operation.
10. **Electrical Pass through Iris** allows electrical cords and data cords to pass through the back of hood without leaving a large hole for contaminants to escape. The hood ships with solid plugs and the iris plugs are included with the instruction manual for your convenience.
11. **Shipped fully assembled** to eliminate the need for costly onsite assembly. Accessories such as the exhaust transition connections, work surfaces, airflow monitors and fluorescent light kits are easily installed.
12. **Accessory Exhaust Connections.** The Protector Demonstration Hoods feature two exhaust locations: One is located on the top of the rear plenum and the other is located on the bottom of the rear plenum. The bottom exhaust incorporates a tissue screen to prevent debris from clogging the exhaust blower. Exhaust transition connectors are available for either a 6" OD outside exhaust or a 5" ID hose. All exhaust transition connectors are illustrated in Chapters 2 and 3 and accessories listed in Chapter 7. The lower 5" ID hose exhaust connection is used with the mobile cart for connection to the FilterMate Portable Exhauster which rests on the lower shelf.
13. **Accessory Guardian™ Airflow Monitor or Guardian Jr. Monitor** continuously monitors airflow. An audio/visual alarm alerts the user to low airflow conditions. The Guardian™ 1000 Digital Airflow Monitor also displays a face velocity value, provides an RS232 output, a night setback mode and several auxiliary relay ports. See Chapter 7 for ordering information.
14. **Accessory Fluorescent Light Kits** provide excellent illumination with an auxiliary outlet plug for supplying power to auxiliary equipment such as a balance or printer. See Chapter 7 for ordering information.

15. **Accessory Roof-Mounted Blower** sized to provide adequate airflow to Protector Demonstration Hoods when used with an exhaust damper. See Chapters 2, 3 and 7.
16. **Accessory FilterMate Portable Exhauster** provides up to 280 cfm for HEPA or Carbon filtration or up to 220 cfm for combination HEPA/Carbon filtration when connected to the hood. See Chapters 2, 3 and 7.
17. **Mobile Demonstration Hood** includes FilterMate Portable Exhauster, Demonstration Hood, work surface and mobile cart to allow easy transport throughout the facility. See Figure 3-6. Mobile cart can be ordered separately as shown in Chapter 7.

Safety Precautions



Although the hood has been engineered to maintain optimum operator safety, caution should always be used while working. Prior to using the hood, check to make sure that the exhaust blower is operating and that air is entering the hood at its specified face velocity. The use of an airflow monitor is recommended to alert the user if there is a problem with airflow.



Use good housekeeping in the hood at all times. Clean up spills immediately. Periodically clean enclosure interior.



Do not overload the work surface with apparatus or work material. The safe operation of the hood is based upon having proper airflow through the structure. Do not place large, bulky objects such as block heaters, directly on the work surface. Instead, elevate the object 3/4" on blocks to allow a flow of air under the object and into the rear baffle exhaust slots. Ensure blocks are level and secured in place.

Blocking large portions of the rear baffle will change the airflow pattern in the hood causing turbulence. (Do not store containers

or supplies against the rear baffle, as this will affect airflow).

Always work with your hands as far back in the hood as possible. It is best to keep all powders, chemicals and apparatus inside the lower air foil of the hood.



Do not work with chemicals in this hood without the exhaust system running.

Perchloric acid use in this hood is prohibited.



High-level radioisotope materials are prohibited in this hood.

Avoid cross drafts and limit traffic in front of the hood. Air disturbances created may draw contaminants out of the hood.

The hood should be tested by a qualified certification technician before it is initially used. The hood should be validated whenever it is relocated, serviced or at least annually thereafter.

The use of safety goggles, protective clothing, gloves and any other personal protective equipment recommended by your safety officer should be used.

The sash should remain in the down position while using the hood.

Proper operation of the hood depends largely upon its location and the operator's work habits. Consult the references in *Appendix D*.

CHAPTER 5

USING YOUR

PROTECTOR

DEMONSTRATION HOOD

Planning

- Thoroughly understand procedures and equipment required before beginning work.
- Arrange for minimal disruptions, such as room traffic or entry into the room while the hood is in use.

Start-up

- Turn on exhaust system and accessory light if so equipped.
- Only raise the sash for loading.
- Check the baffle air slots for obstructions.
- Allow the enclosure to operate unobstructed for 1 minute.
- Wear a long sleeved lab coat and rubber gloves. Use protective eyewear. Wear a protective mask if appropriate. Consult your Safety Officer for additional personal protective equipment recommendations.

Loading Materials and Equipment

- Only load the materials required for the procedure. Do not overload the hood.
- Do not obstruct the air foil, or rear baffle slots.
- Large objects should not be placed close together and should be elevated above the work surface to permit airflow to sweep under the equipment.

Work Techniques

- Keep all materials inside the lower air foil, and perform all contaminated operations as far to the rear of the work area as possible.
- Segregate all clean and contaminated materials in the work area.
- Avoid using techniques or procedures that disrupt the airflow patterns of the hood.

Final Purging

- Upon completion of work, the hood should be allowed to operate for two to three minutes undisturbed, to purge airborne contaminants from the work area before shutting down the blower.

Unloading Materials and Equipment

- Objects in contact with contaminated material should be surface decontaminated before removal from the hood.
- All open trays, weigh vessels or chemical containers should be covered before being removed from the hood.

Shutdown

- Turn off the exhaust system and accessory light if provided.

CHAPTER 6

MAINTAINING YOUR PROTECTOR DEMONSTRATION HOOD

Now that you have an understanding of how to work in the hood, we will review the suggested maintenance schedule and the common service operations necessary to maintain your hood for peak performance.



Only trained and experienced certification technicians should perform some of the service operations after the hood has been properly decontaminated. DO NOT attempt to perform these operations if you are not properly trained. The wrench icon precedes the service operations that require qualified technicians.

Routine Maintenance Schedule

Weekly

- Clean the hood interior appropriate for the application.
- Operate the exhaust system, noting the airflow velocity through the enclosure using a source of visible smoke. Airflow alarms are recommended for constant monitoring.

Monthly (or more often as required)

- Determine the actual face velocity through the sash opening of the hood where the average reading should be at the specified velocity. (Use calibrated thermal anemometer or other approved apparatus). Airflow alarms are recommended for constant monitoring.
- Using a cloth and glass cleaner, clean the exterior surfaces of the hood, particularly the front of the hood, to remove any accumulated dust.
- The hood rear baffle should be checked for any blockage to ensure that the enclosure is maintaining proper airflow.
- All weekly activities.

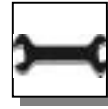

Annually

- Have the hood validated by a qualified certification technician. See Validating the Hood in *Chapter 3*.
- All monthly activities.



Calibration and Operation of Airflow Monitors

Guardian Jr. Airflow Monitor

The Guardian Jr. Airflow Monitor is designed to continuously monitor airflow through hoods. This permanently installed device provides both visual and audible alarms to alert the user of abnormal airflow conditions. A green light on the front of the monitor indicates normal flow conditions. When flow conditions lower than the set point are encountered, a red light is activated along with an audible alarm. A test button is provided at the front of the monitor to allow the user to check the operation of the alarm. To temporarily mute the audible alarm, press and release the test/reset button.

Guardian Jr. Component Identification

1. Air Inlet A portion of the air coming into the hood passes through the air inlet and across the flow sensors.
2. Normal Flow Indicator This green light indicates normal flow conditions.
3. Alarm Indicator This red light is activated approximately 6 seconds after the low flow set point is reached.
4. Test/Reset Button If no alarm is present, this button will cause the red lamp to light and the audible alarm to sound. If an alarm is present, the button will silence the audible alarm.
5. Adjustment for Alarm Set Point This potentiometer is used to set the low flow indicators for the alarm. It is adjusted with a small screwdriver.

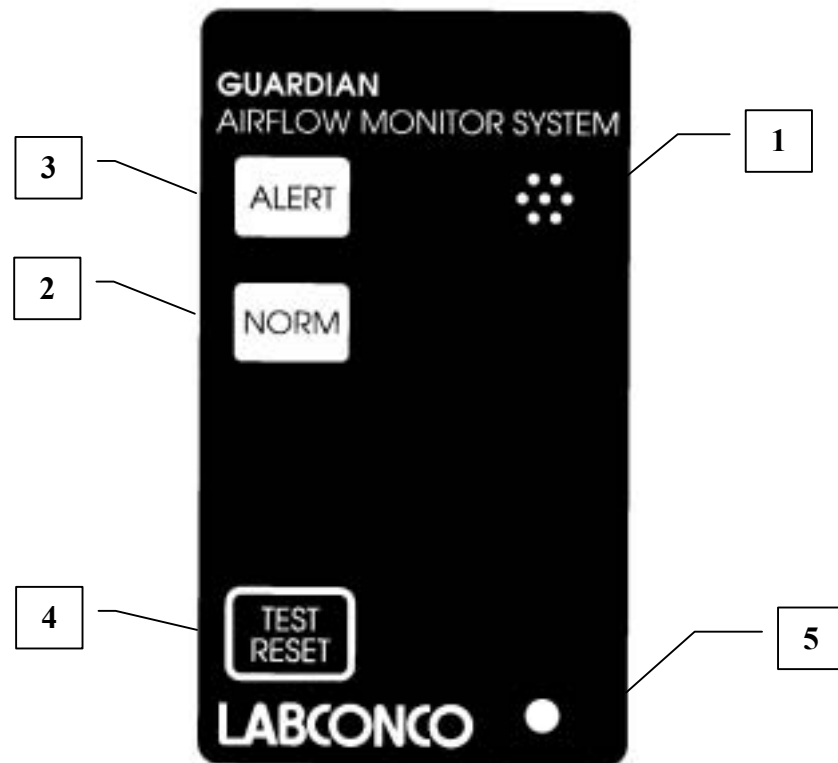

Figure 6-1
Guardian Jr. Components

Guardian Jr. Installation Procedure

1. The hood comes prepared to except the Guardian™ Jr. airflow monitor system.
2. First remove the small 0.50" dia. gray hole plug and two #8-32 x 0.50" self-tapping Phillips screws from the hood. Keep the screws for step 5. See Figure 6-2.

See Figure 6-3 for steps 3 through 9.

3. Open the top monitor cover by removing the two #8-32 x .38" lg. Phillips screws to access the tube stem and clear plastic tubing.
4. Temporarily remove the tube stem, Item 1 in Figure 6-3, and clear plastic tubing, Item 2.
5. Without the tube stem and clear plastic tubing attached, mount the Guardian Jr. alarm module to the hood with the two #8-32 x 0.50" screws removed in step 2.
6. Install the tube stem by tapping the non-serrated end of the tube stem into the 0.50" hole on the enclosure. Silicone sealant may be applied between the tube stem and the hood.
7. Route the clear plastic tubing without kinks between the rubber elbow tubing connector on the back of the Guardian Jr. alarm module and the tube stem. This completes the airway passage between the alarm module and the hood.
8. Locate the 9VDC power supply transformer, which should already be connected to the back of the alarm module through the strain relief bushing. If disconnected, then reconnect to the airflow monitor. Plug the 9VDC power supply into a 115V duplex receptacle, the back of the accessory FilterMate Portable Exhauster or the back of the accessory fluorescent light. For 230V, plug the power supply into an adapter or add an extension cable for connection to the FilterMate. **It is recommended that the airflow monitor be connected directly to the FilterMate switched auxiliary outlet so the airflow monitor is powered at the same time.**
9. Finish the installation by re-attaching the top monitor cover with two #8-32 x .38" lg. Phillips screws from step 3.

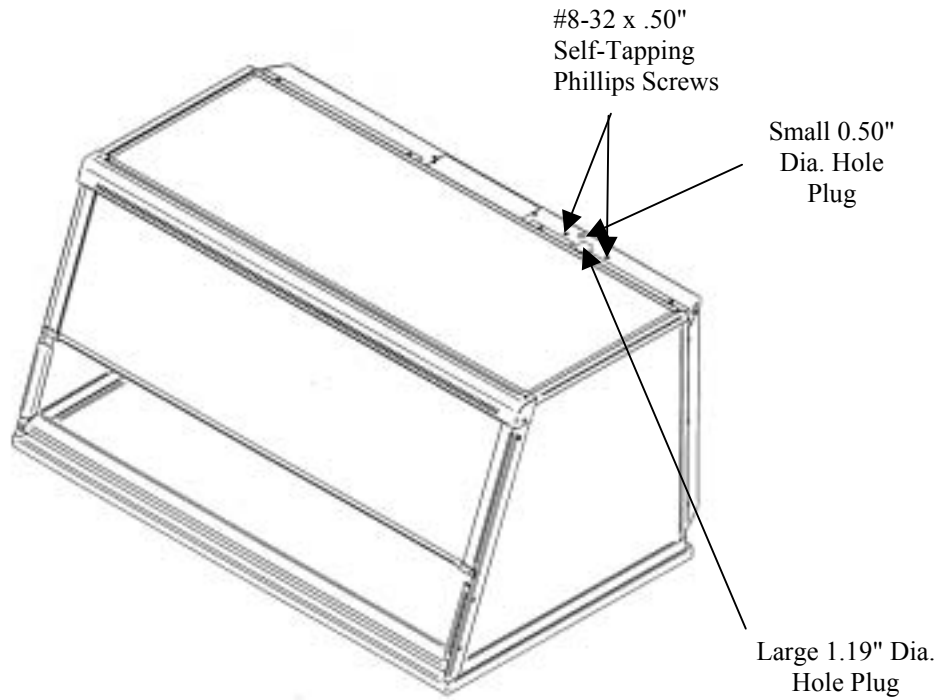

Figure 6-2
Hole Plug Location & Mounting Screws

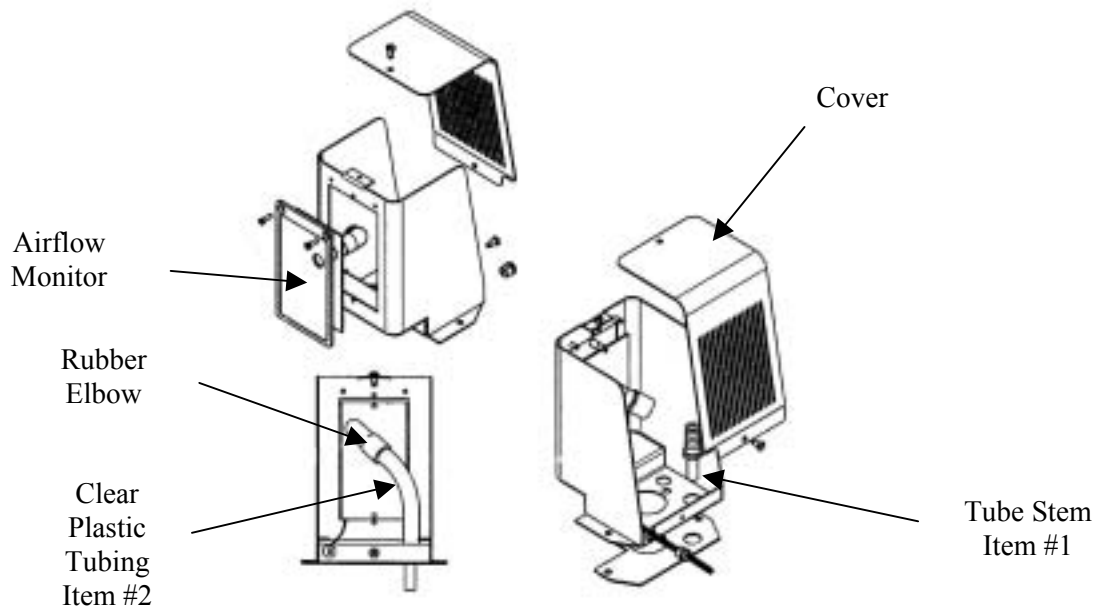

Figure 6-3
Guardian Jr. Details

Guardian Jr. Calibration Procedure

Each Guardian Jr., alarm module and hood is unique and needs to be individually calibrated in the field. The procedure for the adjustment is as follows:

1. Double check the installation instructions to make sure that monitor and power supply are properly installed.
2. Allow 10 minutes for the monitor to warm up once power has been connected.
3. Determine the low flow set point for your monitor. This is the value where the monitor will first indicate a low flow condition. The red light will be on for this value. Refer to your industrial hygiene officer for the proper low flow set point or consult the table to follow.
4. Adjust your hood airflow to the low flow set point as previously determined. The exhaust flow can be lowered by adjusting the speed control on the FilterMate or by using an adjustable damper on the exhaust blower. Typical alarm conditions are set at face velocities of 10 to 20 feet per minute below the normal operating conditions due to supply air and exhaust air fluctuations, as well as room air cross drafts.
5. Using a properly calibrated thermoanemometer, determine the velocity through the face of the hood by taking a detailed velocity traverse. Divide the face area into equal increments. One reading per square foot of face area is normally recommended for an accurate traverse. Compute the average velocity for this area.
6. If the red light alarm is on, slowly turn the adjustment screw counterclockwise until the green light is activated. If the green light is on, slowly turn the adjustment screw clockwise until the red light comes on. Slowly turn the adjustment screw back until the red light is activated. It is important that these adjustments be done in small increments, at intervals about 10 seconds apart to allow for delayed reaction of the alarm itself. The alarm low flow set point should now be set and the red light activated.
7. Readjust the hood airflow to its normal operating levels. The green light should now be activated.
8. Calibration is now complete.

Enclosure Operating In Flow Speed	Alarm Condition Set Point Speed
100 fpm	80 - 90 fpm
80 fpm	60 - 70 fpm
60 fpm	40 - 50 fpm

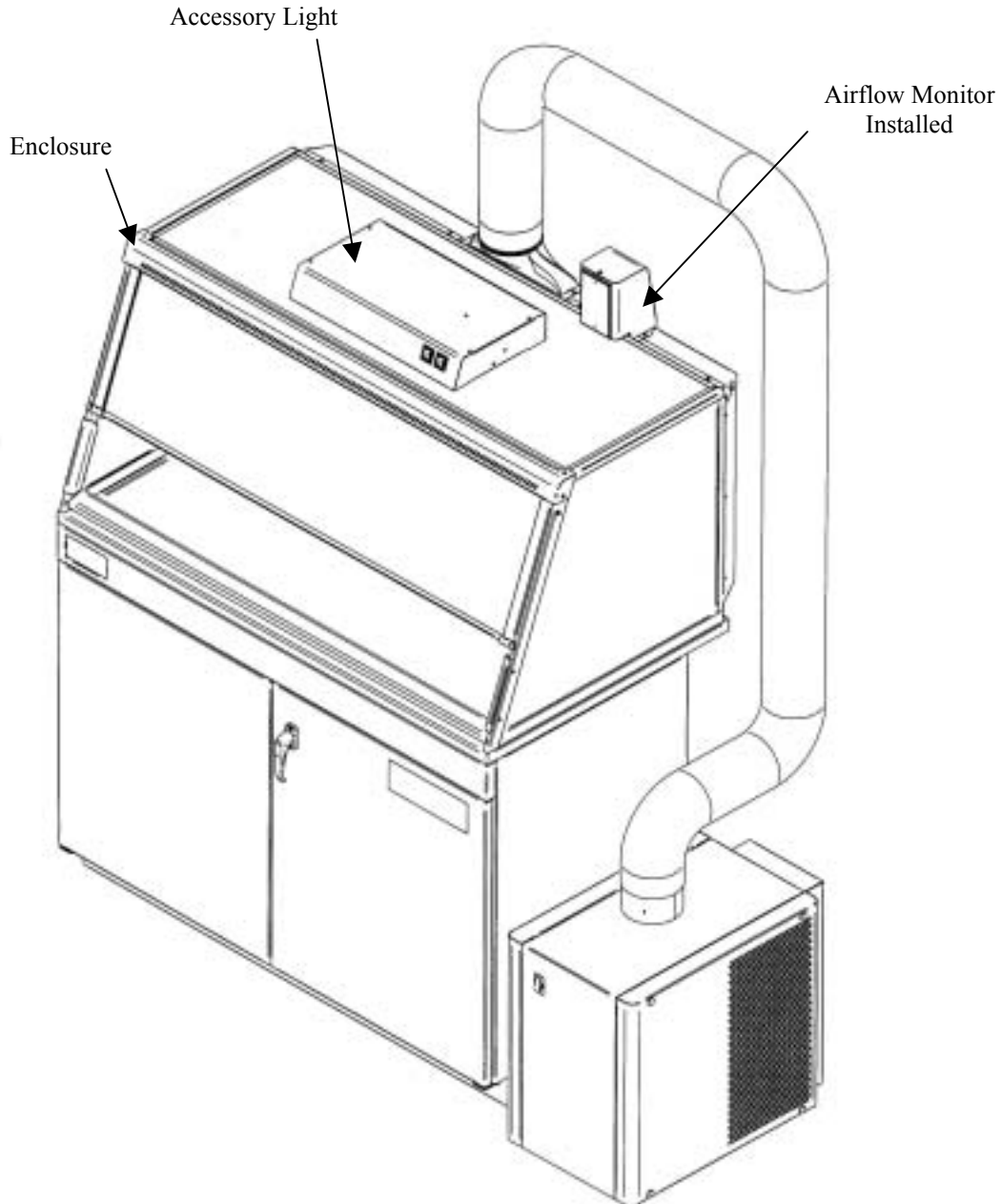

Figure 6-4
Guardian Jr., Installed

Guardian Jr. Alarm Activation

The audio and visual alarm will activate approximately six seconds after an alarm condition is detected. To temporarily mute the audible alarm, press and release the test/reset button.

NOTE: After an alarm condition has been detected, the red light will stay on. The audible alarm will remain muted until airflow returns to normal levels.

Guardian Jr. Alarm Test

When no alarm is present the alarm can be tested by pressing the test/reset button. While the button is pressed, the alarm light and audible alarm will be activated.

Guardian Digital 1000 Airflow Monitor Operation

The Guardian Digital Airflow Monitor consists of the airflow sensor, the alarm and the 15 VDC power supply. For 115V operation the alarm unit is powered by plugging the power supply into the factory-prepared digital airflow monitor socket. For 230V operation, the alarm is powered by plugging the power supply into a building outlet. The alarm has “Enter”, “+”, and “-” buttons to program the monitor. There is also a green LED “SAFE”, yellow LED “CAUTION”, and red LED “LOW” with audible alarm for airflow conditions. The audible alarm can be permanently muted if desired. The Guardian Digital 1000 Airflow Monitor displays a face velocity value, provides an RS232 communications port to a PC or building computer system, can be configured for external input connections such as night setback or external alarm and provides up to three output relays that can be configured. For complete detailed information, please refer to the separate Guardian 1000 Alarm User’s Manual provided with the enclosure.

Guardian Digital 1000 Installation Procedure

1. The hood comes prepared to except the Guardian 1000 Digital Airflow Monitor.
2. First remove the large 1.19" dia. gray hole plug and two #8-32 x 0.50" self-tapping Phillips screws from the hood. Keep

- the screws for step 3. See Figure 6-2. See Figure 6-5 only to reference internal assembly of the airflow monitor.
3. Secure the Guardian Digital Monitor to the enclosure with the two #8-32 x 0.50" screws removed from step 2.
 4. The airway passage between the alarm module and the hood is now complete.
 5. Locate the 15VDC power supply transformer. One end should already be connected to the two-pin connector labeled 15 VDC on the back of the alarm module and through the strain relief bushing. If disconnected, then reconnect to power the airflow monitor. Plug the 115V power supply into a 115V duplex receptacle, the back of the accessory FilterMate Portable Exhauster or the back of the accessory fluorescent light. For 230V, plug an adapter or add an extension cable for connection to the FilterMate. **It is recommended that the airflow monitor be connected directly to the FilterMate switched auxiliary outlet so the airflow monitor is powered at the same time.**
 6. Installation is now complete.

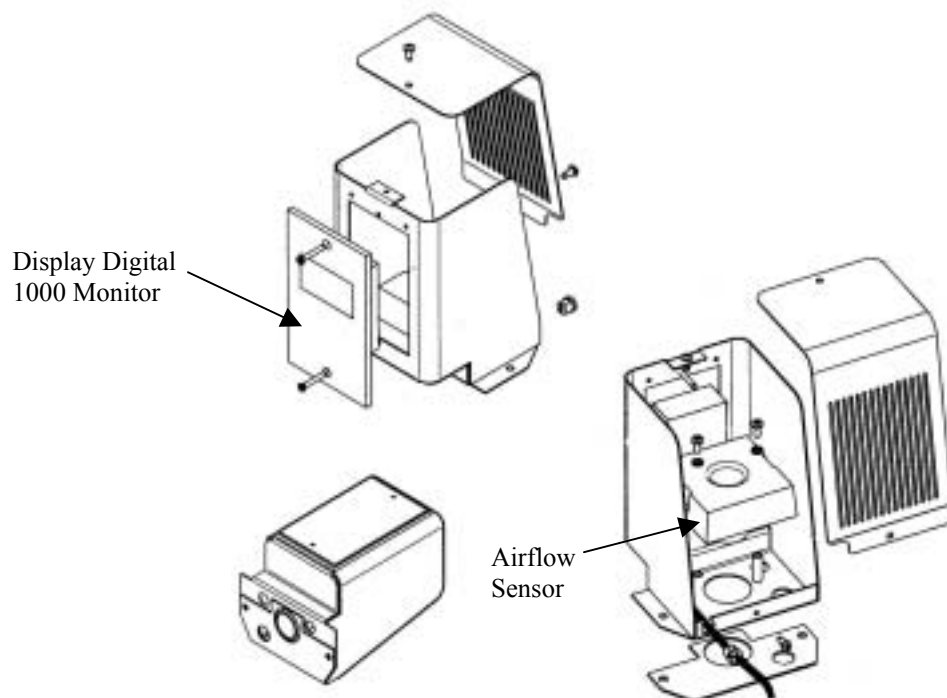

Figure 6-5
Guardian Digital 1000 Monitor Details

Guardian Digital 1000 Calibration

1. Calibrate the airflow monitor according to the monitor User's Manual that comes with the kit and follow the instructions below. To successfully calibrate, it will be necessary to change the face velocity by adjusting the airflow exhaust volume. The exhaust volume can be adjusted with the speed control on the FilterMate or by using an adjustable damper on the exhaust blower. Typical calibration conditions are set at face velocity air sample differences of at least 20 feet per minute. The airflow monitor is factory set to be calibrated with a difference of at least 50 fpm and can be changed by changing the "lower/higher air sample difference." The following suggested in flow face velocity speeds are recommended to successfully calibrate. Typical low air alarms are set 10-20 fpm below operational speeds. Follow Step 2 below and review the Guardian 1000 Alarm User's Manual that comes with the airflow monitor.

Low Air Alarm Set Point	Enclosure Operating Inflow Speed	Low Calibration Set Point	High Calibration Set Point
40 - 50 fpm	60 fpm	40 - 60 fpm	100 – 120 fpm
60 - 70 fpm	80 fpm	50 - 90 fpm	100 – 150 fpm
80 – 90 fpm	100 fpm	50 – 110 fpm	100 – 170 fpm

2. Go to SETUP menu and then CAL CONFIG MENU and change the "lower/higher air sample difference" to 20 fpm. This will allow you to successfully calibrate with values of a minimum of 20 fpm difference.
3. While in CAL CONFIG MENU, change the "sensor difference" from 10% to 3%.
4. While in CAL CONFIG MENU, adjust the red low air alarm to the desired setting such as 60 fpm. Then adjust the yellow "CAUTION or WARNING" to 63 fpm, if desired. Then adjust the "CAUTION or WARNING" air reset to 3 fpm. This sets the alarm condition.
5. To complete the CAL CONFIGURATION, be sure to enter "DONE".

6. To start the calibration mode, use the Guardian Digital 1000 Monitor User's Manual and enter "CALIBRATION" mode on the display from the SETUP menu.
7. Follow the instructions on the display and alter the low exhaust volume with the speed control on the FilterMate or exhaust damper. Measure the average face velocity and enter the low value on the display. Be careful not to block the opening. The low exhaust volume calibration will take about 5 seconds.
8. Now alter the high exhaust volume with the speed control on the FilterMate or exhaust damper. Measure the average face velocity and enter the high value on the display. The high value must be at least 20 fpm greater than the low value. The high exhaust volume calibration will take about 5 seconds.
9. Enter "DONE" after successfully completing the low and high calibration set points.
10. Once calibration is completed, go to "RUN" and press "ENTER". The value should read close to the high calibration set point.
11. To lower the face velocity to the operating point, simply alter the exhaust volume with the speed control on the FilterMate or exhaust damper. Then recheck the face velocity with an anemometer to confirm the display on the digital airflow monitor.

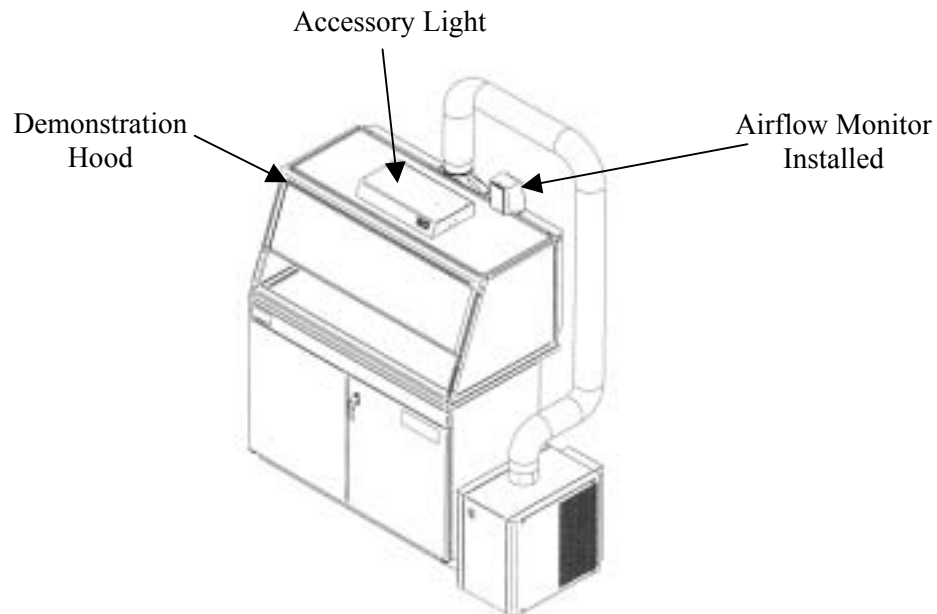

Figure 6-6
Guardian Digital 1000 Monitor Installed on Demonstration Hood

CHAPTER 7

ACCESSORIZING YOUR

PROTECTOR

DEMONSTRATION HOOD

There are several ways to accessorize the hood for your individual requirements. These include the addition of accessory work surfaces, airflow monitors, fluorescent lights, exhaust transition adapters, hoses, remote blowers, exhaust dampers, FilterMate Portable Exhausters, filters, storage cabinets and mobile carts.

Optional Equipment for the Demonstration Hood

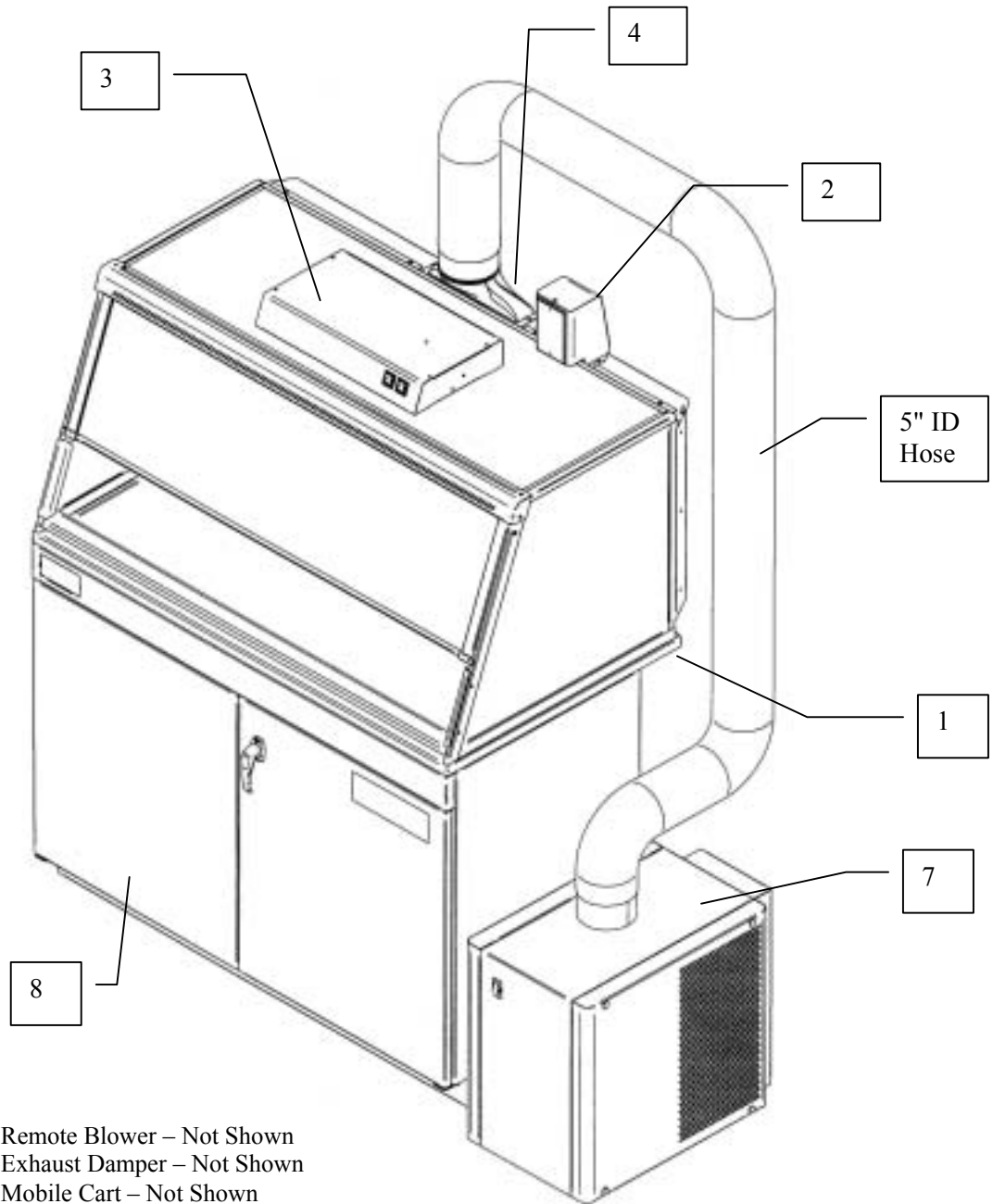

Figure 7-1

1. Work Surfaces



An optional dished work surface is available to attach to the hood.

Dished work surfaces are contoured to fit the dimensions of the hood to contain spills. Epoxy is chemical-resistant.

Catalog #	Description	Dimensions (W x D x H)
3908402	Black, 4-foot wide	48" x 26.66" x 1"
3908405	Gray, 4-foot wide	48" x 26.66" x 1"

2. Guardian™ Digital 1000 and Guardian™ Jr. Airflow Monitors



The Guardian Digital 1000 Airflow Monitor or Guardian Jr. Airflow Monitor allows you to continuously monitor airflow through the hood. The rear exhaust plenum is factory prepared to mount either monitor.

Catalog #	Description
3908700	Guardian Jr. Airflow Monitor, 115V, 60 Hz
3908701	Guardian Jr. Airflow Monitor, 230V, 50 Hz
3908800	Guardian Digital 1000 Airflow Monitor 115V, 60 Hz
3908801	Guardian Digital 1000 Airflow Monitor 230V, 50 Hz

3. Fluorescent Lights

A fluorescent light, which rests on the top of the hood, is available.

Catalog #	Description
3909200	18.25" W x 10.12"D x 3.00" H Light, 115V, 60 Hz
3909201	18.25" W x 10.12"D x 3.00" H Light, 230V, 50 Hz

4. Exhaust Transition Adapters

Adapter connects to the hood from either the top or the bottom of the rear plenum so the duct can be routed either up or down, respectively. The transition is available for either 5.00" ID hose or 6" OD duct. The 5.00" ID hose lower connection is included with the FilterMate supplied with the mobile cart.

Catalog #	Description	Material
3912400	Upper connection, 5" Hose	Epoxy-Coated Steel
3912401	Upper connection, 6" Duct	Epoxy-Coated Steel
3912402	Lower connection, 5" Hose	Epoxy-Coated Steel
3912403	Lower connection, 6" Duct	Epoxy-Coated Steel

5. Remote Blowers

Has a 1/4 hp direct drive motor and corrosion-resistant phenolic coated-steel housing and wheel with blower inlet of 6.00" ID. Outlet dimensions are 4.25" x 7.38" OD.

CFM @ Static Pressure-Inches of H ₂ O						
S.P.	0.0"	0.125"	0.25"	0.50"	0.75"	0.87"
CFM	595	560	515	420	300	167

Catalog #	Description	Shipping Wt. (lbs./kg.)
4863500	Remote Blower, 115 V, 60 Hz, 4.4 amps	35/16
4863501	Remote Blower, 115/230 V, 50 Hz, 5.6/2.8 amps	35/16
7053501	Explosion-Proof Remote Blower, 115 V, 60 Hz, 4.4 amps	40/18

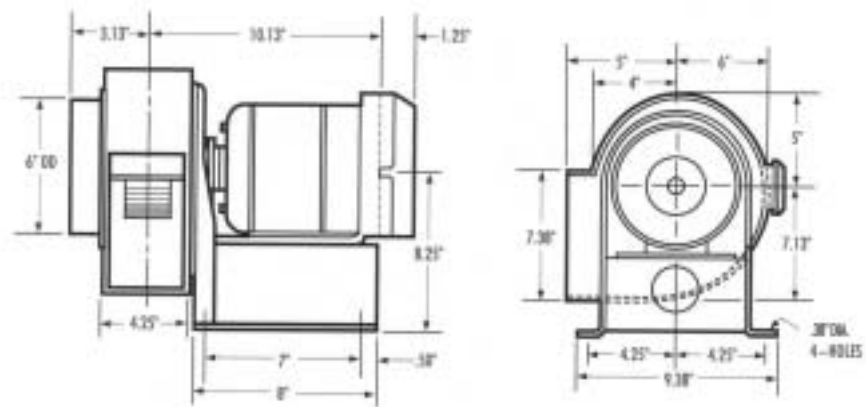

6. Exhaust Dampers

Exhaust dampers allow an adjustment required to maintain proper airflow for roof-mounted blowers or house exhaust systems.

Catalog #	Description
3924000	6" Epoxy-Coated Steel In-Line Adjustable Damper
4724200	6" PVC In-Line Adjustable Damper

7. FilterMate Portable Exhausters and Filters

For filtered exhaust, Labconco offers FilterMate Portable Exhausters capable of exhausting up to 280 cfm of HEPA filtered air or up to 220 cfm of combination Dual Carbon or HEPA/Carbon filtered air when connected to the enclosure.

Catalog #	Voltage	Filter	Exhaust Connection	Exhaust Airflow (cfm)
3970000	115 Volt/60 Hz	HEPA	None	280
3970001	115 Volt/60 Hz	Carbon	None	280
3970002	115 Volt/60 Hz	HEPA	Thimble to outside	280
3970003	115 Volt/60 Hz	HEPA/Carbon	None	220
3970004	115 Volt/60 Hz	Carbon/Carbon	None	220*
3970020	230 Volt/50 Hz	HEPA	None	280
3970021	230 Volt/50 Hz	Carbon	None	280
3970022	230 Volt/50 Hz	HEPA	Thimble to outside	280
3970023	230 Volt/50 Hz	HEPA/Carbon	None	220
3970024	230 Volt/50 Hz	Carbon/Carbon	None	220*

*Indicates model supplied with mobile cart with lower 5" exhaust transition included.

HEPA Filter - 3707900

99.99% efficient on particles 0.3 micron.

HEPA Filter Bag-In/Bag-Out Bag - 3776002

Helps contain hazardous particulate matter during filter changing operations.

Carbon Filter

Provides granular activated carbon or impregnated carbon.

Filter Classification	Catalog #	x Pounds
Organic	3923400	12.0 lbs activated carbon
Formaldehyde	3923401	14.0 lbs impregnated carbon
Ammonia	3923402	16.0 lbs impregnated carbon

8. Storage Cabinets

Size/Description	SOLVENT			ACID		
	Dual Doors	Right Hinge	Left Hinge	Dual Doors	Right Hinge	Left Hinge
48"	9902000	-	-	9901000	-	-
36"	9902100	-	-	9901100	-	-
30"	9902200	-	-	9901200	-	-
24"	-	9902300	9902400	-	9901300	9901500
18"	-	-	-	-	9901400	9901600
12"	-	-	-	-	-	-
48" w/Self Closing Doors	9903000	-	-	-	-	-
36" w/Self Closing Doors	9903100	-	-	-	-	-
30" w/Self Closing Doors	9903200	-	-	-	-	-
24" w/Self Closing Doors	-	9903300	9903400	-	-	-
24" ADA	-	9906000	9906100	-	9905000	9905200
24" ADA w/Self Closing Doors	-	9906200	9906300	-	-	-
18" ADA	-	-	-	-	9905100	9905300
12" ADA	-	-	-	-	-	-

Size/Description	STANDARD BASE			VACUUM PUMP		
	Dual Doors	Right Hinge	Left Hinge	Dual Doors	Right Hinge	Left Hinge
48"	9900000	-	-	-	-	-
36"	9900100	-	-	-	-	-
30"	9900200	-	-	-	-	-
24"	-	9900300	9900600	-	-	-
18"	-	9900400	9900700	-	9907000	9907100
12"	-	9900500	9900800	-	-	-
48" w/Self Closing Doors	-	-	-	-	-	-
36" w/Self Closing Doors	-	-	-	-	-	-
30" w/Self Closing Doors	-	-	-	-	-	-
24" w/Self Closing Doors	-	-	-	-	-	-
24" ADA	-	9904000	9904300	-	-	-
24" ADA w/Self Closing Doors	-	-	-	-	-	-
18" ADA	-	9904100	9904400	-	-	-
12" ADA	-	9904200	9904500	-	-	-

9. Mobile Cart 8026000

Provides a mobile cart and dished solid epoxy work surface for supporting the Protector Demonstration Hood.



10. Hoses, Hose Clamps, and Hose Kits

Provides alternatives for ducting.

Catalog #	Description
4868600	8 Feet of 5" ID gray flexible polypropylene hose (included with FilterMate). General purpose chemical-resistant hose suitable in pharmaceutical applications.
1921000	5" T-Bolt Hose Clamp (two included with FilterMate)
3927500	8 Feet of 5" ID clear smooth bore static dissipation hose with two hose clamps. Suitable in clean rooms or pharmaceutical applications.
3927600	8 Feet of 6" ID black thermoplastic hose with two 6.09" ID cuffs. Include two 6" hose clamps. Suitable for connection to house exhaust in pharmaceutical applications.
1921500	6" T-Bolt Hose Clamp

CHAPTER 8

TROUBLESHOOTING

Refer to the following table if your Protector Demonstration Hood fails to operate properly. If the suggested corrective actions do not solve your problem, contact Labconco for additional assistance.

PROBLEM	CAUSE	CORRECTIVE ACTION
Contaminants outside of enclosure	Improper user techniques for the enclosure.	See “Certifying the Hood” Chapter 3 and “Safety Precautions” Chapter 4 sections in the manual. (Ref. Appendix D)
	Restriction of the baffle air slots or blockage of the exhaust outlet.	Remove obstruction to ensure that all air slots and the exhaust outlet are unobstructed.
	External factors are disrupting the hood airflow patterns or acting as a source of contamination.	See “Location Requirements” Chapter 2, “Certifying the Hood” Chapter 3, and “Safety Precautions” Chapter 4 sections of this manual. (Ref. Appendix D)
	Hood has improper face velocity.	Have hood certified and check exhaust system. Check FilterMate filters for loading. Adjust FilterMate speed control. Hood should have average face velocity of 60-100 fpm.

PROBLEM	CAUSE	CORRECTIVE ACTION
Airflow monitor malfunction.	No power. No lights. No display.	Power supply is not plugged into proper voltage; plug in power supply. Verify that airflow monitor interface cables are connected. Check fuses on FilterMate or accessory light.
	No audible alarm.	Alarm has been temporarily silenced using “test/reset” or “enter” buttons.
	Wrong alarm set point.	Airflow monitor was not properly adjusted. Repeat calibration steps outlined in the airflow monitor manual.
	Constant audible alarm.	Check airflow and calibration of airflow monitor.
	Continuous alarm.	Check the face velocity of the enclosure as the airflow may have changed. If face velocity is correct, calibrate the airflow monitor as outlined in the User’s Manual.
	Monitor alarms; air way to airflow monitor sensor is blocked by insects, dust or debris.	Lightly clean the airway with clean air. Be careful not to touch sensitive electrical components.
	Audible disable will not stay ON	An alarm condition must be continuously present before the audible alarm can be silenced. If flow conditions fluctuate near the alarm set point, the airflow monitor will automatically reset itself. Action should be taken to bring the hood airflow into proper operating parameters or adjust the alarm set point lower.

APPENDIX A

REPLACEMENT PARTS

The following illustrations indicate the replacement parts.

Item	Qty.	Part Number	Description
1A	1	3906500	Glass, Side Short
1B	1	3926500	Glass, Side Tall
2	1	3906801	Glass, Top 3'
3A	1	3906101	Glass, Sash 3' Short
3B	1	3926101	Glass, Sash 3' Tall
4	1	3907601	Foil, Sash 3'
5	2.3 Ft.	6913700	Wiper, Sash
6A	1	3907500	Stop, Right Sash
6B	1	3907501	Stop, Left Sash
7A	1	1927403	Spring, Compression Sash Latch
7B	1	3906700	Latch Bracket
7C	1	6916500	Latch Sash
7D	2	1893206	Screw, #8-32 x .38 Phil, SS, Type F
7E	1	6916501	Latch Sash Tall
7F	1	3925300	Latch Bracket Tall
8A	1	3905201	Sash Assembly 3', Short
8B	1	3925201	Sash Assembly 3' Tall
9A	1	3907400	Bracket, Air Foil Right
9B	1	3907401	Bracket, Air Foil Left
9C	2	1932401	Washer, Shoulder Plastic
9D	2	1912108	Washer, .194 ID x .38 OD x .03 thick plastic
9E	2	1909217	Cap Nut #10-24 SS
10	1	3905601	Air Foil 3'
11	1	3905301	Header 3'
12	1	3913100	Cover Plate, Exhaust (Top or Bottom)
13A	1	3912400	Upper Exhaust Transition 5" Hose
13B	1	3912401	Upper Exhaust Transition 6" Duct
13C	1	3912402	Lower Exhaust Transition 5" Hose
13D	1	3912403	Lower Exhaust Transition 6" Duct
14A	1	1934601	Bushing, Heyco with Flex Shutter 1.50 dia.
14B	1	1936800	Bushing, Heyco Closed 1.50 dia.
15A	2	7868402	Spacer Bushing
15B	2	1912108	Washer, .194 ID x .38 OD x .03 T. Plastic
15C	2	1889316	Screw, #10-24 x 1.00 PH. (SS)
16A	2	3915400	Side Air Foil, Short
16B	2	3915401	Side Air Foil, Tall
16C	4	1889912	Screw, 6-32 x .75 PH. Type F, Oval Head
17	1	1595619	Hole Plug, .500 dia. Gray
18	1	1595621	Hole Plug, 1.187 dia. Gray
19	1	3941900	Label, Protector Demonstration Hood

Item	Qty.	Part Number	Description
20A	1	3942500	Baffle Assy, Short
20B	1	3941700	Baffle Assy, Tall
20C	2	1914200	Captive Screw, Baffle
20D	2	1923900	Receptacle, Clip-on
21	1	3943000	Shelf, Demo Cart
22	4	8009501	Caster 4" w/ Brake Demo Cart

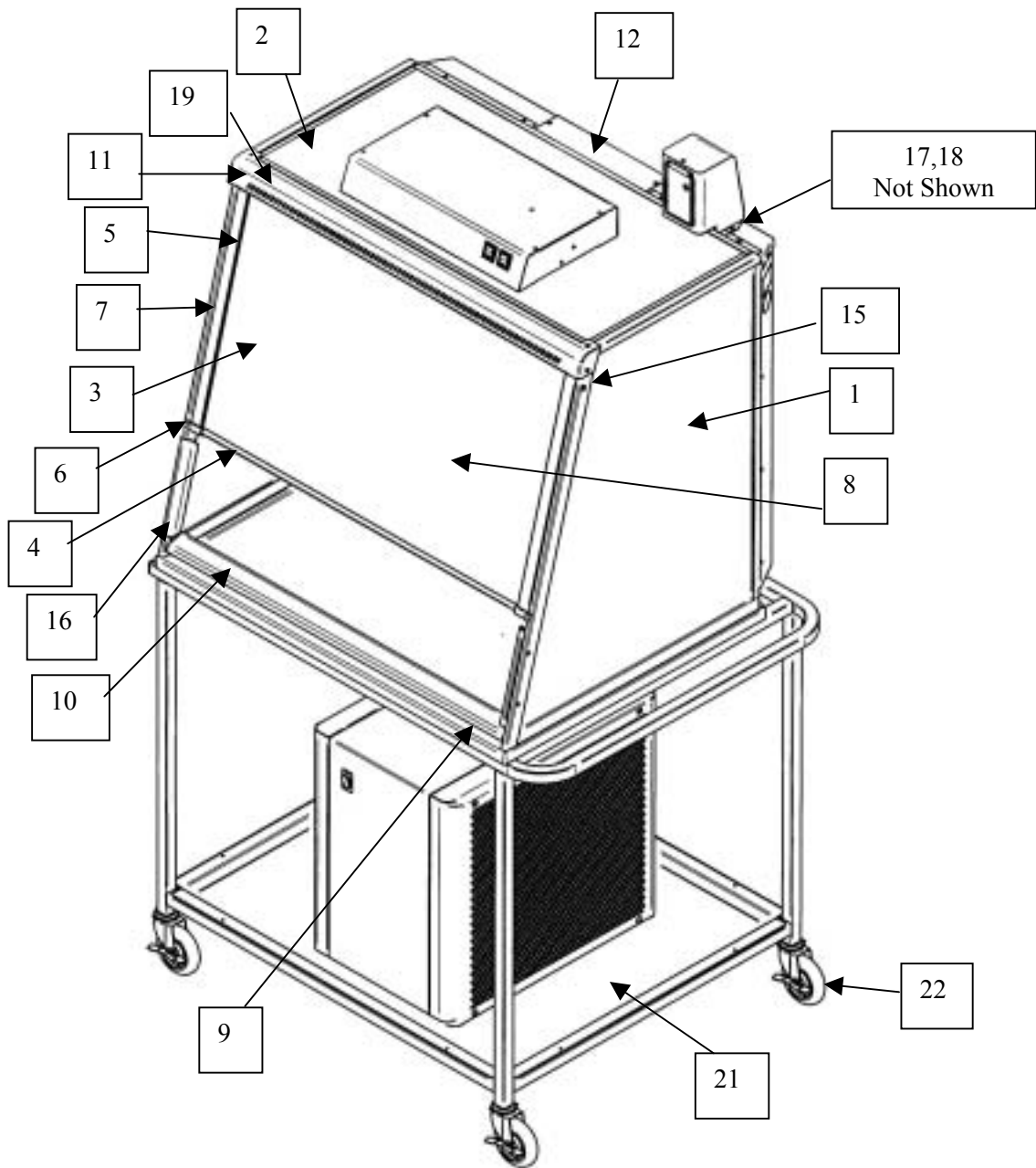

Figure A-1A

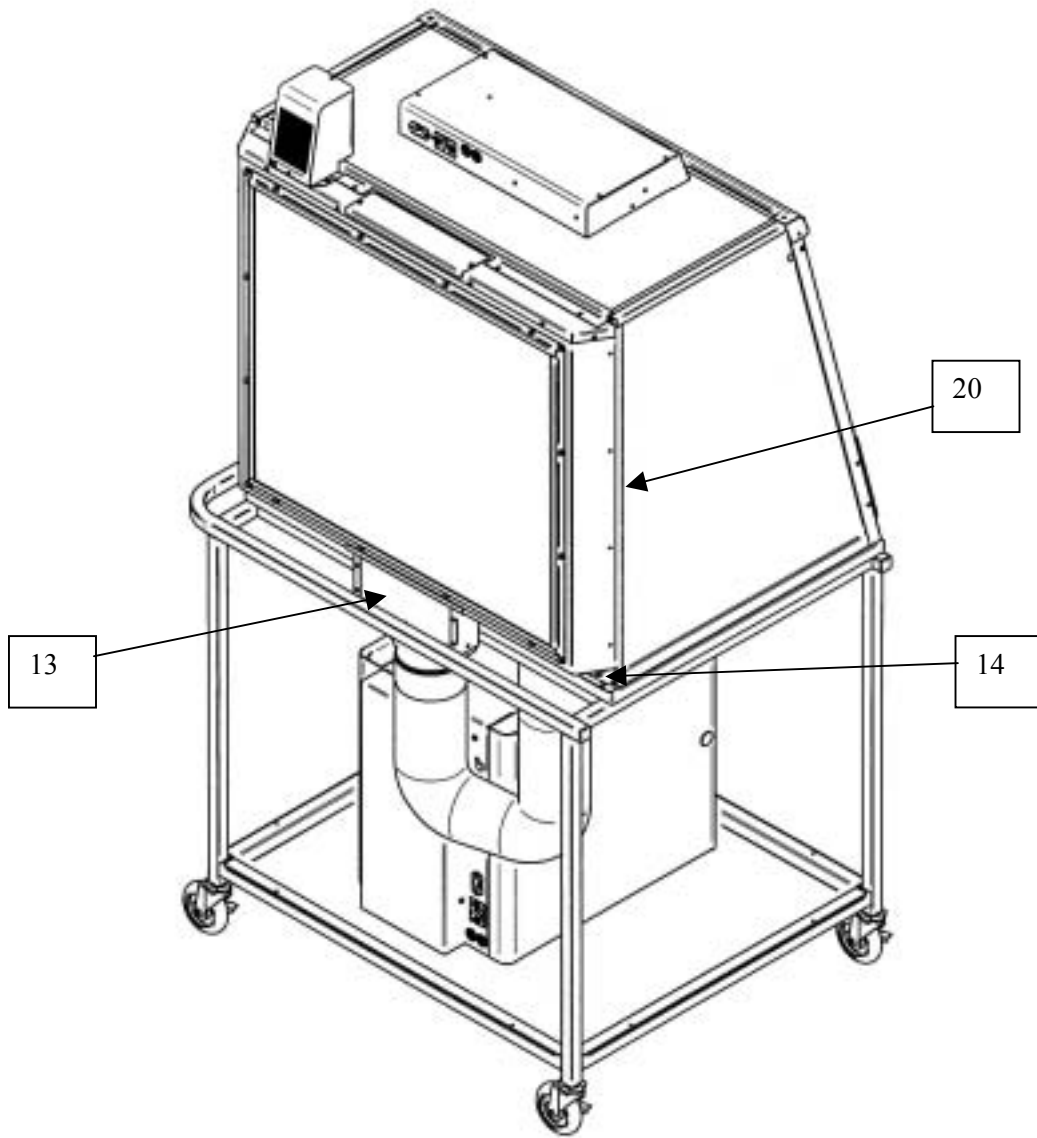

Figure A-1B

APPENDIX B

DIMENSIONS

See the following dimensions.

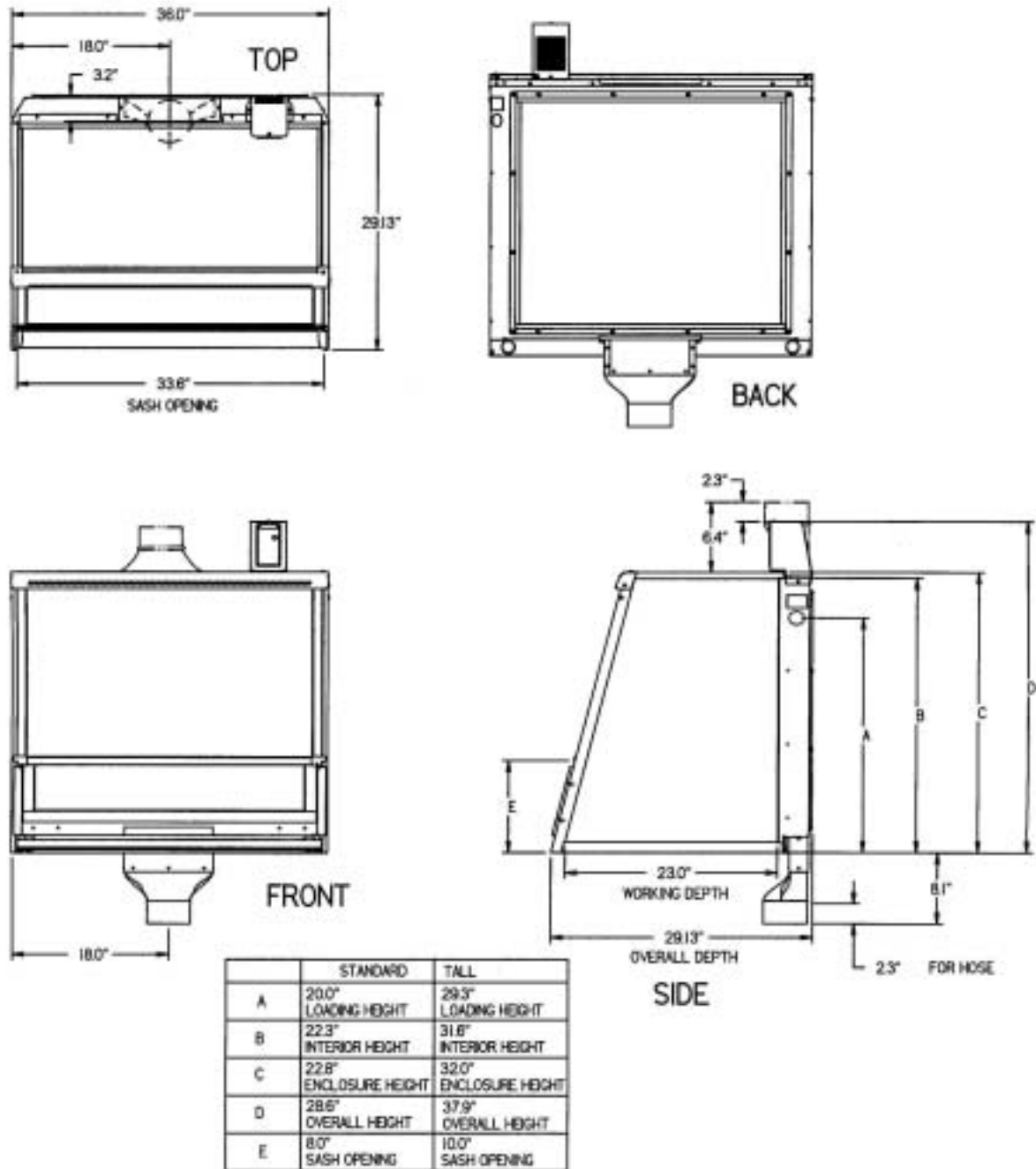

Figure B-1
Protector Demonstration Hood Dimensions

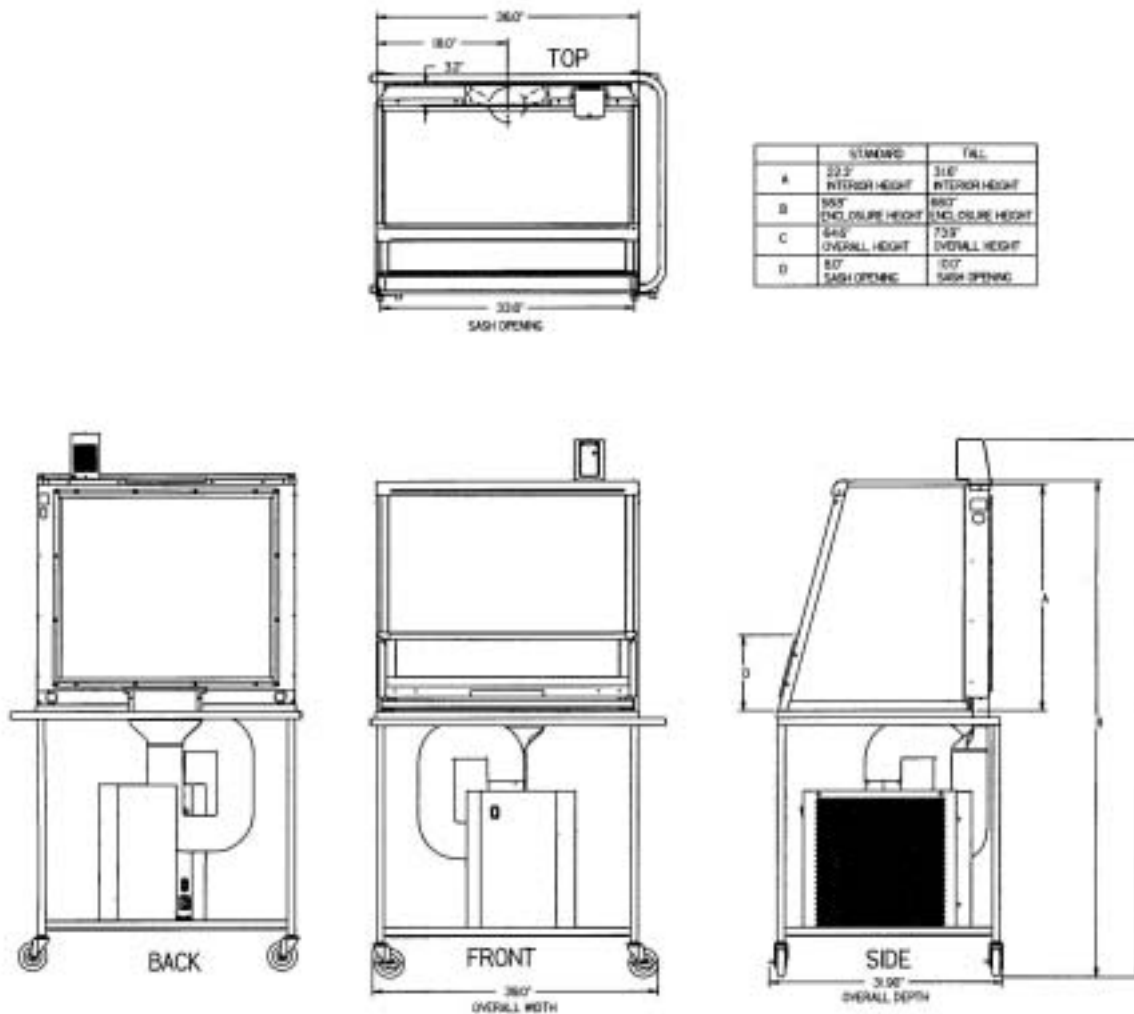

Figure B-2
Protector Mobile Demonstration Hood Dimensions

APPENDIX C

SPECIFICATIONS

Electrical Specifications

115V, 60 Hz Mobile Demonstration Hood, 10 Amps Max.
230V, 50/60 Hz Mobile Demonstration Hood, 5 Amps Max.

Environmental Conditions

- Indoor use only.
- Maximum altitude: 6562 feet (2000 meters).
- Ambient temperature range: 41° to 104°F (5° to 40°C).
- Maximum relative humidity: 80% for temperatures up to 88°F (31°C), decreasing linearly to 50% relative humidity at 104°F (40°C).
- Main supply voltage fluctuations not to exceed $\pm 10\%$ of the nominal voltage.
- Transient over-voltages according to Installation Categories II (Over-voltage Categories per IEC 1010). Temporary voltage spikes on the AC input line that may be as high as 1500V for 115V models and 2500V for 230V models are allowed.
- Used in an environment of Pollution degrees 2 (i.e., where normally only non-conductive atmospheres are present). Occasionally, however, a temporary conductivity caused by condensation must be expected, in accordance with IEC 664.

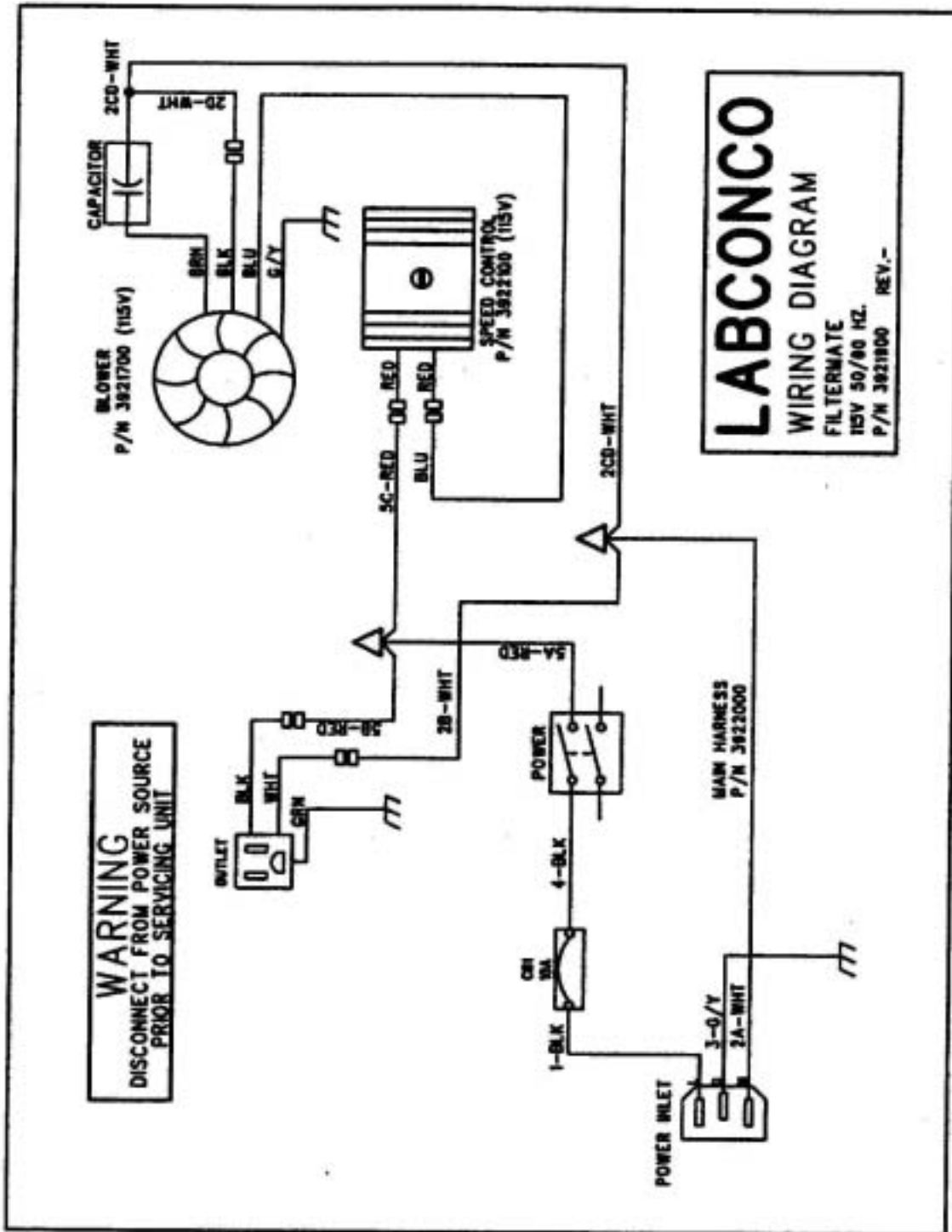

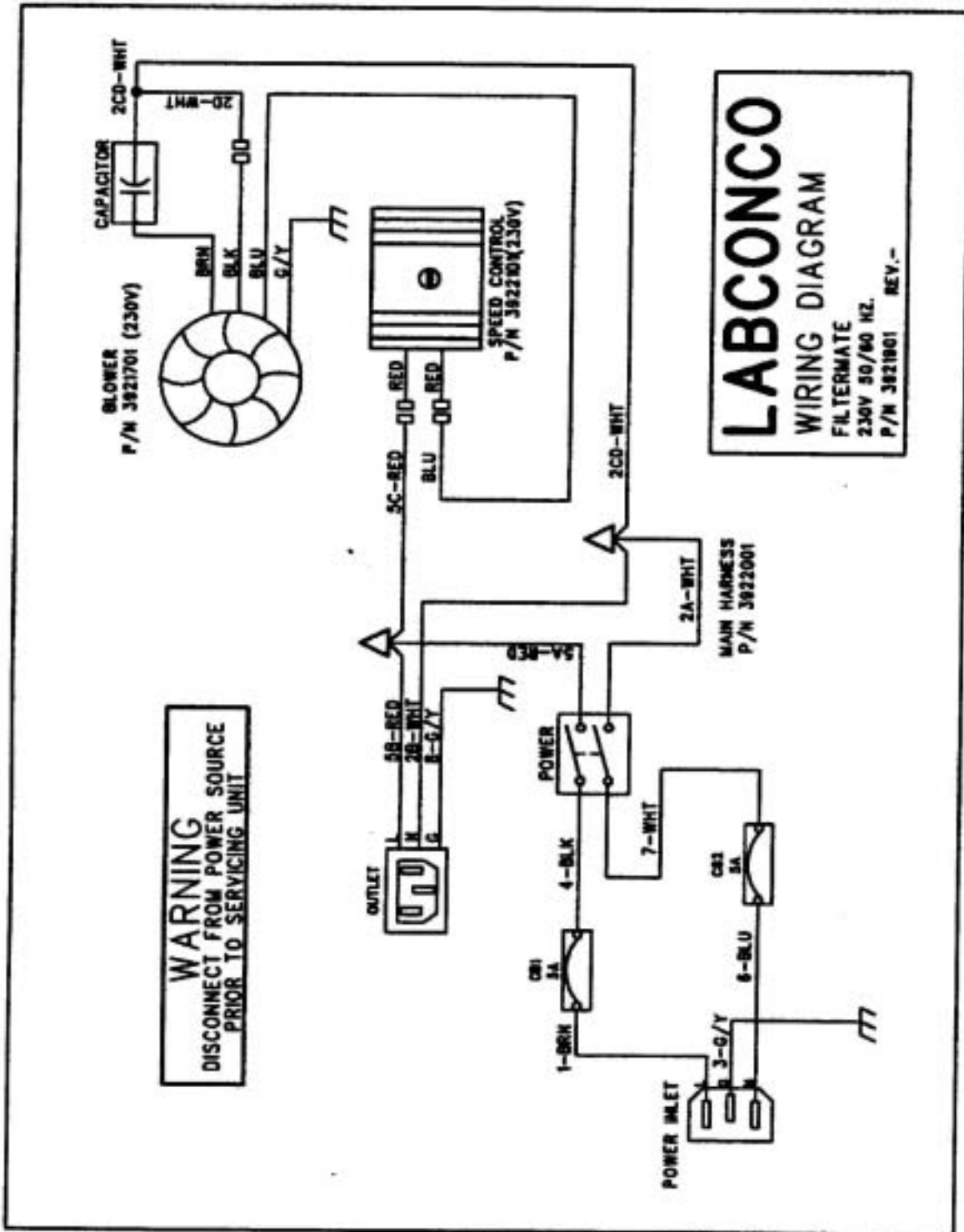

APPENDIX D

REFERENCES

Many excellent reference texts and booklets are currently available. The following is a brief listing:

Laboratory Ventilation Standards

Federal Register 29 CFR Part 1910

Non-mandatory recommendations from "Prudent Practices".

- Fume hoods should have a continuous monitoring device
- Face velocities should be between 60-100 linear feet per minute (lfpm)
- Average 2.5 linear feet of hood space per person

Occupational Health and Safety

U.S. Department of Labor

200 Constitution Avenue N.W.

Washington, DC 20210

(202) 523-1452

www.osha.gov

Industrial Ventilation-ACGIH

- Fume hood face velocities between 60-100 lfpm
- Maximum of 125 lfpm for radioisotope hoods
- Duct velocities of 1000-2000 fpm for vapors, gasses and smoke
- Stack discharge height 1.3-2.0 x building height
- Well designed fume hood containment loss, <0.10 ppm

Industrial Ventilation, A Manual of Recommended Practice.

24th Edition, 2001

American Conference of Governmental Industrial Hygienists

1330 Kemper Meadow drive

Cincinnati, OH 45240-1634

(513) 742-2020

www.acgih.org

ASHRAE 110-1995 Method of Testing Performance of Fume Hoods

Evaluates fume hood's containment characteristics

- Three part test: Smoke generation, Face velocity profile, Tracer gas release @ 4 liters per minute
- Rated As Manufactured (AM), As Installed (AI) and As Used (AU)

American Society of Heating, Refrigerating, and Air Conditioning Engineers

1791 Tullie Circle N.E.

Atlanta, GA 30329

(404) 636-8400

www.ashrae.org

ANSI Z9.5-1993 Laboratory Standard

Covers entire laboratory ventilation system.

- Vertical stack discharge @ 2000-3000 fpm
- New and remodeled hoods shall have a monitoring device
- Ductless hoods should only be used with non-hazardous materials
- Fume hood face velocities between 80 – 120 fpm

American Industrial Hygiene Association

2700 Prosperity Avenue, Suite 250

Fairfax, VA 22031

(703) 849-8888

www.aiha.org

SEFA 1-2002

- Fume hood face velocities based on toxicity levels of chemicals
 - Class A – 125 to 150 fpm
 - Class B – 80 to 100 fpm
 - Class C – 75 to 80 fpm
- Test method – face velocity profile and smoke generation

Scientific Equipment & Furniture Association

1028 Duchess Drive

McLean, VA 22102

(703) 538-6007

www.sefalabs.com

NFPA 45 – 2002 Fire Protection for Laboratories Using Chemicals

- Laboratory hoods should not be relied on for explosion protection
- Exhaust air from fume hoods should not be recirculated
- Services should be external to the hood
- Canopy hoods only for non-hazardous applications
- Materials of construction should have flame spread of 25 or less
- 80 to 120 fpm to prevent escape

NFPA 30 – 2000 Flammable and Combustible Liquids Code

- Approved cabinets may be metal or wood
- Vent location on cabinets are required
- Venting of cabinets not a requirement

National Fire Protection Association
1 Batterymarch Park
P.O. Box 9101
Quincy, MA 02269-9101
(800) 344-3555
www.nfpa.org

General References

American Conference of Governmental Industrial Hygienists. *Industrial Ventilation, A Manual of Recommended Practice*, Cincinnati, OH

ASHRAE Standard Committee. *ASHRAE Standard* Atlanta: ASHRAE Publications Sales Department, 1995

British Standards Institution, *Laboratory Fume Cupboards*. Parts 1, 2 and 3, London: 1990

Department of Labor, Occupational Safety and Health Administration, *29 CFR Part 1910, Occupational Exposures to Hazardous Chemicals in Laboratories, Final Rule*. Vol. 55, No. 21. Washington D.C.:1990

DiBerardinis. L. et al. *Guides for Laboratory Design, Health and Safety Considerations*. Wiley & Sons, 1987

McDermott, Henry, *Handbook of Ventilation for Contaminant Control*, 2nd Edition. Butterworth Publishers, 1985.

Miller, Brinton M. et al. *Laboratory Safety: Principles and Practices*. American Society for Microbiology, Washington, D.C.: 1986

NIH Guidelines for the Laboratory Use of Chemical Carcinogens. NIH Publication No. 81-2385.

Rayburn, Stephen R. *The Foundation of Laboratory Safety, A Guide for the Biomedical Laboratory*. Springer-Verlag, New York: 1990

Sax, N. Irving and Lewis, JR., Richard J. *Rapid Guide to Hazardous Chemicals in the Workplace*. Van Nostrand Reinhold, 1987.

Schilt, Alfred A. *Perchloric Acid and Perchlorates*. The G. Frederick Smith Chemical Company, Columbus, OH: 1979.

Steere, Norman. *CRC Handbook of Laboratory Safety*, 2nd Edition. CRC Press, 1971.

DECLARATION OF CONFORMITY

Application Council Directive(s): 73/23/EEC, 89/336/EEC

Standard(s) to which conformity is declared: EN61010, EN55022, EN50082-1

Manufacturer's Name: Labconco Corporation

Manufacturer's Address: 8811 Prospect Avenue
Kansas City, MO 64132 USA

Importer's Name: See Shipping/Customs Documents*

Importer's Address: See Shipping/Customs Documents for your equipment

Type of Equipment: Laboratory Equipment Protector Demonstration Hoods

3944300 Series 3' Demonstration Hoods
3945000 Series 3' Mobile Demonstration Hoods

Serial No.: Various – See Individual Declaration

Year of Manufacture: 2004 and subsequent

I, the undersigned, hereby declare that the equipment specified above conforms to the above Directive(s) and Standard(s).

See individual Declaration of Conformity which will be signed by the importer for your country.

Place: _____
(Signature)

Date: _____
(Full Name)

(Position)

*An individual version of this declaration is included with your shipping/customs documentation.

For more information, please contact us:

ExpotechUSA

10700 Rockley Road
Houston, Texas 77099
USA

281-496-0900 [voice]

281-496-0400 [fax]

E-mail: sales@expotechusa.com

Website: www.ExpotechUSA.com